

# IRS01

## Технические характеристики

### По вопросам продаж и поддержки обращайтесь:

Алматы (7273)495-231	Казань (843)206-01-48	Новокузнецк (3843)20-46-81	Смоленск (4812)29-41-54
Архангельск (8182)63-90-72	Калининград (4012)72-03-81	Новосибирск (383)227-86-73	Сочи (862)225-72-31
Астрахань (8512)99-46-04	Калуга (4842)92-23-67	Омск (3812)21-46-40	Ставрополь (8652)20-65-13
Барнаул (3852)73-04-60	Кемерово (3842)65-04-62	Орел (4862)44-53-42	Сургут (3462)77-98-35
Белгород (4722)40-23-64	Киров (8332)68-02-04	Оренбург (3532)37-68-04	Тверь (4822)63-31-35
Брянск (4832)59-03-52	Краснодар (861)203-40-90	Пенза (8412)22-31-16	Томск (3822)98-41-53
Владивосток (423)249-28-31	Красноярск (391)204-63-61	Пермь (342)205-81-47	Тула (4872)74-02-29
Волгоград (844)278-03-48	Курск (4712)77-13-04	Ростов-на-Дону (863)308-18-15	Тюмень (3452)66-21-18
Вологда (8172)26-41-59	Липецк (4742)52-20-81	Рязань (4912)46-61-64	Ульяновск (8422)24-23-59
Воронеж (473)204-51-73	Магнитогорск (3519)55-03-13	Самара (846)206-03-16	Уфа (347)229-48-12
Екатеринбург (343)384-55-89	Москва (495)268-04-70	Санкт-Петербург (812)309-46-40	Хабаровск (4212)92-98-04
Иваново (4932)77-34-06	Мурманск (8152)59-64-93	Саратов (845)249-38-78	Челябинск (351)202-03-61
Ижевск (3412)26-03-58	Набережные Челны (8552)20-53-41	Севастополь (8692)22-31-93	Череповец (8202)49-02-64
Иркутск (395)279-98-46	Нижний Новгород (831)429-08-12	Симферополь (3652)67-13-56	Ярославль (4852)69-52-93
Россия (495)268-04-70	Киргизия (996)312-96-26-47	Казахстан (7172)727-132	

# Long Range Motion Radar Sensor IRS01

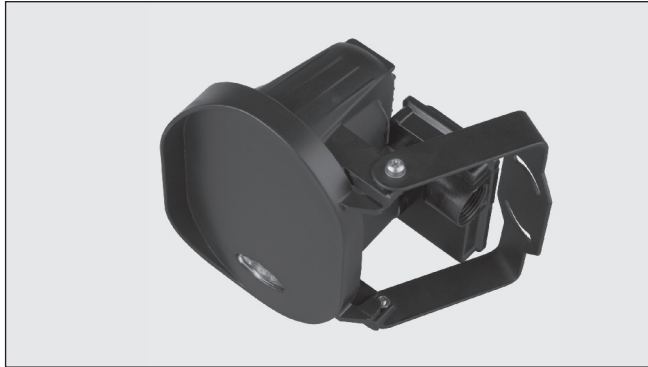

- Vehicle and person detection
- Long range of detection
- In field adjustment of the area detection with remote control
- Low power consumption
- Sealed against dust and humidity
- 7m maximum height
- CE0682, FCC, UR, UL325



## Product Description

IRS Long range sensor is a digital unidirectional motion sensor for trouble-free opening of all types of industrial automatic doors. It can be adapted to every application without further accessories and can be controlled by an infrared remote control-

ler. Mounting height up to 7m (23ft) to detect vehicle or person motion towards or away from the sensor. Like most of other microwave detectors equipped with planar flat antenna, the sensor works on echo doppler signal for detecting movements.

## Ordering Key

**IRS 01**

Type \_\_\_\_\_  
Detection mode \_\_\_\_\_

## General Data

<b>Sensing field orientation</b>	By housing orientation
<b>Detection angle</b>	±45° vertical and lateral
<b>Detecting area</b>	see the "Maximum Field Extension" pictures
<b>Detection mode</b>	
Unidirectional	to detect motions towards or away from sensor
Bidirectional	to detect motions towards <b>and</b> away from sensor
<b>Motion detecting speed</b>	0.05 - 3.0m/s (0.164 - 6.56fps) along sensor axis
<b>Frequency emitted</b>	(K-Band) 24.125GHz
<b>Approvals</b>	CE0682, FCC, UR and UL325

## Electrical Data

<b>Radiated power</b>	<16dBm EIRP
<b>Rated supply voltage</b>	12 - 24VAC ±10% 12 - 32VDC
<b>Main frequency</b>	50 to 60HZ
<b>Power consumption</b>	<1.2W
<b>Output Relay</b>	2 x SPDT
<b>Rated Voltage</b>	30VAC/DC
Max switching current	1A (resistive load)
Max switching power	30W (resistive load) Powered by Class 2 or LVE transformer
<b>Hold time</b>	0.5 - 6s (adjustable)

## Environmental Data

<b>Temperature range</b>	-20°C to +60°C (-4°F to +140°F)
<b>Humidity</b>	from 0% to 90%RH
<b>Immunity</b>	R&TTE 1999/5/EC EMC 2004/108/EEC
<b>Max. mounting height</b>	2.5m to 7m (8.20 to 22.96ft)
<b>Degree of protection</b>	IP65, NEMA - 4

## Mechanical Data

<b>Housing Material</b>	Aluminium with plastic junction box
<b>Dimensions WxHxD</b>	137 x 188 x 91.5mm (5.39 x 7.40 x 3.6inch.)
<b>Weight</b>	300g (10.58oz)
<b>Cable length</b>	5m (16.4ft)
<b>Colour</b>	Black



## Adjustments and Settings

<b>Manual adjustment</b>	<ul style="list-style-type: none"> <li>orientation of sensing field (mechanically)</li> <li>multiple functions (by push buttons on board inside).</li> </ul>	<b>Immunity detection</b>	<ul style="list-style-type: none"> <li>Normal mode</li> <li>Immunity</li> <li>“Quasi-presence”</li> <li>Lateral Traffic suppression</li> </ul>
<b>Remote control adjustments</b>	<ul style="list-style-type: none"> <li>Sensitivity</li> <li>Hold time</li> <li>Mounting height</li> <li>Detection mode</li> <li>Immunity</li> <li>Relay configuration</li> </ul>	<b>R1 and R2 Relay status</b>	<ul style="list-style-type: none"> <li>Active, Passive, can be set independently by remote controller;</li> <li>Switching in automatic mode (normal detection) the last status of relays will be considered as steady state condition.</li> </ul>
<b>Sensitivity</b>	<ul style="list-style-type: none"> <li>5 levels. It allows increment or decrement of detection field.</li> </ul>	<b>Security code</b>	<ul style="list-style-type: none"> <li>4-digit PIN access code to lock or unlock the keyboard of controller.</li> </ul>
<b>R1 and R2 Relay hold time</b>	<ul style="list-style-type: none"> <li>5 levels (0.5 to 6s).</li> </ul>		
<b>Unidirectional mode</b>	<ul style="list-style-type: none"> <li>Forward or backward.</li> </ul>		

## Switching ON and factory settings

- After the supply voltage has been connected, the RED LED will start flashing quickly for 3 seconds. The unit is set up in factory at the following default values:
 

A) Sensitivity:	level 1 (SENS+1)
B) Mounting height:	2.5 to 3.5 m (F1)
C) Relay hold time:	0.5 sec (HT+1)
D) Operating mode	V or P
E) Detection Recognition	movements towards the detector (FW)
F) Immunity, Quasi-presence, and Lateral Traffic Suppression:	OFF
G) R1 and R2 Relay Status:	OFF in rest condition
H) PIN security:	0000 - lock keyboard disabled on remote controller
- Set mounting height (F1...F4) if different from factory setting. The detector will not function correctly if the wrong mounting height is set
- Set field size (SEN+1...5) and if necessary using inclination angle, 15-45°.
- Set the optional volume of Relay Hold time (HT +1...5) if different from factory setting HT+1 (0.5")
- Set the other parameters as the specific application requires.

## Electrical Connection

The unit should be powered by Class 2 or LVE transformer. Do not switch on the power until all primary and secondary wiring are completed. The contacts of relays should be connected to Class 2 circuit. Opening the junction box of the housing an 8 pole snap connector will be accessible. Connect the wires as below indicated.

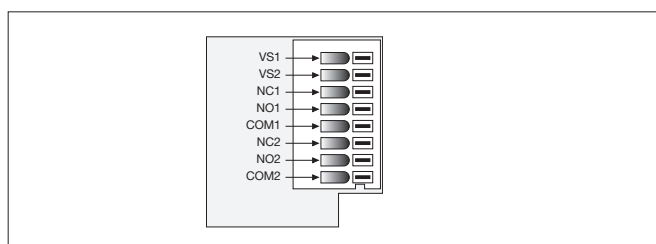

Code	Description
VS1	First supply terminal
VS2	Second supply terminal
NC1	Relay n°1 - Normally close contact
NO1	Relay n°1 - Normally open contact
COM1	Relay n°1 - Common
NC2	Relay n°2 - Normally close contact
NO2	Relay n°2 - Normally open contact
COM2	Relay n°2 - Common

### Inside View

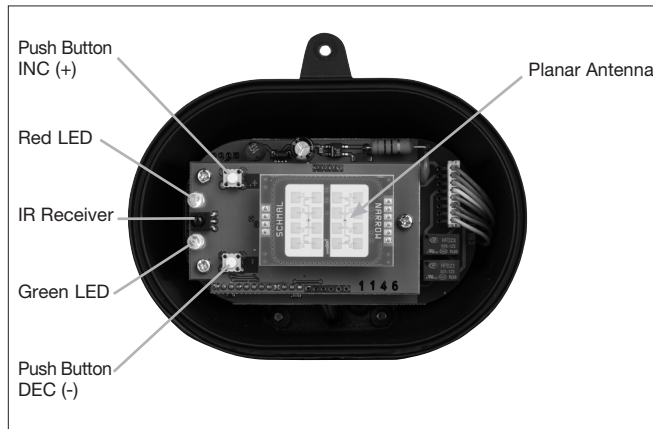

### Mounting Instructions

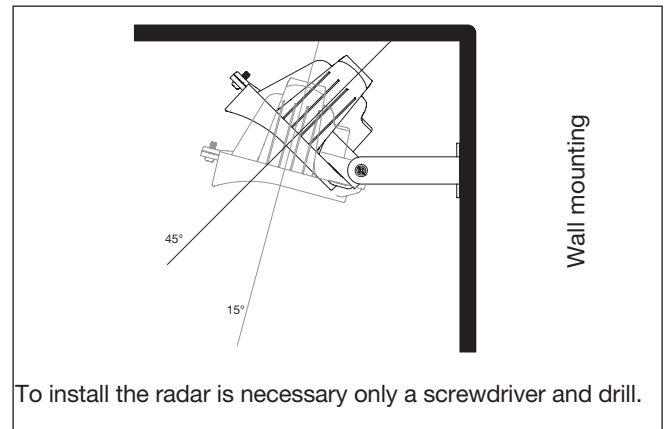

### Sensing Field adjustment

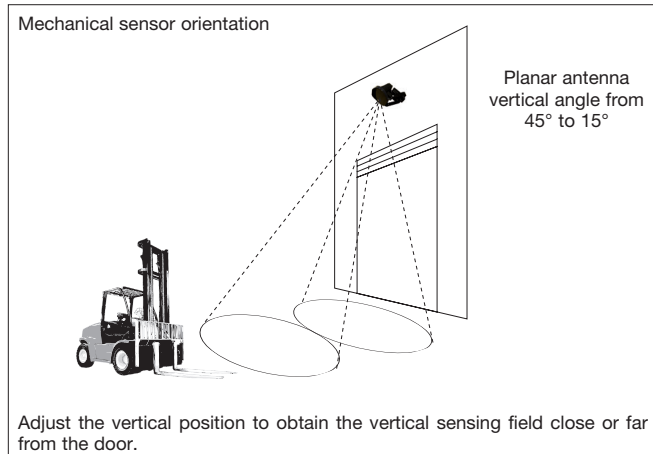

### Sensing field adjustment according to Sensitivity setting and mounting Height

The sensing field area size (lobo) depends on the sensitivity parameter setting and the radar mounting height.

### Maximum field extension (with level 5 as sensitivity)

Mounting height: 4.5m with 3 different inclination angles.

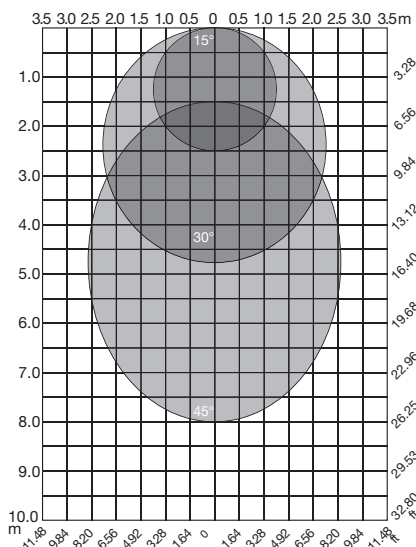

Mounting height: 7m with 3 different inclination angles.

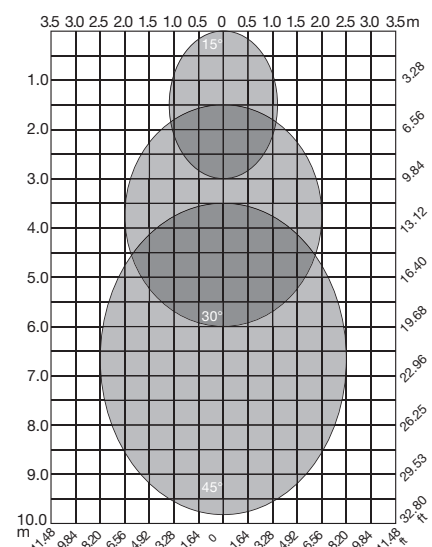

## Installation Tips

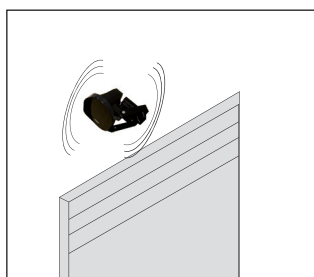

The sensor shall be firmly fixed to avoid any false activation by shocks or vibrations. It should not be mounted to high vibration surfaces such as a door canopy that houses the operating mechanism.

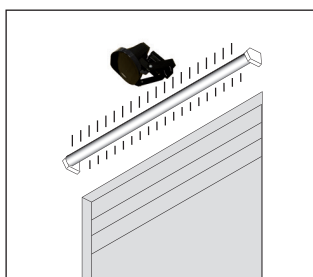

Do not install the radar close to fluorescent lamps.

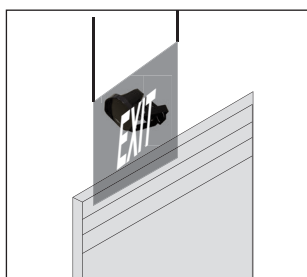

Sensor should not be placed near metal halide lights or placed behind any kind of protection layer or plate.

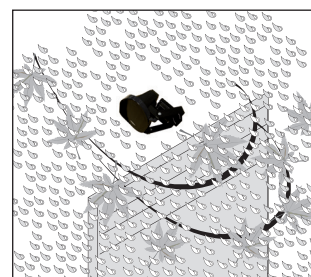

The housing of the sensor is concealed within a NEMA-4 type-rated enclosures and is extremely reliable in harsh environments.



## Signalling by LED

- The RED and GREEN LED flash in the following conditions:
- When power is turned ON, the RED LED flashes for 3 seconds.
- During a object detection the GREEN or RED LED lights ON (depending by operating mode setting).
- During programming procedure by remote controller the RED LED flashes many times as the function being modified (see following table). A blind time of 5 seconds will be inserted during the signalling.
- During manual programming procedure the RED and GREEN LED flash a number of time corresponding to the step of the procedure (see description of the procedure).

## Relay vs Function

Relay #	IR Remote controller button	Function	LED	Direction	Connection pin
1	R1	Vehicles	RED	Forward (also Backward & Bidirection in PR operating mode)	COM - pin5
					NO - pin4
					NC - pin3
2	R2	Persons	GREEN	Backward (also Forward & Bidirection in VR operating mode)	COM - pin8
					NO - pin7
					NC - pin6

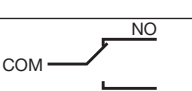
## Relay configuration at NO DETECTION

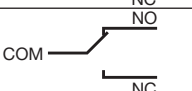
	LED OFF	LED ON
R1 / Red LED		
R2 / Green LED		

## Dimensions mm (inches)

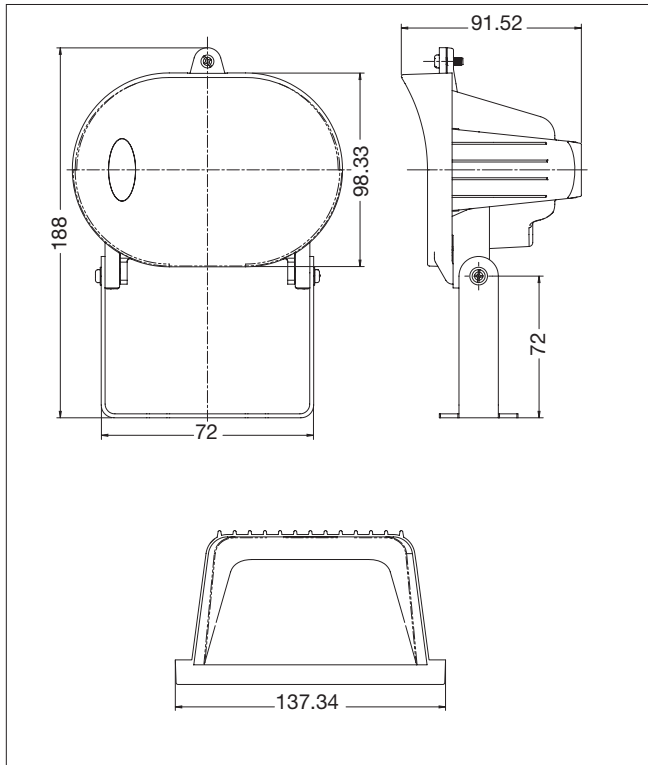

## Accessory

### Ordering Key

**IRS 00 RC**

Type  
IR remote controller

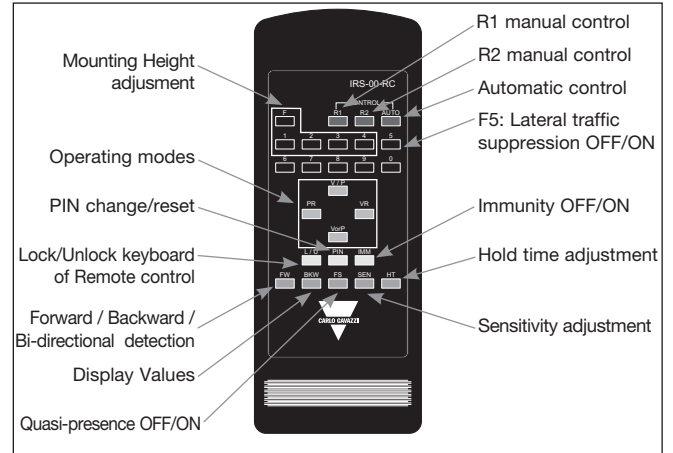

**Note:** For optimum results point the remote control at the sensor before pressing its buttons.

**Note:** before using the remote controller

- open the battery compartment at the back of the remote control;
- insert two AAA batteries supplied with the remote control;
- close the batteries compartment.

**По вопросам продаж и поддержки обращайтесь:**

Алматы (7273)495-231	Казань (843)206-01-48	Новокузнецк (3843)20-46-81	Смоленск (4812)29-41-54
Архангельск (8182)63-90-72	Калининград (4012)72-03-81	Новосибирск (383)227-86-73	Сочи (862)225-72-31
Астрахань (8512)99-46-04	Калуга (4842)92-23-67	Омск (3812)21-46-40	Ставрополь (8652)20-65-13
Барнаул (3852)73-04-60	Кемерово (3842)65-04-62	Орел (4862)44-53-42	Сургут (3462)77-98-35
Белгород (4722)40-23-64	Киров (8332)68-02-04	Оренбург (3532)37-68-04	Тверь (4822)63-31-35
Брянск (4832)59-03-52	Краснодар (861)203-40-90	Пенза (8412)22-31-16	Томск (3822)98-41-53
Владивосток (423)249-28-31	Красноярск (391)204-63-61	Пермь (342)205-81-47	Тула (4872)74-02-29
Волгоград (844)278-03-48	Курск (4712)77-13-04	Ростов-на-Дону (863)308-18-15	Тюмень (3452)66-21-18
Вологда (8172)26-41-59	Липецк (4742)52-20-81	Рязань (4912)46-61-64	Ульяновск (8422)24-23-59
Воронеж (473)204-51-73	Магнитогорск (3519)55-03-13	Самара (846)206-03-16	Уфа (347)229-48-12
Екатеринбург (343)384-55-89	Москва (495)268-04-70	Санкт-Петербург (812)309-46-40	Хабаровск (4212)92-98-04
Иваново (4932)77-34-06	Мурманск (8152)59-64-93	Саратов (845)249-38-78	Челябинск (351)202-03-61
Ижевск (3412)26-03-58	Набережные Челны (8552)20-53-41	Севастополь (8692)22-31-93	Череповец (8202)49-02-64
Иркутск (395)279-98-46	Нижний Новгород (831)429-08-12	Симферополь (3652)67-13-56	Ярославль (4852)69-52-93
Россия (495)268-04-70	Киргизия (996)312-96-26-47	Казахстан (7172)727-132	