

PMD

Технические характеристики

По вопросам продаж и поддержки обращайтесь:

Алматы (7273)495-231	Казань (843)206-01-48	Новокузнецк (3843)20-46-81	Смоленск (4812)29-41-54
Архангельск (8182)63-90-72	Калининград (4012)72-03-81	Новосибирск (383)227-86-73	Сочи (862)225-72-31
Астрахань (8512)99-46-04	Калуга (4842)92-23-67	Омск (3812)21-46-40	Ставрополь (8652)20-65-13
Барнаул (3852)73-04-60	Кемерово (3842)65-04-62	Орел (4862)44-53-42	Сургут (3462)77-98-35
Белгород (4722)40-23-64	Киров (8332)68-02-04	Оренбург (3532)37-68-04	Тверь (4822)63-31-35
Брянск (4832)59-03-52	Краснодар (861)203-40-90	Пенза (8412)22-31-16	Томск (3822)98-41-53
Владивосток (423)249-28-31	Красноярск (391)204-63-61	Пермь (342)205-81-47	Тула (4872)74-02-29
Волгоград (844)278-03-48	Курск (4712)77-13-04	Ростов-на-Дону (863)308-18-15	Тюмень (3452)66-21-18
Вологда (8172)26-41-59	Липецк (4742)52-20-81	Рязань (4912)46-61-64	Ульяновск (8422)24-23-59
Воронеж (473)204-51-73	Магнитогорск (3519)55-03-13	Самара (846)206-03-16	Уфа (347)229-48-12
Екатеринбург (343)384-55-89	Москва (495)268-04-70	Санкт-Петербург (812)309-46-40	Хабаровск (4212)92-98-04
Иваново (4932)77-34-06	Мурманск (8152)59-64-93	Саратов (845)249-38-78	Челябинск (351)202-03-61
Ижевск (3412)26-03-58	Набережные Челны (8552)20-53-41	Севастополь (8692)22-31-93	Череповец (8202)49-02-64
Иркутск (395)279-98-46	Нижний Новгород (831)429-08-12	Симферополь (3652)67-13-56	Ярославль (4852)69-52-93
Россия (495)268-04-70	Киргизия (996)312-96-26-47	Казахстан (7172)727-132	

Photoelectrics

Diffuse-reflective, Transistor Output

Type PMD

CARLO GAVAZZI



- Range: 800 mm
- Modulated, infrared light
- Rated operational voltage: 10 to 40 VDC
- Output: 200 mA, NPN or PNP
- Make or break switching function (switch selectable)
- LED-indication for target detected
- 25 x 65 x 81 mm reinforced ABS housing, IP 67
- Timer options (adjustable)
- NO and NC output



Product Description

Diffuse-reflective photoelectric switch. Range up to 800 mm. Adjustable sensitivity. Immune to ambient light. Output function switch selectable. Protection degree IP 67. Screw terminal connection.

25 x 65 x 81 mm plastic housing. PG 13.5 or 1/2" NPT cable gland. Timer options: Delay on operate, delay on release, one shot (triggered on leading or trailing edge).

Ordering Key

PMD 8 P G T

Type _____
 Range _____
 Output _____
 Cable gland type _____
 Timing function _____

Type Selection

Housing W x H x D	Range S _n	Ordering no. without timer NPN	Ordering no. without timer PNP	Ordering no. with timer NPN	Ordering no. with timer PNP
25 x 65 x 81 PG 13.5 cable gland 1/2" NPT cable gland	800 mm 800 mm	PMD 8N G PMD 8N I	PMD 8P G PMD 8P I	PMD 8N GT PMD 8N IT	PMD 8P GT PMD 8P IT

Specifications

Rated operating distance (S_n) (0 to 5000 lux)	0.8 m, reference target Kodak test card R 27, white, 90% reflectivity, 200 x 200 mm	Response time OFF-ON (t _{ON}) ON-OFF (t _{OFF})	≤ 4 ms ≤ 6 ms
Rated operational volt. (U_B)	10 to 40 VDC	Time delay before avail. (t_v)	≤ 300 ms (typ. 100 ms)
Ripple (U_{rpp})	10%	Output function	switch selectable, make or break switching
Output current Continuous (I _a) Short-time (I)	≤ 200 mA 200 mA, max. load capacity 100 nF	Indication Target detected	LED, yellow
No load supply current (I_o)	≤ 40 mA	Optional timer Delay on operate Delay on release One shot	0.1 to 7 s ± 2 s 0.1 to 7 s ± 2 s 0.1 to 7 s ± 2 s
OFF-state current (I_r)	Max. 100 μA	Environment Installation category	III (IEC 60664/60664A; 60947-1)
Voltage drop (U_d)	≤ 2.5 VDC	Pollution degree	3 (IEC 60664/60664A; 60947-1)
Transient voltage	IEC 947-5-2, level 3, 2.5 kV	Degree of protection	IP 67 (IEC 60529; 60947-1)
Dielectric voltage	2000 VAC rms (cont./supply)	Temperature Operating Storage	-25° to +55°C (-13° to +131°F) -30° to +80°C (-22° to +176°F)
Sensing range (S_d)	0.2 - 0.8 m	CE-marking	Yes
Light source Light type Detection angle (200 x 200 mm test card)	GaAlAs, LED, 880 nm infrared, modulated		
Operating frequency	±12° 100 Hz		

Specifications (cont.)

Vibration	10 to 150 Hz, 0.5 mm/7.5 g (IEC 60068-2-6)
Shock	2 x 1 m & 100 x 0.5 m (IEC 60068-2-32)
Rated insulation voltage	50 VAC (rms)
Housing material	
Body	ABS, grey, reinforced
Front	SAN, black
Cover	PC, black
Cable gland	PA, black, reinforced
Mounting bracket	Steel, black
Connection	
Screw terminal	5 x 2 x 1 mm ²
Cable gland	PG 13.5 or 1/2" NPT for cable 6 to 10 mm
Weight	90 g

Connection Diagram

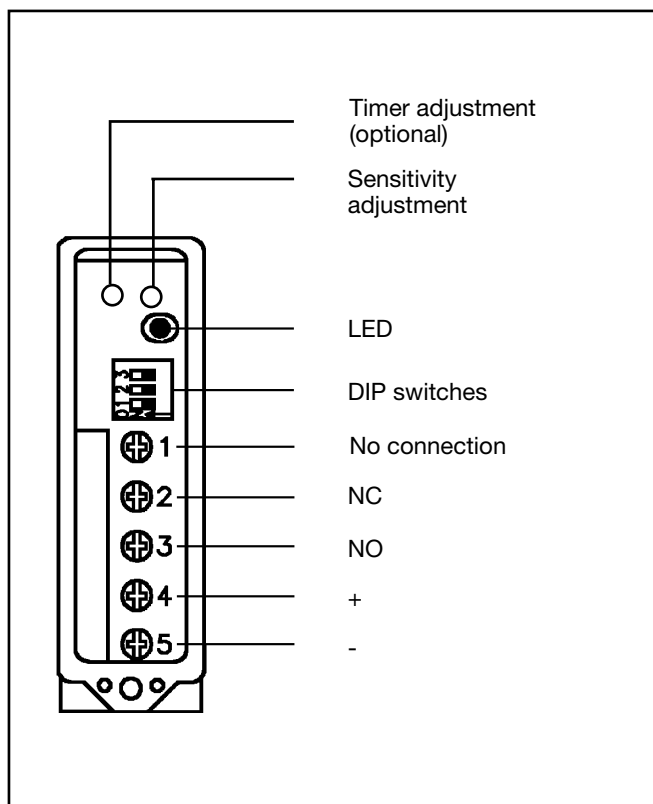

Truth Table

	Make switching		Break switching	
	No	Yes	No	Yes
Object present	No	Yes	No	Yes
LED	OFF	ON	OFF	ON
Load	Non-active	Active	Active	Non-active

Selection of Function

	Switch 1 2 3	
PMD 8 ..		1 Break switching
		2 Make switching
PMD 8 .. T		3 Delay on operate - Break switching
		4 Delay on operate - Make switching
		5 Delay on release - Break switching
		6 Delay on release - Make switching
		7 One shot, trailing edge - Break switching
		8 One shot, trailing edge - Make switching
		9 One shot, leading edge - Break switching
		10 One shot, leading edge - Make switching
		☒ Don't care
		Upper position ON (Mode 1) Lower position OFF (Mode 0)

Reduction Factors

Reduction factors photoelectric switches	
Note: Real sensing distance = rated operating distance (S _n) x reduction factor	
Kodak test card, white, type R 27, 90% reflectivity	1.0
Dead black cardboard	0.1 - 0.4
Kodak test card, grey, type R 27	0.41 - 0.45
White Styropack	1.0 - 1.2
Bright metal	1.2 - 2.0
White cotton	0.5 - 0.8
Grey PVC	0.4 - 0.8
Raw wood	0.4 - 0.8
ER 1, reflector	0.3

Delivery Contents

- Photoelectric switch: PMD
- Cable gland
- Installation instruction
- Mounting bracket
- **Packaging:** Corrugated cardboard
(environmentally friendly recycling material)

Operation Diagram

t = Time delay
tv = Power ON delay

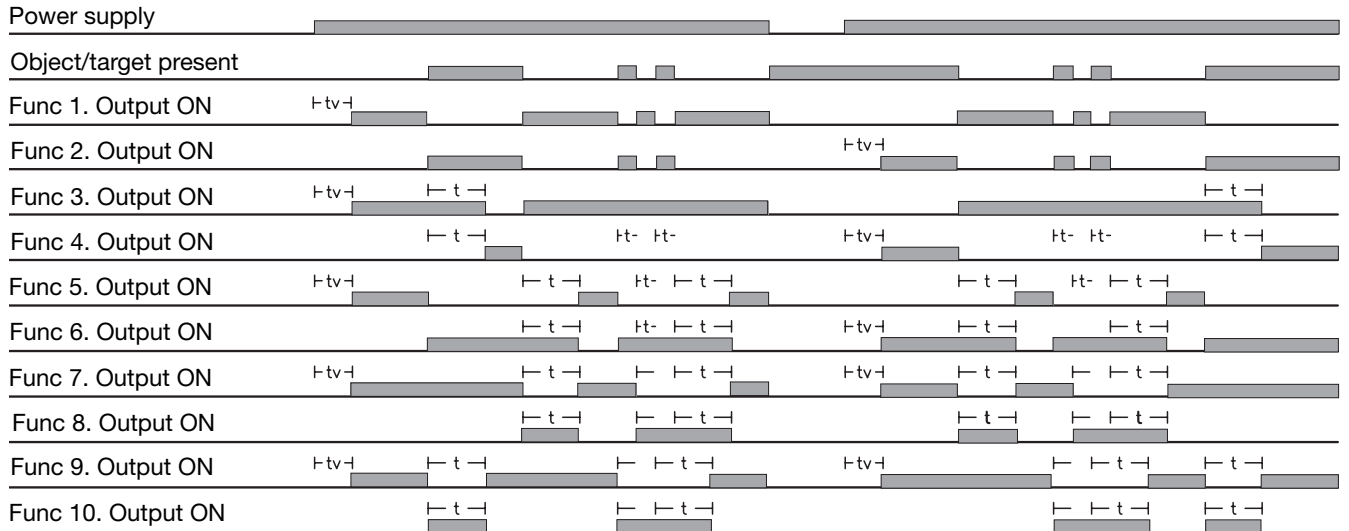

Dimensions

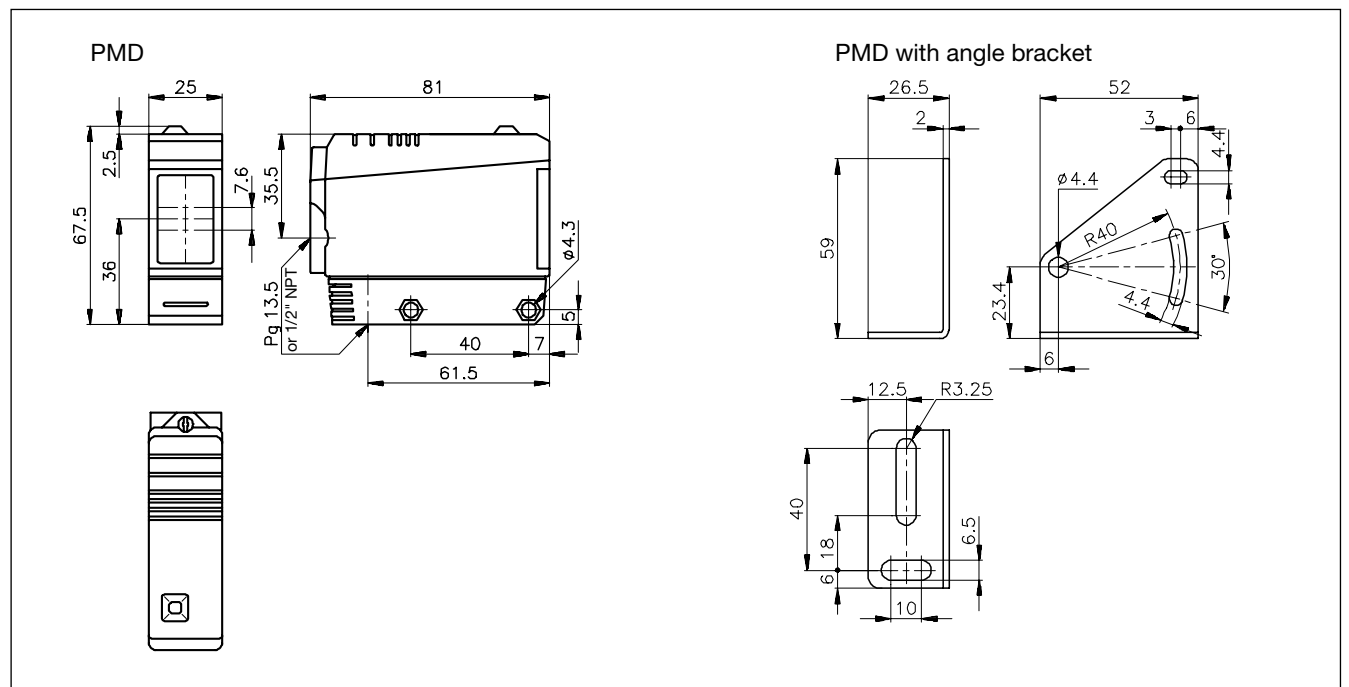

Photoelectrics

Diffuse-reflective, Relay Output

Type PMD

CARLO GAVAZZI



- Range: 800 mm
- Modulated, infrared light
- Make or break switching function (switch selectable)
- LED-indication for target detected
- Multi supply voltage:
12 to 240 VDC and
24 to 240 VAC, 50/60 Hz
- 25 x 65 x 81 mm reinforced PC housing, IP 67
- Timer options (adjustable)
- NO and NC output



Product Description

Diffuse-reflective photoelectric switch. Range up to 0.8 m. Adjustable sensitivity. Immune to ambient light. Output function switch selectable. Protection degree IP 67. Screw terminal connec-

tion. 25 x 65 x 81 mm plastic housing. PG 13 or 1/2" NPT cable gland. Timer options: Delay on operate, delay on release, one shot (triggered on leading or trailing edge).

Ordering Key

PMD8R G T

Type _____
Cable gland _____
Option: Timer function _____

Type Selection

Housing W x H x D	Ordering no. without timer	Ordering no. with timer
25 x 65 x 81 PG 13.5 cable gland 1/2" NPT cable gland	PMD 8R G PMD 8R I	PMD 8R GT PMD 8R IT

Specifications

Rated operating dist. (S_n) (0 to 5,000 lux)	800 mm Reference target: Kodak test card R27, white, 90% reflectivity, 200 x 200 mm	Optical angle (200 x 200 mm test card)	$\pm 12^\circ$
Rated operational volt. (U_b) AC: 45 to 65 Hz	10.8 to 264 VDC 21.6 to 264 VAC	Operating frequency	20 Hz
Rated operational power (relay ON)	≤ 2 W (2.5 VA)	Response time OFF-ON (t_{ON}) ON-OFF (t_{OFF})	≤ 20 ms ≤ 30 ms
Output Contact ratings (AgCdO) Resistive loads AC 1 DC 1 Small inductive loads AC 15 DC 13 Mechanical life (typical) Electrical life (typical)	μ (micro gap) 3 A/250 VAC 3 A/30 VDC 2 A/250 VAC 3 A/30 VDC $\geq 40 \times 10^6$ operations $\geq 5 \times 10^5$ operations at 220 VAC - 3 A resistive load: 360 impulses/h	Power ON delay (t_v)	≤ 300 ms (typ. 100 ms)
Dielectric voltage	2000 VAC (rms) (cont./supply)	Output function	Switch selectable, make or break switching
Sensing range (S_d)	0.2 - 0.8 m	Indication Target detected	LED, yellow
Light source	GaAlAs, LED, 880 nm	Optional timer Delay on operate Delay on release One shot	0.1 to 7 s ± 2 s 0.1 to 7 s ± 2 s 0.1 to 7 s ± 2 s
Light type	Infrared, modulated	Environment Overvoltage category Pollution degree Degree of protection	III (IEC 60664/60664A; 60947-1) 3 (IEC 60664/60664A; 60947-1) IP 67 (IEC 60529; 60947-1)
		Temperature Operating Storage	-25° to +55°C (-13° to +131°F) -30° to +80°C (-22° to +176°F)

Specifications (cont.)

Vibration	10 to 150 Hz, 0.5 mm/7.5 g (IEC 60068-2-6)
Shock	2 x 1 m & 100 x 0.5 m (IEC 60068-2-32)
Rated insulation voltage	250 VAC (rms)
Housing material	
Body	PC/ABS, grey, reinforced
Front	PC, black
Cover	PC, black
Cable gland	PA, black, reinforced
Mounting bracket	Steel, galvanized
Connection	
Screw terminal	5 x 2 x 1 mm ²
Cable gland	PG 13.5 or 1/2" NPT for cable 6 to 10 mm
Weight	110 g
Approvals	UL, CSA
CE-marking	Yes

Connection Diagram

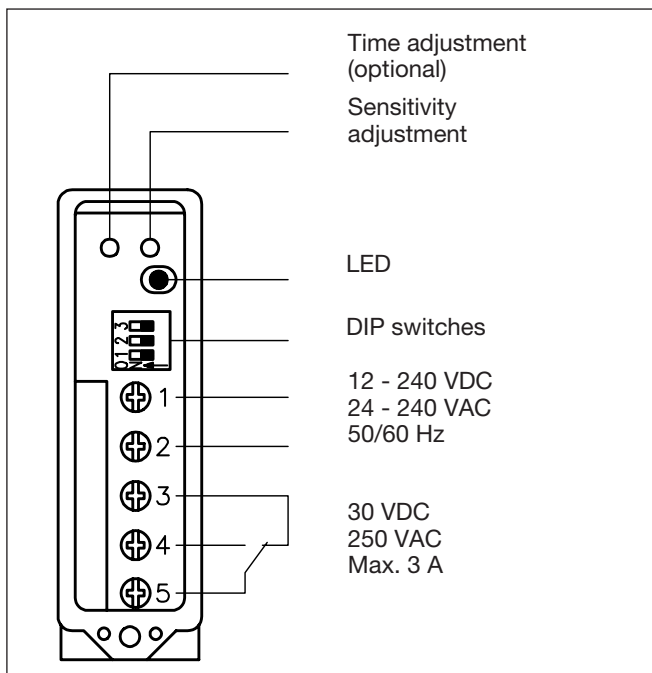











Delivery Contents

- Photoelectric switch: PMD 8R
- Cable gland
- Installation instruction
- Mounting bracket
- **Packaging:** Corrugated cardboard (environmentally friendly recycling material)

Accessories

- MB02 (longer mounting bracket), please refer to "Accessories"

Selection of Function

	Switch 1 2 3	
PMD 8R .		1 Break switching
		2 Make switching
PMD 8R .T		3 Delay on operate - Break switching
		4 Delay on operate - Make switching
		5 Delay on release - Break switching
		6 Delay on release - Make switching
		7 One shot, trailing edge - Break switching
		8 One shot, trailing edge - Make switching
		9 One shot, leading edge - Break switching
		10 One shot, leading edge - Make switching
		Don't care
		Upper position ON (Mode 1) Lower position OFF (Mode 0)

Reduction Factors

Reduction factors photoelectric switches	
Note: Real sensing distance = rated operating distance (S _n) x reduction factor	
Kodak test card, white, type R 27, 90% reflectivity	1.0
Dead black cardboard	0.1 - 0.4
Kodak test card, grey, type R 27	0.41 - 0.45
White Styropack	1.0 - 1.2
Bright metal	1.2 - 2.0
White cotton	0.5 - 0.8
Grey PVC	0.4 - 0.8
Raw wood	0.4 - 0.8
ER 1, reflector	0.3

Truth Table

	Make switching		Break switching	
	No	Yes	No	Yes
Object present	No	Yes	No	Yes
LED	OFF	ON	OFF	ON
Load	Non-active	Active	Active	Non-active

Operation Diagram

t = Time delay

tv = Power ON delay

Power supply

Object/target present

Func 1. Output ON

Func 2. Output ON

Func 3. Output ON

Func 4. Output ON

Func 5. Output ON

Func 6. Output ON

Func 7. Output ON

Func 8. Output ON

Func 9. Output ON

Func 10. Output ON

Dimensions

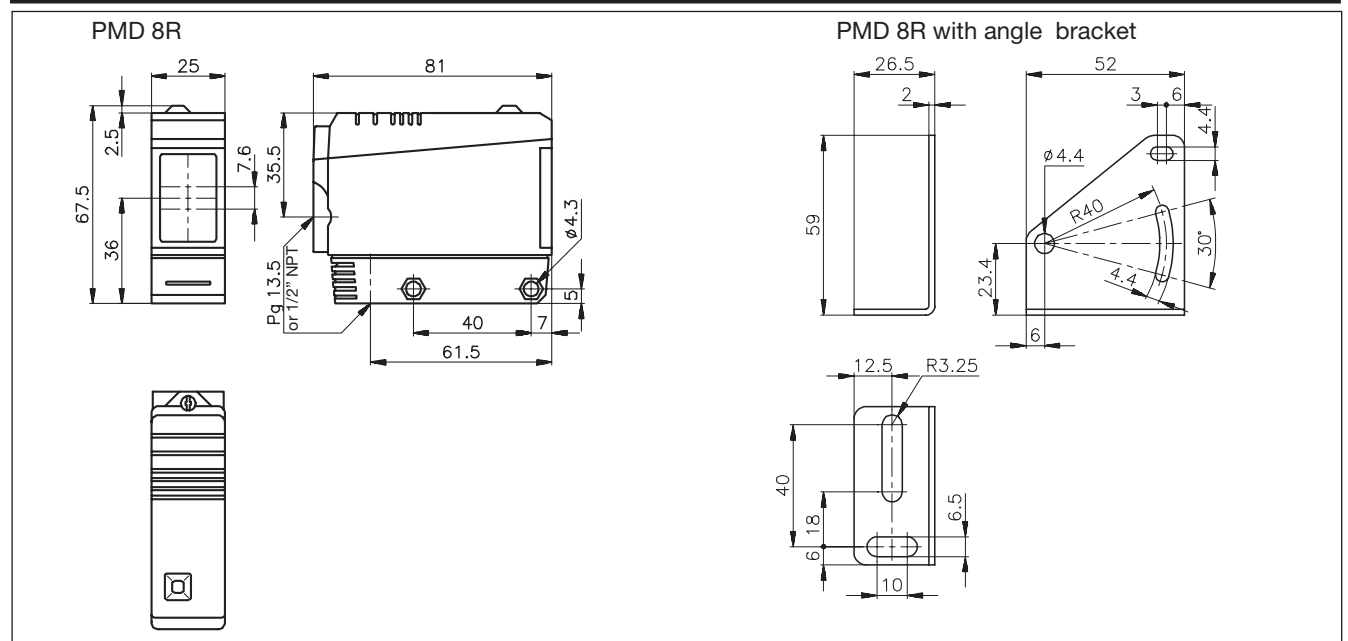

Installation Hints

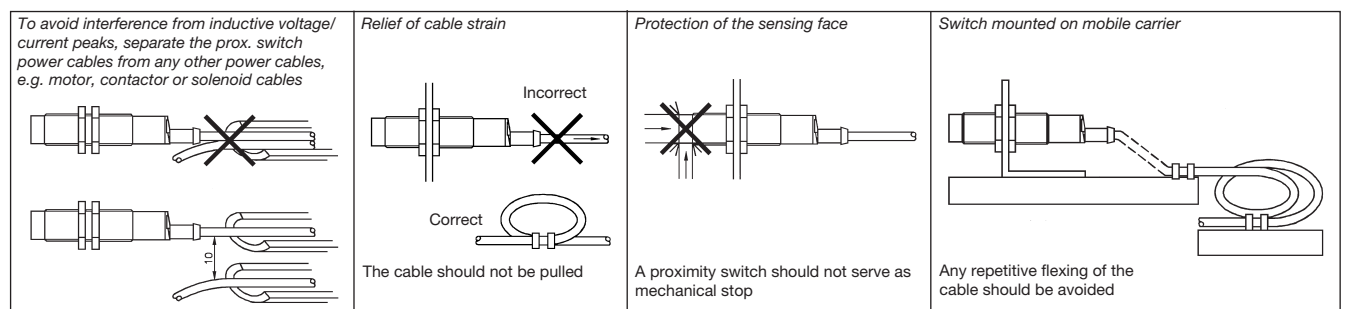

По вопросам продаж и поддержки обращайтесь:

Алматы (7273)495-231
Архангельск (8182)63-90-72
Астрахань (8512)99-46-04
Барнаул (3852)73-04-60
Белгород (4722)40-23-64
Брянск (4832)59-03-52
Владивосток (423)249-28-31
Волгоград (844)278-03-48
Вологда (8172)26-41-59
Воронеж (473)204-51-73
Екатеринбург (343)384-55-89
Иваново (4932)77-34-06
Ижевск (3412)26-03-58
Иркутск (395)279-98-46
Россия (495)268-04-70

Казань (843)206-01-48
Калининград (4012)72-03-81
Калуга (4842)92-23-67
Кемерово (3842)65-04-62
Киров (8332)68-02-04
Краснодар (861)203-40-90
Красноярск (391)204-63-61
Курск (4712)77-13-04
Липецк (4742)52-20-81
Магнитогорск (3519)55-03-13
Москва (495)268-04-70
Мурманск (8152)59-64-93
Набережные Челны (8552)20-53-41
Нижний Новгород (831)429-08-12
Киргизия (996)312-96-26-47

Новокузнецк (3843)20-46-81
Новосибирск (383)227-86-73
Омск (3812)21-46-40
Орел (4862)44-53-42
Оренбург (3532)37-68-04
Пенза (8412)22-31-16
Пермь (342)205-81-47
Ростов-на-Дону (863)308-18-15
Рязань (4912)46-61-64
Самара (846)206-03-16
Санкт-Петербург (812)309-46-40
Саратов (845)249-38-78
Севастополь (8692)22-31-93
Симферополь (3652)67-13-56
Казахстан (7172)727-132

Смоленск (4812)29-41-54
Сочи (862)225-72-31
Ставрополь (8652)20-65-13
Сургут (3462)77-98-35
Тверь (4822)63-31-35
Томск (3822)98-41-53
Тула (4872)74-02-29
Тюмень (3452)66-21-18
Ульяновск (8422)24-23-59
Уфа (347)229-48-12
Хабаровск (4212)92-98-04
Челябинск (351)202-03-61
Череповец (8202)49-02-64
Ярославль (4852)69-52-93