

RSC, RSO

Технические характеристики

По вопросам продаж и поддержки обращайтесь:

Алматы (7273)495-231	Казань (843)206-01-48	Новокузнецк (3843)20-46-81	Смоленск (4812)29-41-54
Архангельск (8182)63-90-72	Калининград (4012)72-03-81	Новосибирск (383)227-86-73	Сочи (862)225-72-31
Астрахань (8512)99-46-04	Калуга (4842)92-23-67	Омск (3812)21-46-40	Ставрополь (8652)20-65-13
Барнаул (3852)73-04-60	Кемерово (3842)65-04-62	Орел (4862)44-53-42	Сургут (3462)77-98-35
Белгород (4722)40-23-64	Киров (8332)68-02-04	Оренбург (3532)37-68-04	Тверь (4822)63-31-35
Брянск (4832)59-03-52	Краснодар (861)203-40-90	Пенза (8412)22-31-16	Томск (3822)98-41-53
Владивосток (423)249-28-31	Красноярск (391)204-63-61	Пермь (342)205-81-47	Тула (4872)74-02-29
Волгоград (844)278-03-48	Курск (4712)77-13-04	Ростов-на-Дону (863)308-18-15	Тюмень (3452)66-21-18
Вологда (8172)26-41-59	Липецк (4742)52-20-81	Рязань (4912)46-61-64	Ульяновск (8422)24-23-59
Воронеж (473)204-51-73	Магнитогорск (3519)55-03-13	Самара (846)206-03-16	Уфа (347)229-48-12
Екатеринбург (343)384-55-89	Москва (495)268-04-70	Санкт-Петербург (812)309-46-40	Хабаровск (4212)92-98-04
Иваново (4932)77-34-06	Мурманск (8152)59-64-93	Саратов (845)249-38-78	Челябинск (351)202-03-61
Ижевск (3412)26-03-58	Набережные Челны (8552)20-53-41	Севастополь (8692)22-31-93	Череповец (8202)49-02-64
Иркутск (395)279-98-46	Нижний Новгород (831)429-08-12	Симферополь (3652)67-13-56	Ярославль (4852)69-52-93
Россия (495)268-04-70	Киргизия (996)312-96-26-47	Казахстан (7172)727-132	

Motor Controllers

3-Phase Analog Power Controller

Types RSC-AAM60/RSO

CARLO GAVAZZI



- Control and output modules for analogue control of 3-phase induction motors or heaters
- Rated operational current: 3 x 10, 25, 50, 90, 110 AACrms
- Rated operational voltage: Up to 600 VACrms
- Supply voltage range: 10 to 32 VDC
- Control current range: 0 to 20 mA/4 to 20 mA
- LED-indication for line ON and load ON
- Varistor protection
- Approvals: CE, CCC, UL, CSA

Product Description

The micro processor based control module RSC-AAM60 is used with output modules RSO... to achieve a voltage controlled soft start/soft stop of 3-phase motors and a possibility for energy reduction when e.g. a fan is running with a variable capacity. This function is achieved by controlling the control module with a current between 4 and 20 mA (0 and 20 mA). The output mod-

ule can be selected according to the rated operational voltage and the size of the load.

This phase angle controlled soft-start unit can be used for pumps, fans, heaters, lights and many other applications.

LED indications for line ON and load ON gives a clear status indication.

Ordering Key

- Solid State Relay
- Soft starting/stopping
- Control module
- Output module
- Control input type
- Multivoltage
- Rated operational voltage
- Rated operational current

RSC-AA M 60

RSO 4050

Type Selection, Control Module

Control current	Mains	Max. operational voltage	Type Number
0-20 mA/4-20 mA	Multivoltage	600 VAC	RSC-AA M 60

Type Selection, Output Module

Rated operational voltage	Rated operational current				
	10 A	25 A	50 A	90 A	110 A
3 x 220 VAC	RSO 2210	RSO 2225	RSO 2250	RSO 2290	RSO 22110
3 x 400 VAC	RSO 4010	RSO 4025	RSO 4050	RSO 4090	RSO 40110
3 x 480 VAC	RSO 4810	RSO 4825	RSO 4850	RSO 4890	RSO 48110
3 x 600 VAC			RSO 6050	RSO 6090	RSO 60110

General Spec., Control Module

Operational voltage range Line to line	150 to 660 VACrms
Operational frequency range	45 to 65 Hz
Supply current @ no output current @ max. output current	< 30 mA < 180 mA
Supply voltage range	10 to 32 VDC
CE-marking	Yes
Approvals	UL, CSA, CCC

Control Specifications

Minimum output voltage	Power supply minus 8 VDC
Output current short-circuit protected	≤ 150 mA DC

Thermal Specifications

Operating temperature	-20° to +70°C (-4° to +158°F)
Storage temperature	-40° to +100°C (-40° to +212°F)

Control Input Specifications

Control current	
A-input	0 to 20 mA
B-input	4 to 20 mA
Input impedance	250 Ω
Power supply reset time	\leq 300 ms
Response time (input to trigger outputs)	\leq 1 cycle

Isolation Control Module

Rated isolation voltage Input to trigger outputs	\geq 4000 VACrms
-----------------------------------------------------	--------------------

Operation Diagram

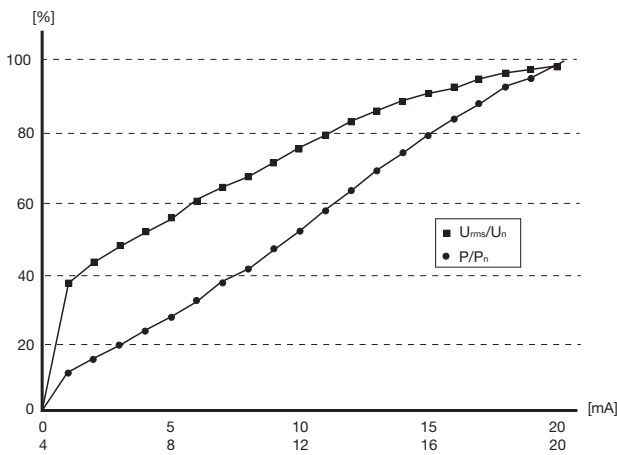

Output as a function of control current @cos(ϕ) = 0.9

Mode of Operation

The control module RSC-AAM60 is used with the output module RSO..... to achieve analog control of 3-phase induction motors.

Soft starting is achieved by increasing the motor voltage in accordance with the input current. Soft stopping is achieved by decreasing the motor voltage in accordance with the input current.

When the motor is running idle, the motor voltage can be reduced by lowering the input current, whereby energy is saved.

Heating elements can also be controlled with the RSC/RSO with the use of appropriate filters.

General Specifications, Output Module

	RSO 22...	RSO 40...	RSO 48...	RSO 60...
Operational voltage range Line to line	150 to 250 VACrms	220 to 420 VACrms	400 to 510 VACrms	400 to 625 VACrms
Blocking voltage	1200 V _p	1200 V _p	1200 V _p	1600 V _p
Varistor voltage	275 VAC	420 VAC	510 VAC	625 VAC
CE-marking	Yes	Yes	Yes	Yes

Output Specifications, Output Module

	RSO ..10	RSO ..25	RSO ..50	RSO ..90	RSO ..110
IEC and CCC Rated Operational Current AC 51	16 Arms	25 Arms	50 Arms	90 Arms	110 Arms
IEC and CCC rated operational current AC 53a	3 Arms	5 Arms	15 Arms	30 Arms	40 Arms
Number of starts/hr @40°C	7*	7*	7*	50*	50*
Overload cycle according to EN/ IEC 60947-4-2 @ 40°C	3A: AC53a: 4 - 4:100 - 7*	3A: AC53a: 4 - 4:100 - 7*	3A: AC53a: 4 - 4: 100 - 7*	3A: AC53a: 4 - 4:100 - 50*	3A: AC53a: 4 - 4: 100 - 50*
Off-state leakage current	\leq 10 mArms	\leq 10 mArms	\leq 10 mArms	\leq 25 mArms	\leq 25 mArms
On-state voltage drop	\leq 1.6 Vrms	\leq 1.6 Vrms	\leq 1.6 Vrms	\leq 1.8 Vrms	\leq 1.8 Vrms
I ² t for fusing t=10 ms	\leq 130 A ² s	\leq 525 A ² s	\leq 1800 A ² s	\leq 6600 A ² s	\leq 18000 A ² s
Non-rep. surge current t=10 ms	160 A _p	325 A _p	600 A _p	1150 A _p	1900 A _p

* Mounted on RHS 301

Thermal Specifications Output Module

	RSO ..10	RSO ..25	RSO ..50	RSO ..90	RSO ..110
Operating temperature	-20° to +70°C (-4° to +158°F)	-20° to +70°C (-4° to +158°F)	-20° to +70°C (-4° to +158°F)	-20° to +70°C (-4° to +158°F)	-20° to +70°C (-4° to +158°F)
Storage temperature	-40° to +100°C (-40° to +212°F)	-40° to +100°C (-40° to +212°F)	-40° to +100°C (-40° to +212°F)	-40° to +100°C (-40° to +212°F)	-40° to +100°C (-40° to +212°F)
Junction temperature	≤ 125°C	≤ 125°C	≤ 125°C	≤ 125°C	≤ 125°C
R_{th} junction to case	≤ 0.7 K/W	≤ 0.5 K/W	≤ 0.25 K/W	≤ 0.1 K/W	≤ 0.09 K/W

Functional Diagram

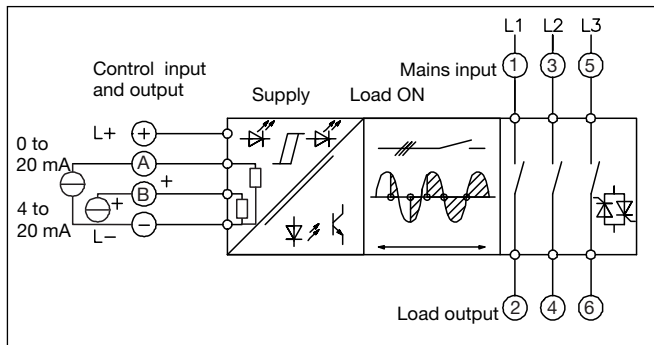

Wiring Diagram

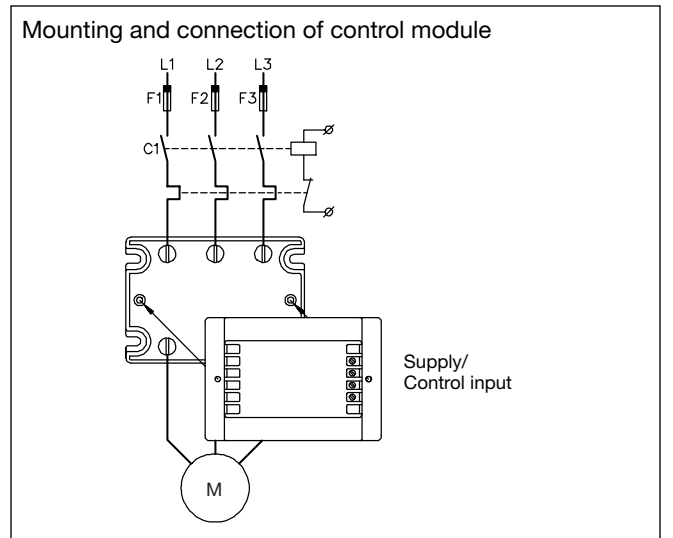

Accessories

- Heatsinks
- Fuses
- Temperature limit switch
- Power supply

For further information refer to "General Accessories".

Dimensions

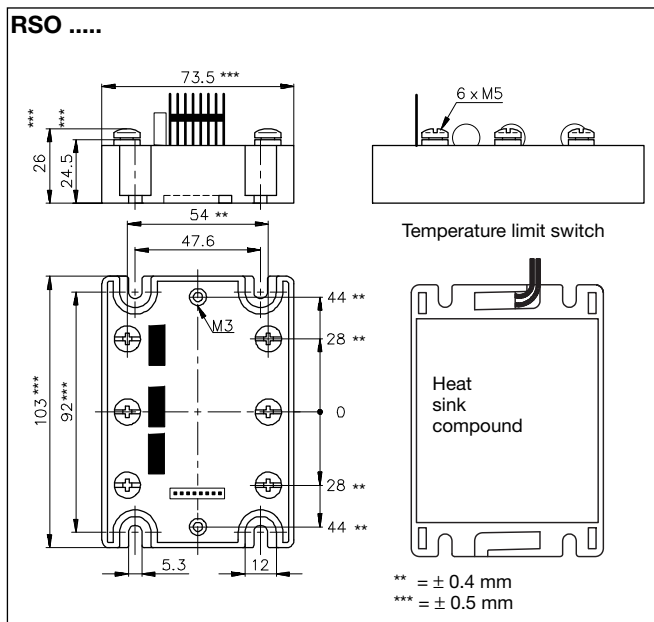

All dimensions in mm

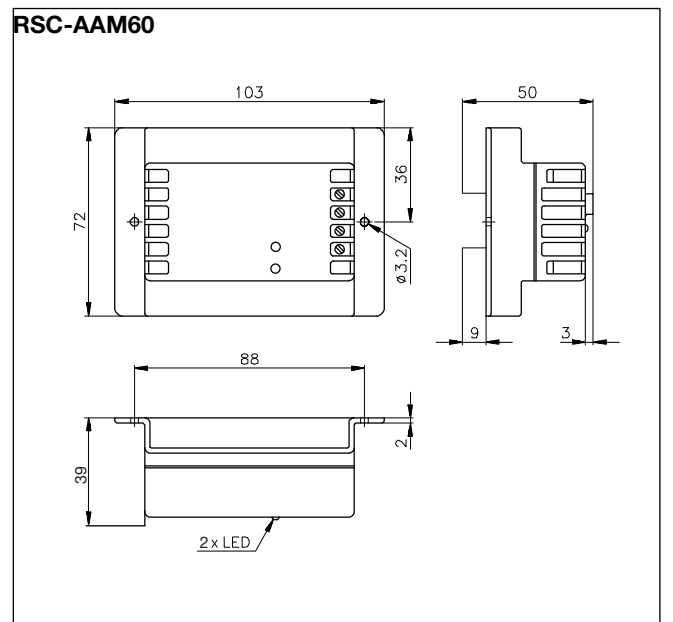

All dimensions in mm



Heatsink Dimensions (load current versus ambient temperature)

RSO ..10

Load current [A]	Thermal resistance [K/W]					Power dissipation [W]	Temp. protection [°C]
16	0.97	0.81	0.65	0.48	0.32	62	80°C
15	1.1	0.88	0.71	0.53	0.35	57	
14	1.2	0.97	0.77	0.58	0.39	52	
13	1.3	1.1	0.85	0.64	0.43	47	
12	1.4	1.2	0.95	0.71	0.47	42	
11	1.6	1.3	1.1	0.80	0.53	38	
10	1.8	1.5	1.2	0.90	0.60	33	
9	2.1	1.7	1.4	1	0.69	29	
7	2.8	2.3	1.9	1.4	0.93	21	
5	4.2	3.5	2.8	2.1	1.4	14	
3	7.4	6.2	4.9	3.7	2.5	8	
1	23.8	19.8	15.9	11.9	7.9	3	
	20	30	40	50	60	T _A	

RSO ..25

Load current [A]	Thermal resistance [K/W]					Power dissipation [W]	Temp. protection [°C]
25	0.66	0.55	0.44	0.33	0.22	91	80°C
22.5	0.76	0.63	0.51	0.38	0.25	79	
20	0.88	0.74	0.59	0.44	0.29	68	
17.5	1.1	0.87	0.70	0.52	0.35	57	
15	1.3	1.1	0.85	0.63	0.42	47	
12.5	1.6	1.3	1.1	0.79	0.53	38	
10	2.1	1.7	1.4	1	0.69	29	
7.5	2.9	2.4	1.9	1.4	0.96	21	
5	4.5	3.8	3	2.3	1.5	13	
2.5	9.4	7.8	6.3	4.7	3.1	6	
	20	30	40	50	60	T _A	

RSO ..50

Load current [A]	Thermal resistance [K/W]					Power dissipation [W]	Temp. protection [°C]
50	0.33	0.28	0.22	0.16	0.11	181	80°C
45	0.38	0.32	0.25	0.19	0.13	158	
40	0.44	0.37	0.29	0.22	0.15	136	
35	0.52	0.43	0.35	0.26	0.17	116	
30	0.63	0.52	0.42	0.31	0.21	96	
25	0.78	0.65	0.52	0.39	0.26	77	
20	1	0.84	0.67	0.50	0.34	60	
15	1.4	1.2	0.93	0.69	0.46	43	
10	2.2	1.8	1.4	1.1	0.72	28	
5	4.5	3.8	3	2.3	1.5	13	
	20	30	40	50	60	T _A	Ambient temp. [°C]

RSO ..90, RSO ..110

Load current [A]	Heatsink/Thermal resistance [K/W]					Power dissipation [W]	Temp. protection [°C]
90	0.13	0.10	0.07	0.04	-	304	80°C
80	0.19	0.15	0.12	0.08	0.04	260	
70	0.27	0.22	0.18	0.13	0.09	219	
60	0.33	0.28	0.22	0.17	0.11	181	
50	0.41	0.35	0.28	0.21	0.14	145	
40	0.54	0.45	0.36	0.27	0.18	111	
30	0.75	0.63	0.50	0.38	0.25	80	
20	1.2	0.99	0.79	0.59	0.39	51	
10	2.5	2.1	1.7	1.2	0.83	24	
	20	30	40	50	60	T _A	

Heatsink Selection

Carlo Gavazzi Heatsink (see Accessories)	Thermal resistance
No heatsink required	$R_{th\ s-a} > 8.0$ K/W
RHS 300 Assy or backplate	5.0 K/W
RHS 301 Assy	0.8 K/W
RHS 301 F Assy	0.25 K/W
Consult your distributor	< 0.25 K/W

Compare the value found in the load current versus temperature chart with the standard heatsink values and select the heatsink with the next lower value.

It is recommended to protect the solid state relay against overheating. Therefore the chart also states the maximum switching temperature (70, 80 or 90 °C) for the optional temperature limit switch.

Housing Specifications

Weight RSO ..10, ..25, ..50 RSO ..90, ..110	Approx. 275 g Approx. 385 g	Relay Mounting screws Mounting torque	M5 ≤ 1.5 Nm
Housing material Colour	Noryl, glass-reinforced Black	Control terminal Mounting screws Mounting torque	M3 ≤ 0.5 Nm
Base plate @ ≤ 50 A @ ≥ 90 A	Aluminium, nickel-plated Copper, nickel-plated	Power terminal Mounting screws Mounting torque	M5 x 6 ≤ 1.5 Nm
Potting compound	Polyurethane, black		

Applications

The output module RSO ..110 is recommended for motors up to 22 kW @ 400 V. The RSO ..110 is designed for use in applications with high surge current conditions. Care must be taken to ensure proper heat-sinking when the relays are to be used at high nominal currents. Adequate electrical connection between relay terminals and cable must be ensured.

Example 1: Power dissipation - RSO 40110:

$I_{load} = 40 \text{ Arms} = 111 \text{ W}$
See previous page.

Example 2:

Motor: 3 kW, 4 HP
3 x 400 VAC, 4-pole
 $T_A: 50^\circ\text{C}$
Starting time: ≤ 5 s

For this application RSC-AAM60 must be used. The output module RSO4025 is selected according to the Selection Guide.

The smallest heatsink required is 1 K/W, and the power dissipation is 25 W.

This gives:
Control module:
RSC-AAM60
Output module: RSO 4025
Heatsink: 1K/W

Connection to the mains

Since no motor protective circuitry is included in the RSC/RSO, the motor must be protected in the usual way, i.e. either by a thermal relay, a PTC-resistor or a Klixon bimetal temperature switch near the motor windings.

If short circuit protection is required, fuses F1 to F3 should be ultrafast and selected according to the load integral (I^2t) of the RSO output module and the motor load.

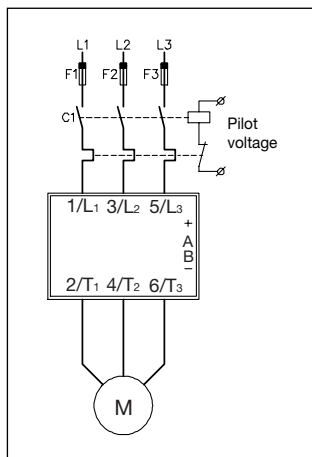

Overload protection by thermal relay

Transient voltage protection

With an unfiltered main supply, voltage transient may occur. Since these transients could have a high energy content, it is advisable to use varistors to protect the output module.

The varistors are already mounted in the RSO output module and they are selected according to the rated operational voltage.

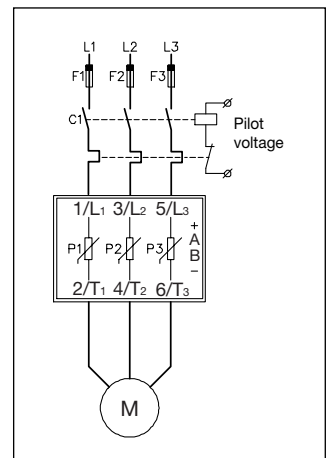

Energy saving for motors in idle mode

When motors are running idle, it not necessary to maintain a full magnetic field, as is the case when the motor has to produce full torque. By lowering the motor voltage, power losses inside the motor are also reduced.

When the motor is idle, d1 will switch the control current from $I_1 > 20 \text{ mA}$ to I_2 , which is adjusted to a value at which the motor is still running at full speed, but at a lower voltage. Please remark that this type of phase-angle controlled voltage reduction, demands additional filtering to fulfill EMC regulations.

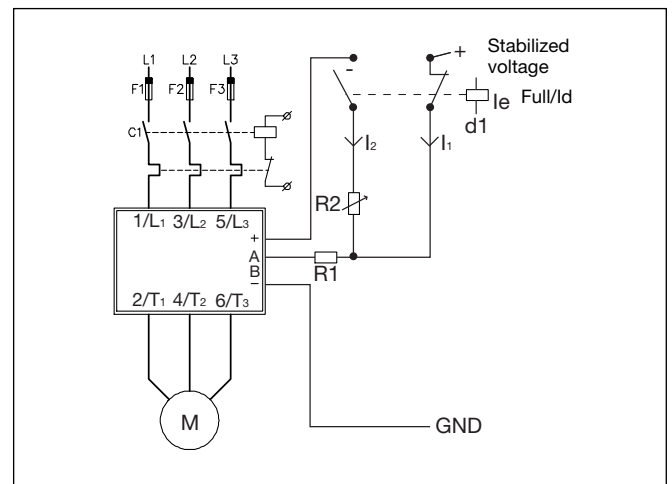

Applications (cont.)

In order to achieve a 4 to 20 mA signal from a 12 or 24 VDC source, a resistor and a potentiometer should be connected in series with the voltage source and the RSC controller.

We define the I_{max} to be e.g. 24 mA, which means that the series resistors must be:

$$R_1 (12 V) = U/I - R_{int} = 12 V/24 mA - 250 \Omega = 250 \Omega$$

$$R_1 (24 V) = U/I - R_{int} = 24 V/24 mA - 250 \Omega = 750 \Omega$$

If the minimum current is defined to be e.g. 2.4 mA and the 250 Ω R_{int} input resistance of the RSC is also calculated in:

$$R_2 (12 V) = U/I - R_1 - R_{int} = 12/2.4 - 250 - 250 = 4500 \Omega$$

$$R_2 (24 V) = U/I - R_1 - R_{int} = 24/2.4 - 750 - 250 = 9000 \Omega$$

Selection Guide

400 VACrms and 480 VACrms motors

Output module	RSO ..10	RSO ..25	RSO ..50	RSO ..90	RSO ..110
Max. motor size	3 HP/2.2 kW	5 HP/4 kW	15 HP/11 kW	20 HP/15 kW	30 HP/22 kW

600 VACrms motors

Output module			RSO 6050	RSO 6090	RSO 60110
Max. motor size			15 HP	30 HP	40 HP

Wiring Diagram (0-10 VDC control)

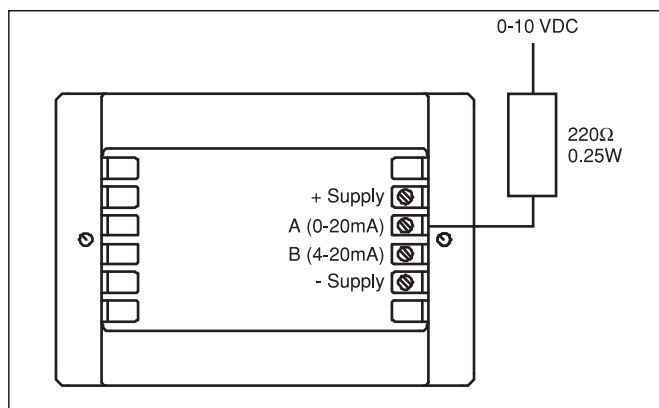

Short circuit Protection (according to EN/IEC 60947-4-2)

Type of coordination: 2

Rated short circuit current

RSO...25 RSO...10	RSO...50	RSO...90	RSO...110
5kA when protected by semiconductor fuses. Ferraz Shawmut 25A, Class URQ Art. No. 6.9 CP gRC 14.51/ 25	5kA when protected by semiconductor fuses. Ferraz Shawmut 63A, Class URQ Art. No. 6.921 CP URQ 27 x 60/ 63	5kA when protected by semiconductor fuses. Ferraz Shawmut 80A, Class URQ Art. No. 6.921 CP URQ 27 x 60/ 80	5kA when protected by semiconductor fuses. Ferraz Shawmut 100A, Class URQ Art. No. 6.921 CP URQ 27 x 60/ 100

Motor Controllers Soft Starting/Soft Stopping Types RSC -HD0M60/RSO.....

CARLO GAVAZZI



- Control and output modules for soft starting/stopping of 3-phase induction motors
- Rated operational current: 3 x 10, 25, 50, 90, 110 AACrms
- Rated operational voltage: Up to 600 VACrms
- Control voltage range: 10 to 32 VDC
- LED-indication for line ON and load ON
- Varistor protection

Product Description

The microprocessor based control module RSC-HD0M60 is used with output modules RSO.... to achieve full wave soft starting and soft stopping of 3-phase induction motors. When the motor is fully operating, the module delivers a signal which can be used to connect a contactor in parallel with the output module, thereby limiting the power dis-

sipation of the device and eliminating the need for a large heatsink. The power supply unit MS1* has a built-in control relay for shunting the motor controller when soft starting is performed. The standard control module is multivoltage compatible and features LED indication for line ON and load ON.

* refer to MS1 datasheet

Ordering Key

RSC-HD 0 M 60

- Solid State Relay
- Soft starting/stopping
- Control module
- Output module
- Control input type
- Shape of ramp
- Multivoltage
- Max. operational current
- Max. operational voltage

RSO 4050

Type Selection, Control Module

Control voltage	Shape of Ramp	Mains	Max. operational voltage	Type Number
10 - 32 VDC	Linear	Multivoltage	600 VAC	RSC-HD 0 M 60

Type Selection, Output Module

Rated operational voltage	Rated operational current				
	10 A	25 A	50 A	90 A	110 A
3 x 220 VAC	RSO 2210	RSO 2225	RSO 2250	RSO 2290	RSO 22110
3 x 400 VAC	RSO 4010	RSO 4025	RSO 4050	RSO 4090	RSO 40110
3 x 480 VAC	RSO 4810	RSO 4825	RSO 4850	RSO 4890	RSO 48110
3 x 600 VAC			RSO 6050	RSO 6090	RSO 60110

General Spec., Control Module

Operational voltage range Line to line	150 to 660 VACrms
Operational frequency range	45 to 65 Hz
Supply current @ no output current @ max. output current	< 30 mA < 180 mA
CE-marking	Yes
Approvals	UL, CSA

Control Output Specifications

Minimum output voltage	Power supply minus 8 VDC
Output current short-circuit protected	≤ 150 mA DC

Thermal Specifications

Operating temperature	-20° to +70°C (-4° to +158°F)
Storage temperature	-40° to +100°C (-40° to 212°F)

Control Input Specifications

Control voltage range	10 to 32 VDC
Ramp up function	≥ 8 VDC
Ramp down function	≤ 3 VDC
Input current	≤ 1 mA @ 32 VDC
Adjust. starting torque	10 to 75%
Adjust. ramp up time	0.5 to 30 s
Adjust. ramp down time	0.5 to 30 s
Response time (input to trigger outputs)	≤ 50 ms
Time to initialize after powerloss	< 300 ms

Isolation Control Module

Rated isolation voltage Input to trigger outputs	≥ 4000 VACrms
-----------------------------------------------------	--------------------

Accessories

Heatsinks	For further information refer to "General Accessories".
Fuses	
Temperature limit switch	
Power supply	

Operation Diagram

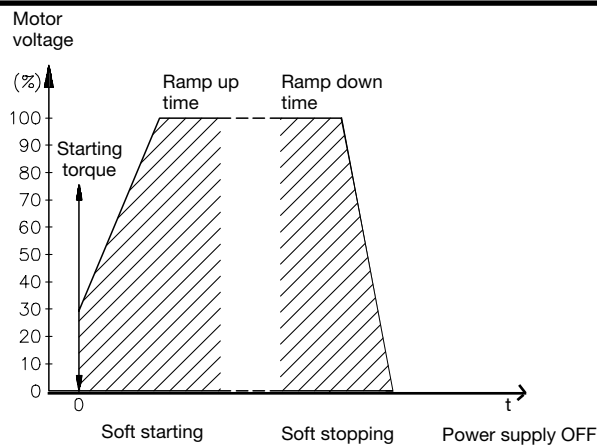

Mode of Operation

The control module RSC-HD0M60 is used with the output module RSO.. to achieve soft starting and soft stopping of 3-phase induction motors. Soft starting is achieved by increasing the motor voltage in accordance with the setting of the ramp up time potentiometer within the range of 0.5 to 30 s. Soft stopping is achieved by decreasing the motor voltage in accordance with the setting of the ramp down time potentiometer within the range of 0.5 to 30 s.

The starting torque potentiometer makes it possible to adjust the starting level of the motor voltage to a value at which the motor starts to rotate immediately when soft starting is initiated. When the motor is fully operating, an output signal appears which can be used to connect a bypassing relay or contactor in parallel to the output module, thus limiting the need for cooling. Note: Only delta/star without neutral.

General Specifications, Output Module

	RSO 22...	RSO 40...	RSO 48...	RSO 60...
Operational voltage range Line to line	150 to 250 VACrms	220 to 420 VACrms	400 to 510 VACrms	400 to 625 VACrms
Blocking voltage	1200 V _p	1200 V _p	1200 V _p	1600 V _p
Varistor voltage	275 VAC	420 VAC	510 VAC	625 VAC
CE-marking	Yes	Yes	Yes	Yes

Output Specifications, Output Module

	RSO ..10	RSO ..25	RSO ..50	RSO ..90	RSO ..110
Rated operational current AC 51 AC 53a	16 Arms 3 Arms	25 Arms 5 Arms	50 Arms 15 Arms	90 Arms 30 Arms	110 Arms 40 Arms
Off-state leakage current	≤ 10 mArms	≤ 10 mArms	≤ 10 mArms	≤ 25 mArms	≤ 25 mArms
On-state voltage drop	≤ 1.6 Vrms	≤ 1.6 Vrms	≤ 1.6 Vrms	≤ 1.8 Vrms	≤ 1.8 Vrms
I ² t for fusing t=10 ms	≤ 130 A ² s	≤ 525 A ² s	≤ 1800 A ² s	≤ 6600 A ² s	≤ 18000 A ² s
Non-rep. surge current t=10 ms	160 A _p	325 A _p	600 A _p	1150 A _p	1900 A _p

Thermal Specifications Output Module

	RSO ..10	RSO ..25	RSO ..50	RSO ..90	RSO ..110
Operating temperature	-20° to +70°C (-4° to +158°F)	-20° to +70°C (-4° to +158°F)	-20° to +70°C (-4° to +158°F)	-20° to +70°C (-4° to +158°F)	-20° to +70°C (-4° to +158°F)
Storage temperature	-40° to +100°C (-40° to +212°F)	-40° to +100°C (-40° to +212°F)	-40° to +100°C (-40° to +212°F)	-40° to +100°C (-40° to +212°F)	-40° to +100°C (-40° to +212°F)
Junction temperature	≤ 125°C	≤ 125°C	≤ 125°C	≤ 125°C	≤ 125°C
R _{th} junction to case	≤ 0.7 K/W	≤ 0.5 K/W	≤ 0.25 K/W	≤ 0.1 K/W	≤ 0.09 K/W

Insulation Output Module

Rated insulation voltage
Output to case ≥4000 VACrms

Functional Diagram

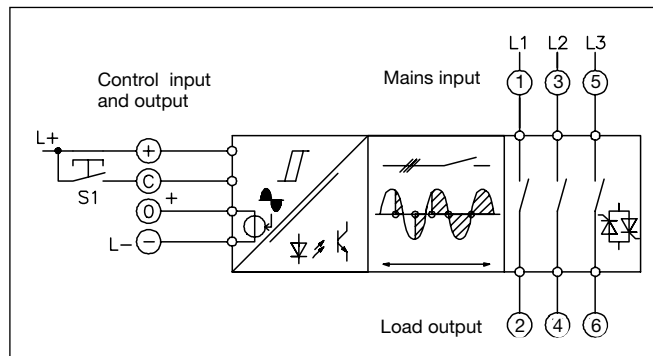

Wiring Diagram

Mounting and connection of control module

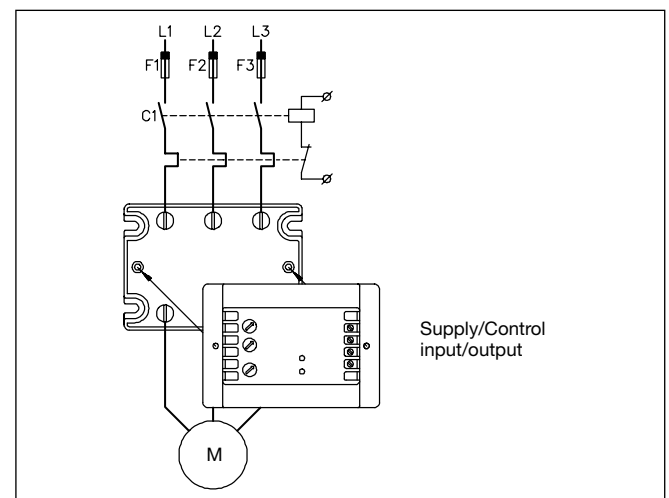

Dimensions

RSO

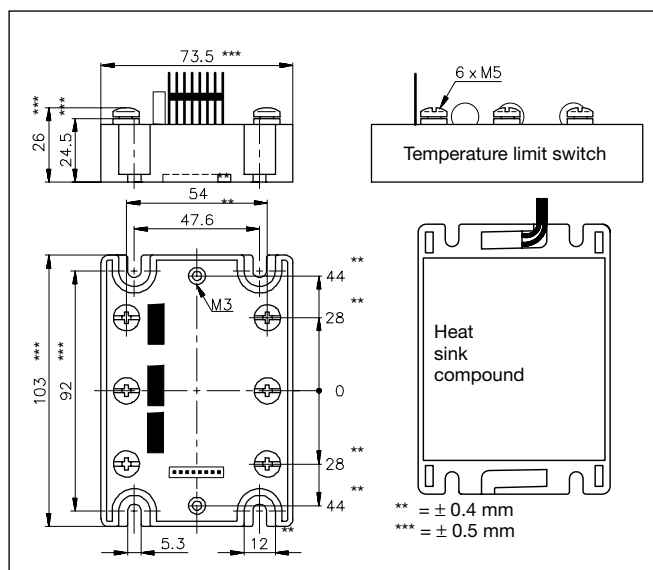

All dimensions in mm

RSC-HD0M60

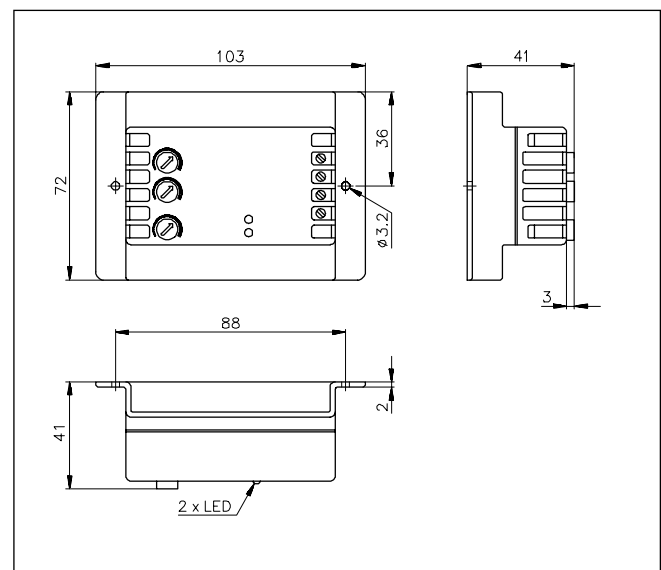

All dimensions in mm



Heatsink Dimensions (load current versus ambient temperature)

RSO ..10

Load current [A]	Thermal resistance [K/W]					Power dissipation [W]	Temp. protection [°C]
16	0.97	0.81	0.65	0.48	0.32	62	80°C
15	1.1	0.88	0.71	0.53	0.35	57	
14	1.2	0.97	0.77	0.58	0.39	52	
13	1.3	1.1	0.85	0.64	0.43	47	
12	1.4	1.2	0.95	0.71	0.47	42	
11	1.6	1.3	1.1	0.80	0.53	38	
10	1.8	1.5	1.2	0.90	0.60	33	
9	2.1	1.7	1.4	1	0.69	29	
7	2.8	2.3	1.9	1.4	0.93	21	
5	4.2	3.5	2.8	2.1	1.4	14	
3	7.4	6.2	4.9	3.7	2.5	8	
1	23.8	19.8	15.9	11.9	7.9	3	
	20	30	40	50	60	T _A	Ambient temp. [°C]

RSO ..25

Load current [A]	Thermal resistance [K/W]					Power dissipation [W]	Temp. protection [°C]	
25	0.66	0.55	0.44	0.33	-	91	80°C	
22.5	0.76	0.63	0.51	0.38	0.25	79		
20	0.88	0.74	0.59	0.44	0.29	68		
17.5	1.1	0.87	0.70	0.52	0.35	57		
15	1.3	1.1	0.85	0.63	0.42	47		
12.5	1.6	1.3	1.1	0.79	0.53	38		
10	2.1	1.7	1.4	1	0.69	29		
7.5	2.9	2.4	1.9	1.4	0.96	21		
5	4.5	3.8	3	2.3	1.5	13		
2.5	9.4	7.8	6.3	4.7	3.1	6		
	20	30	40	50	60	T _A		Ambient temp. [°C]

RSO ..50

Load current [A]	Thermal resistance [K/W]					Power dissipation [W]	Temp. protection [°C]
50	0.33	0.28	-	-	-	181	80°C
45	0.38	0.32	0.25	-	-	158	
40	0.44	0.37	0.29	-	-	136	
35	0.52	0.43	0.35	0.26	-	116	
30	0.63	0.52	0.42	0.31	-	96	
25	0.78	0.65	0.52	0.39	0.26	77	
20	1	0.84	0.67	0.50	0.34	60	
15	1.4	1.2	0.93	0.69	0.46	43	
10	2.2	1.8	1.4	1.1	0.72	28	
5	4.5	3.8	3	2.3	1.5	13	
	20	30	40	50	60	T _A	Ambient temp. [°C]

RSO ..90, RSO ..110

Load current [A]	Heatsink/Thermal resistance [K/W]					Power dissipation [W]	Temp. protection [°C]
90	-	-	-	-	-	304	80°C
80	-	-	-	-	-	260	
70	0.27	-	-	-	-	219	
60	0.33	0.28	-	-	-	181	
50	0.41	0.35	0.28	-	-	145	
40	0.54	0.45	0.36	0.27	-	111	
30	0.75	0.63	0.50	0.38	0.25	80	
20	1.2	0.99	0.79	0.59	0.39	51	
10	2.5	2.1	1.7	1.2	0.83	24	
	20	30	40	50	60	T _A	

Heatsink Selection

Carlo Gavazzi Heatsink (see Accessories)	Thermal resistance
No heatsink required	$R_{th\ s-a} > 8.0$ K/W
RHS 300 Assy or backplate	5.0 K/W
RHS 301 Assy	0.8 K/W
RHS 301 F Assy	0.25 K/W
Consult your distributor	< 0.25 K/W

Compare the value found in the load current versus temperature chart with the standard heatsink values and select the heatsink with the next lower value.

It is recommended to protect the solid state relay against overheating. Therefore the chart also states the maximum switching temperature (70, 80 or 90 °C) for the optional temperature limit switch.

Housing Specifications

Weight RSO ..10, ..25, ..50 RSO ..90, ..110	Approx. 275 g Approx. 385 g	Relay Mounting screws Mounting torque	M5 ≤ 1.5 Nm
Housing material Colour	Noryl, glass-reinforced Black	Control terminal Mounting screws Mounting torque	M3 ≤ 0.5 Nm
Base plate @ ≤ 50 A @ ≥ 90 A	Aluminium, nickel-plated Copper, nickel-plated	Power terminal Mounting screws Mounting torque	M5 x 6 ≤ 1.5 Nm
Potting compound	Polyurethane, black		

Applications

The output module RSO ..110 is recommended for motors up to 22 kW @ 400 V. The RSO ..110 is designed for use in applications with high surge current conditions. Care must be taken to ensure proper heat-sinking when the output modules are to be used at high nominal currents. Adequate electrical connection between relay terminals and cable must be ensured.

Example 1: Power dissipation - RSO 40110:

$I_{load} = 40 \text{ Arms} = 111 \text{ W}$
See previous page.

Example 2:
Motor: 3 kW, ns = 1500 rpm,
3 x 400 VAC, 4-pole
 $T_A: 50^\circ\text{C}$
Starting time: ≤ 5 s

The RSC-HD0M60 is used for both applications. The RSO ..50, RSO ..25, RSO ..10 modules can be used: RSO ..50, if the starting current is unknown for 5 s (starting time) and a large safety margin is required, RSO ..25/..10, if during starting the current is lower. For RSO ..10 the maximum current is 17 A for 5 s, and for RSO ..25 the maximum current is 39 A for 5 s. In this application the starting current is measured to be only 17 A with a starting time of 5 s. Consequently, an RSO ..10 is selected.

The min. heatsink is 1K/W, and the power dissipation is 25 W.

This gives:
Control module:
RSC-HD.M60
Output module: RSO 4010
Heatsink:1K/W

Note: The thermal conditions have now been designed for the nominal motor current. This means that the starting time should be less than 10% of the operating time of the motor.

Connection to the mains
Since no motor protective circuitry is included in the RSC/RSO, the motor must be protected in the usual way, i.e. either by a thermal relay, a PTC-resistor or a Klixon bimetal temperature switch near the motor windings.

If short circuit protection is required, fuses F1 to F3 should be ultrafast and selected according to the load integral (I^2t) of the RSO output module and the motor load.

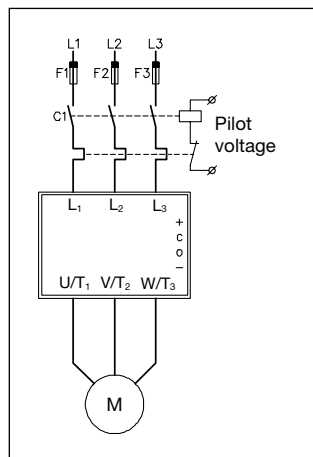

Overload protection by thermal relay

Mains-controlled soft starting

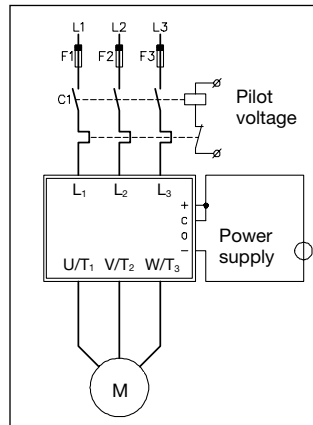

When the main contactor C1 switches on, the motor will soft-start. When C1 switches off, the SSR automatically resets.

Note: The induced voltage from the motor will prolong the reset, depending on motor type and load.

Manual start - stop function

If desired, an external control circuit for manual starting and stopping can be created by using push buttons. When the start button is pressed and held until the lamp B1 is lit (indicating that the motor is now running), a holding contact is made. The motor will stop after activating the stop button.

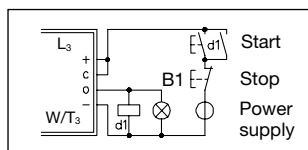

Input-controlled soft starting

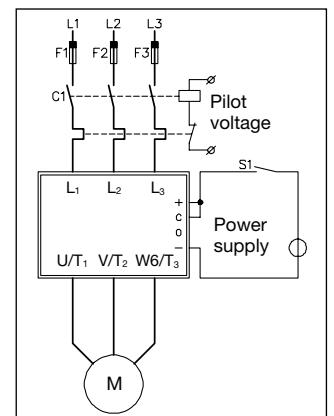

When the main contactor C1 switches ON, and the control switch S1 is closed, the motor will soft-start. When either C1 or S1 switches OFF, the SSR will automatically reset.

Soft-starting and soft stopping

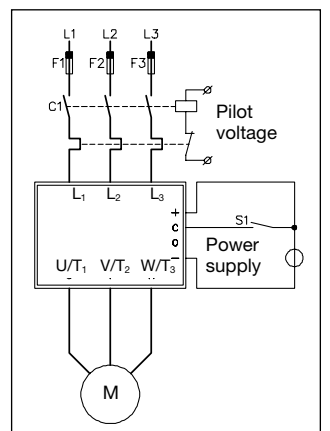

When the main contactor C1 switches on, and the control switch S1 is closed, the motor will soft-start. When S1 is opened, the motor will soft-stop.

Applications (cont.)

Shunting the output module

This circuit limits the power dissipation of the SSR and consequently eliminates the need for a large heatsink, i.e. the power dissipation is limited to the starting and stopping periods. This is achieved by switching a contactor with the output signal from the control module RSC. In this case C2 is carrying - not switching - the current and can therefore be rated on the basis of the

thermal current data of the contacts, which will result in a smaller contactor.

Note: However, if C2 fails, the temperature on the output module RSO heatsink may rise to an unacceptable level. It is therefore advisable to protect the RSO by means of an optional temperature limiting switch T1, which can be inserted in the housing of the output module.

The MS1 .. Power Supply connected to a motor controller (RSC) for soft starting/soft stopping of an induction motor.

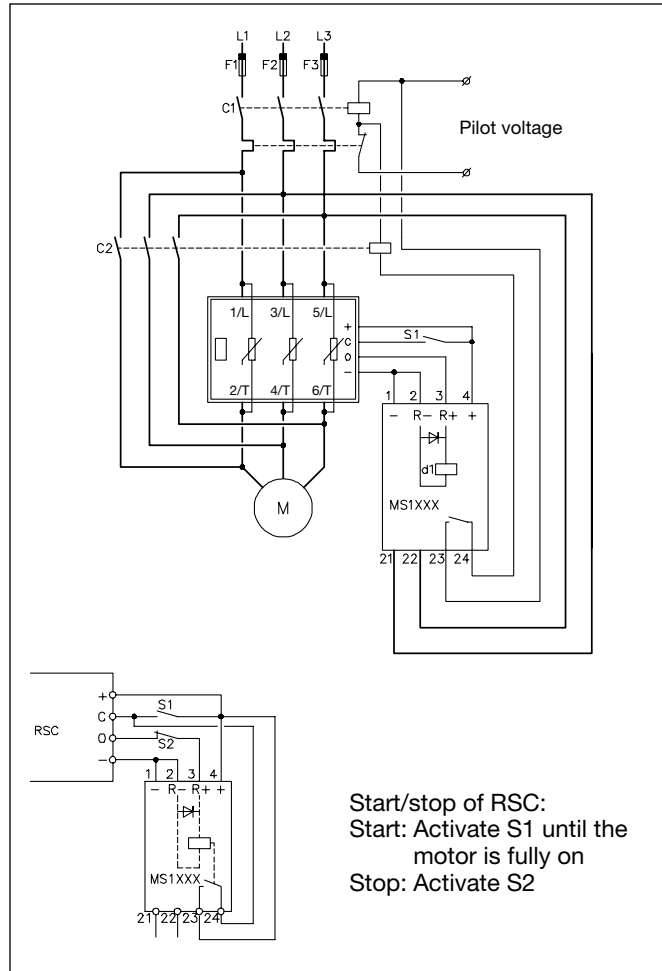
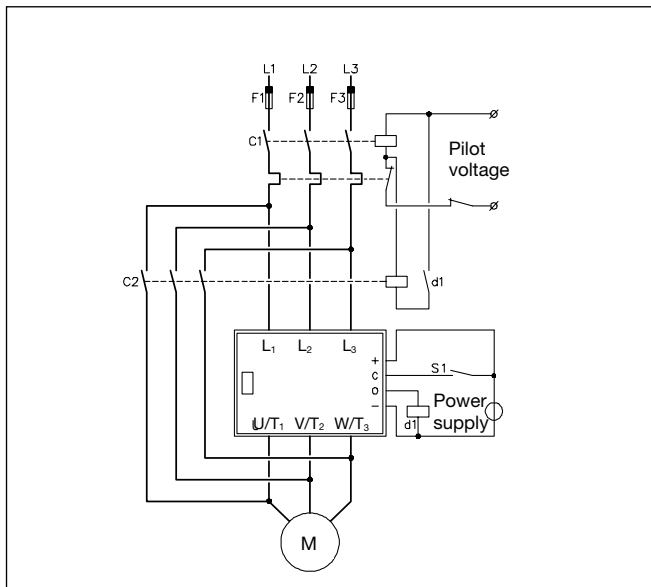

Selection Guide

400 VACrms and 480 VACrms motors

Output module	RSO 4.10	RSO 4.25	RSO 4.50	RSO 4.90	RSO 4.110
Max. motor size	3 HP/2.2 kW	5 HP/4 kW	15 HP/11 kW	20 HP/15 kW	30 HP/22 kW

600 VACrms motors

Output module			RSO 6050	RSO 6090	RSO 60110
Max. motor size			15 HP	30 HP	40 HP

По вопросам продаж и поддержки обращайтесь:

Алматы (7273)495-231
Архангельск (8182)63-90-72
Астрахань (8512)99-46-04
Барнаул (3852)73-04-60
Белгород (4722)40-23-64
Брянск (4832)59-03-52
Владивосток (423)249-28-31
Волгоград (844)278-03-48
Вологда (8172)26-41-59
Воронеж (473)204-51-73
Екатеринбург (343)384-55-89
Иваново (4932)77-34-06
Ижевск (3412)26-03-58
Иркутск (395)279-98-46
Россия (495)268-04-70

Казань (843)206-01-48
Калининград (4012)72-03-81
Калуга (4842)92-23-67
Кемерово (3842)65-04-62
Киров (8332)68-02-04
Краснодар (861)203-40-90
Красноярск (391)204-63-61
Курск (4712)77-13-04
Липецк (4742)52-20-81
Магнитогорск (3519)55-03-13
Москва (495)268-04-70
Мурманск (8152)59-64-93
Набережные Челны (8552)20-53-41
Нижний Новгород (831)429-08-12
Киргизия (996)312-96-26-47

Новокузнецк (3843)20-46-81
Новосибирск (383)227-86-73
Омск (3812)21-46-40
Орел (4862)44-53-42
Оренбург (3532)37-68-04
Пенза (8412)22-31-16
Пермь (342)205-81-47
Ростов-на-Дону (863)308-18-15
Рязань (4912)46-61-64
Самара (846)206-03-16
Санкт-Петербург (812)309-46-40
Саратов (845)249-38-78
Севастополь (8692)22-31-93
Симферополь (3652)67-13-56
Казахстан (7172)727-132

Смоленск (4812)29-41-54
Сочи (862)225-72-31
Ставрополь (8652)20-65-13
Сургут (3462)77-98-35
Тверь (4822)63-31-35
Томск (3822)98-41-53
Тула (4872)74-02-29
Тюмень (3452)66-21-18
Ульяновск (8422)24-23-59
Уфа (347)229-48-12
Хабаровск (4212)92-98-04
Челябинск (351)202-03-61
Череповец (8202)49-02-64
Ярославль (4852)69-52-93