

RSQK

Технические характеристики

По вопросам продаж и поддержки обращайтесь:

Алматы (7273)495-231	Казань (843)206-01-48	Новокузнецк (3843)20-46-81	Смоленск (4812)29-41-54
Архангельск (8182)63-90-72	Калининград (4012)72-03-81	Новосибирск (383)227-86-73	Сочи (862)225-72-31
Астрахань (8512)99-46-04	Калуга (4842)92-23-67	Омск (3812)21-46-40	Ставрополь (8652)20-65-13
Барнаул (3852)73-04-60	Кемерово (3842)65-04-62	Орел (4862)44-53-42	Сургут (3462)77-98-35
Белгород (4722)40-23-64	Киров (8332)68-02-04	Оренбург (3532)37-68-04	Тверь (4822)63-31-35
Брянск (4832)59-03-52	Краснодар (861)203-40-90	Пенза (8412)22-31-16	Томск (3822)98-41-53
Владивосток (423)249-28-31	Красноярск (391)204-63-61	Пермь (342)205-81-47	Тула (4872)74-02-29
Волгоград (844)278-03-48	Курск (4712)77-13-04	Ростов-на-Дону (863)308-18-15	Тюмень (3452)66-21-18
Вологда (8172)26-41-59	Липецк (4742)52-20-81	Рязань (4912)46-61-64	Ульяновск (8422)24-23-59
Воронеж (473)204-51-73	Магнитогорск (3519)55-03-13	Самара (846)206-03-16	Уфа (347)229-48-12
Екатеринбург (343)384-55-89	Москва (495)268-04-70	Санкт-Петербург (812)309-46-40	Хабаровск (4212)92-98-04
Иваново (4932)77-34-06	Мурманск (8152)59-64-93	Саратов (845)249-38-78	Челябинск (351)202-03-61
Ижевск (3412)26-03-58	Набережные Челны (8552)20-53-41	Севастополь (8692)22-31-93	Череповец (8202)49-02-64
Иркутск (395)279-98-46	Нижний Новгород (831)429-08-12	Симферополь (3652)67-13-56	Ярославль (4852)69-52-93
Россия (495)268-04-70	Киргизия (996)312-96-26-47	Казахстан (7172)727-132	

Motor Controllers

AC Semiconductor Motor Controller

Type RSQK

CARLO GAVAZZI



- Soft starting, soft stopping of 3-phase induction motors
- Energy optimising 3-phase controlled softstarter
- Adjustable integrated overload protection
- Operational voltage: 230-460VAC/400-575VAC/500-690VAC 3-phase
- Operational current: 22 - 1800Arms
- Keypad operation and LCD monitoring menu
- Adjustable Overcurrent "shearpin" protection
- Ramp-up and Ramp-down time settings up to 255sec
- In Delta compatibility
- Optional Modbus and Remote Keypad operation
- Automatic application setup
- Approvals: cULus (Up to 900Arms - RSQK40 and RSQK50 - V00 and V0F versions only)

Product Description

RSQK is a series of 3-phase controlled softstarters for 3-phase induction motors. Advanced features of the product include automatic application setup, energy optimising capability, keypad

programming, LCD monitoring menu and much more. The robust design of the product ensures that even applications with starting trip class 30 can be soft-started and softstopped.

Ordering Key **RSQ K 400 500 B 0 1V C F**

Q-Line Motor Controller
 Keypad operation _____
 Rated operational voltage _____
 Rated operational current _____
 Control voltage _____
 Housing _____
 Cooling Fans Voltage _____
 Options _____
 Communications Card ⁽¹⁾ _____
 Auxiliary Function Card _____

Type Selection

Type	Rated operational voltage U_e	Rated operational current I_e	Control voltage U_c
RSQK: Q-line motor controller with Keypad settings	40: (230-460VACrms)	0023: 23AACrms	B: 115 or 230VACrms *
	50: (400-575VACrms)	0030: 30AACrms	
	60: (500-690VACrms) ⁽¹⁾	0044: 44AACrms	
		0059: 59AACrms	
		0072: 72AACrms	
		0085: 85AACrms	
		0105: 105AACrms	
		0146: 146AACrms	
		0174: 174AACrms	
		0202: 202AACrms	
		0242: 242AACrms	
		0300: 300AACrms	
		0370: 370AACrms	
		0500: 500AACrms	
		0600: 600AACrms	
	0750: 750AACrms		
	0900: 900AACrms		
	1100: 1100AACrms ⁽¹⁾		
	1200: 1200AACrms ⁽¹⁾		
	1400: 1400AACrms ⁽¹⁾		
	1600: 1600AACrms ⁽¹⁾		
	1800: 1800AACrms ⁽¹⁾		

* To be supplied to terminals X1,X2 for internal control circuitry

Housing	Cooling Fans Voltage*	Options
0: IP00 ⁽¹⁾	0: No Fan selection required**	V00: Nil
1: IP20	1: 115VACrms	V0C: Communications Card ⁽¹⁾
	2: 230VACrms	V0F: Auxiliary Function Card
		V0C: Communications Card + Auxiliary function card ⁽¹⁾

* Cooling Fans are available from RSQK..0030B..V.. onwards.

** For RSQK..0400B0.V.. Up to RSQK..1800B0.V.. (i.e. IP00 versions),cooling fans are fixed voltage and must be specified as either 115V (Selection '1') or 230V (Selection '2')

⁽¹⁾: Not cULus approved

Note: Please see Type Selection Guide on next page.



Type Selection Guide

Type	Rated Operational Voltage	Rated Operational Current	Control Voltage	Housing	Cooling Fans Voltage	Options	
RSQK	40	22 - 382	B	1	0	V	00
	50						C0
	60						0F
							CF

Type	Rated Operational Voltage	Rated Operational Current	Control Voltage	Housing	Cooling Fans Voltage	Options	
RSQK	40	500 - 900	B	1	0	V	00
	50						C0
	60						0F
							CF

Type	Rated Operational Voltage	Rated Operational Current	Control Voltage	Housing	Cooling Fans Voltage	Options	
RSQK	40	500 - 900	B	0	1	V	00
	50				C0		
	60				0F		
					CF		

Type	Rated Operational Voltage	Rated Operational Current	Control Voltage	Housing	Cooling Fans Voltage	Options	
RSQK	40	1100 - 1800	B	0	1	V	00
	50				C0		
	60				0F		
					CF		

Selection Guide

In Line			In Delta		
le (A)	kW	HP	Motor Current	kW	HP
400V	400V	460V		400V	460V
23	11	15	39	19	25
30	15	20	51	25	34
44	22	30	76	38	51
59	30	42	102	51	72
72	37	54	124	64	93
85	45	60	147	77	103
105	55	75	181	95	129
146	75	106	252	129	183
174	90	150	301	155	259
202	110	175	349	190	303
242	132	200	419	228	346
300	160	250	519	277	363
370	200	270	640	346	381
400	220	300	692	381	433
500	250	360	866	433	519
600	320	400	1039	554	649
750	400	600	1299	692	935
900	500	750	1558	866	1160
1100	630	915	1905	1091	1299
1200	710	1000	2087	1229	1558
1400	850	1165	2424	1472	1905
1600	950	1250	2771	1645	2165
1800	1050	1400	3117	1818	2424

Trip Class	Trip Class	Trip Class	Trip Class
10B	10	20	30
RSQK..0023B10V..	RSQK..0023B10V..	RSQK..0030B1.V..	RSQK..0044B1.V..
RSQK..0030B1.V..	RSQK..0030B1.V..	RSQK..0044B1.V..	RSQK..0059B1.V..
RSQK..0044B1.V..	RSQK..0044B1.V..	RSQK..0059B1.V..	RSQK..0072B1.V..
RSQK..0059B1.V..	RSQK..0059B1.V..	RSQK..0072B1.V..	RSQK..0085B1.V..
RSQK..0072B1.V..	RSQK..0072B1.V..	RSQK..0085B1.V..	RSQK..0105B1.V..
RSQK..0085B1.V..	RSQK..0085B1.V..	RSQK..0105B1.V..	RSQK..0146B1.V..
RSQK..0105B1.V..	RSQK..0105B1.V..	RSQK..0146B1.V..	RSQK..0174B1.V..
RSQK..0146B1.V..	RSQK..0146B1.V..	RSQK..0174B1.V..	RSQK..0202B1.V..
RSQK..0174B1.V..	RSQK..0174B1.V..	RSQK..0202B1.V..	RSQK..0242B1.V..
RSQK..0202B1.V..	RSQK..0202B1.V..	RSQK..0242B1.V..	RSQK..0300B1.V..
RSQK..0242B1.V..	RSQK..0242B1.V..	RSQK..0300B1.V..	RSQK..0370B1.V..
RSQK..0300B1.V..	RSQK..0300B1.V..	RSQK..0370B1.V..	RSQK..0400B..V..
RSQK..0370B1.V..	RSQK..0370B1.V..	RSQK..0400B..V..	RSQK..0500B..V..
RSQK..0400B..V..	RSQK..0400B..V..	RSQK..0500B..V..	RSQK..0600B..V..
RSQK..0500B..V..	RSQK..0500B..V..	RSQK..0600B..V..	RSQK..0750B..V..
RSQK..0600B..V..	RSQK..0600B..V..	RSQK..0750B..V..	RSQK..0900B..V..
RSQK..0750B..V..	RSQK..0750B..V..	RSQK..0900B..V..	RSQK..1100B0.V..
RSQK..0900B..V..	RSQK..0900B..V..	RSQK..1100B0.V..	RSQK..1200B0.V..
RSQK..1100B0.V..	RSQK..1100B0.V..	RSQK..1200B0.V..	RSQK..1400B0.V..
RSQK..1200B0.V..	RSQK..1200B0.V..	RSQK..1400B0.V..	RSQK..1600B0.V..
RSQK..1400B0.V..	RSQK..1400B0.V..	RSQK..1600B0.V..	RSQK..1800B0.V..
RSQK..1600B0.V..	RSQK..1600B0.V..	RSQK..1800B0.V..	Note (1)
RSQK..1800B0.V..	RSQK..1800B0.V..	Note (1)	Note (1)

Note: Please refer to Product Selector Guide for further information on how to select the correct softstarter.

General Specifications

Ramp up time	1...255 sec
Ramp down time	0...255 sec
Parameter Selection	6 Button Keypad
Form Designation	Form 1
Integrated Overload Protection	Yes
Auxiliary Contacts (programmable relays)	
Run (11,12,14)	AC1 230VAC 3A
Top of Ramp (21,22,24)	AC1 230VAC 3A

Input Specifications

Control Supply (Us)	115V or 230VACrms
Control Supply (Uc) S0, S1	12V/24V DC or 115/230VAC
Rated AC frequency	50/60Hz +/- 10%
Rated Insulation Voltage (Ui)	690V

Supply Specifications

Operational voltage (Ue)	
RSQK40....	230 - 460 VACrms (-15% + 10%)
RSQK50....	400 - 575 VACrms (-15% + 10%)
RSQK60.... ⁽¹⁾	500 - 690 VACrms (-15% + 10%) ⁽¹⁾
Rated AC frequency	50 - 60 Hz +/- 2Hz

Output Specifications (Overload cycle according to EN/IEC 60947-4-2)

Product Code	Continuous/Optimising (AC53a)	Externally Bypassed (AC53b)
RSQK..0023B1 - RSQK..0085B1.	AC53a : 3-35:99-10 AC53a : 5-4:99-10	AC53b : 3-35:120 AC53b : 5-4:120
RSQK..0105B1 - RSQK..0202B1.	AC53a : 3-35:99-10 AC53a : 4-6:99-10	AC53b : 3-35:120 AC53b : 4-6:120
RSQK..0242B1 - RSQK..0900B1	AC53a : 3-35:60-3 AC53a : 4-6:60-3	AC53b : 3-35:360 AC53b : 4-6:360

Product Code	Continuous/Optimising (AC53a)
RSQK..0500B0 - RSQK..0600B0... / RSQK..0750B0	AC53a : 3-35:60-6
RSQK..0900B0 / RSQK..1100B0 ⁽¹⁾ / RSQK..1200B0 ⁽¹⁾	AC53a : 5-4:60-6
RSQK..1400B0 - RSQK..1800B0 ⁽¹⁾	AC53a : 3-30:60-3 AC53a : 5-4:60-3

⁽¹⁾. Not cULus approved

Dimensions - IP20 Housing (RSQK.....B1....)

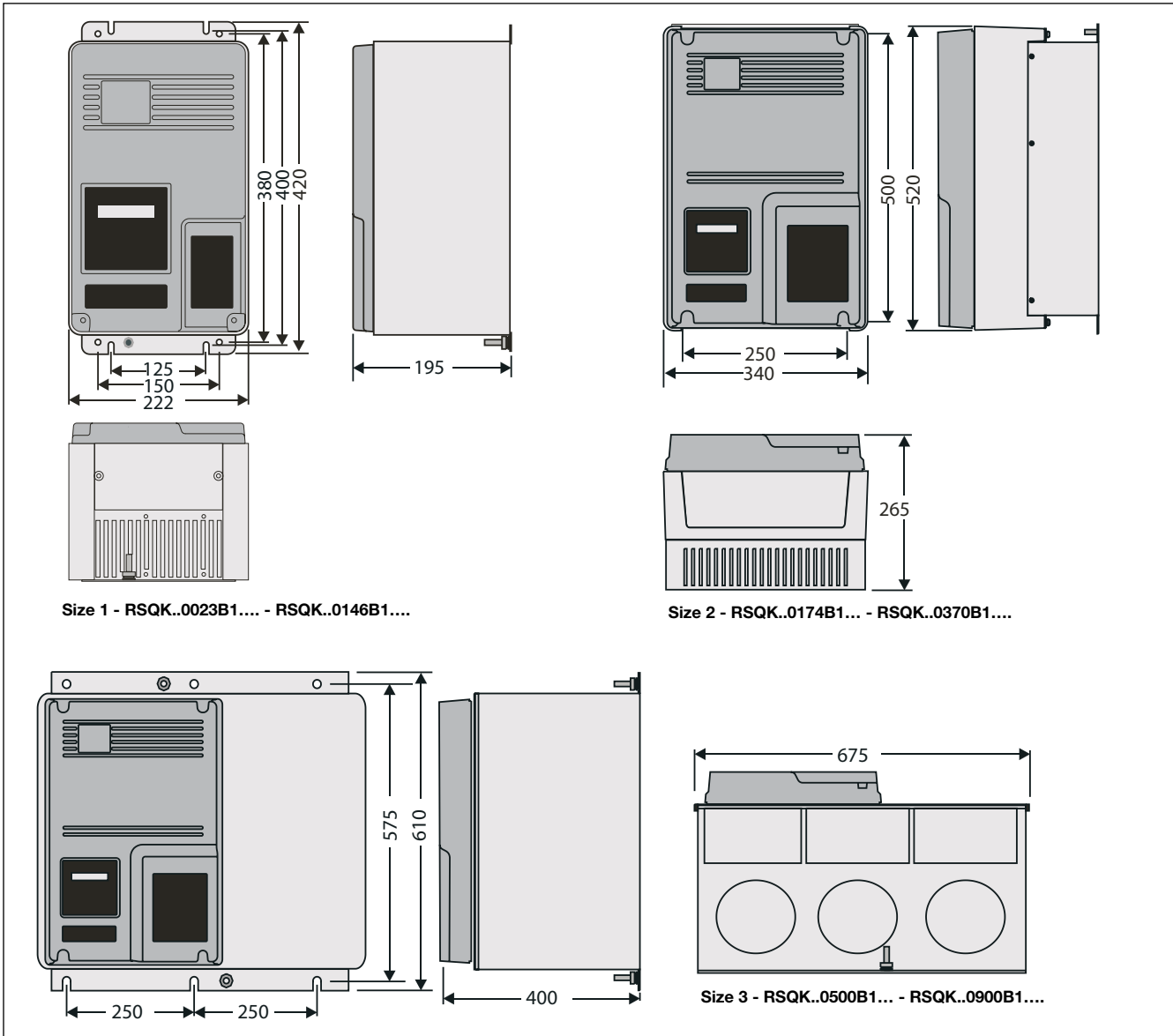

Dimensions	Width (W)	Height (H)	Depth (D)	Unit Cooling Method	Mounting Clearance		
					Side	Top & Bottom	Front
RSQK..0023B10V..	222	420	195	Natural Convection			
RSQK..0030B10V.. To RSQK..0146B10V..	222	420	195	Forced-air with built in fan	15	75	25
RSQK..0174B10V.. To RSQK..0370B10V..	340	500	265				
RSQK..0500B10V.. To RSQK..0900B10V..	675	610	400		200*	200	25

All dimensions in mm

* When fitting the unit into a cabinet, allowance must be made for 90°C opening of the hinged unit doors. Add 90mm for the left-hand door which has the plastic moulding incorporating the control card and keypad, and 30mm for the right hand door (i.e. 90 + 675 + 30 = 795mm as an overall cabinet opening)

Note: When fitting a RSQK into a cabinet, ventilation must be provided if the heat output of the unit is greater than the cabinet will dissipate. Use the following formula to determine the fan requirement. An allowance has been incorporated in the formula so that the figure for Q is the air delivery quoted in the fan suppliers data. An approximation of the heat produced by the RSQK (in Watts) is available in the table hereunder.

$$Q = \frac{4xWt}{(t_{max} - t_{amb})}$$

Q - required volume of air (cubic metres per hour [m³/h])

Wt - heat produced by the unit and all other heat sources within the enclosure (Watts)

t_{max} - maximum permissible temperature within the enclosure (40°C for a fully rated RSQK)

t_{amb} - temperature of the air entering the enclosure (°C)

Heat Output of RSQK Units*

Housing Size 1		Housing Size 2		Housing Size 3	
Product Code	Heat Output (W)	Product Code	Heat Output (W)	Product Code	Heat Output (W)
RSQK..0023B1...	60	RSQK..0174B1...	520	RSQK..0500B1...	1600
RSQK..0030B1...	90	RSQK..0202B1...	610	RSQK..0600B1...	2000
RSQK..0044B1...	120	RSQK..0242B1...	650	RSQK..0750B1...	2500
RSQK..0059B1...	155	RSQK..0300B1...	850	RSQK..0900B1...	3000
RSQK..0072B1...	210	RSQK..0370B1...	970		
RSQK..0085B1...	220				
RSQK..0105B1...	275				
RSQK..0146B1...	440				

* At rated operational current I_e, Unit Full load current (FLC)

Dimensions - IP00 Housing (RSQK.....B0....) (1)

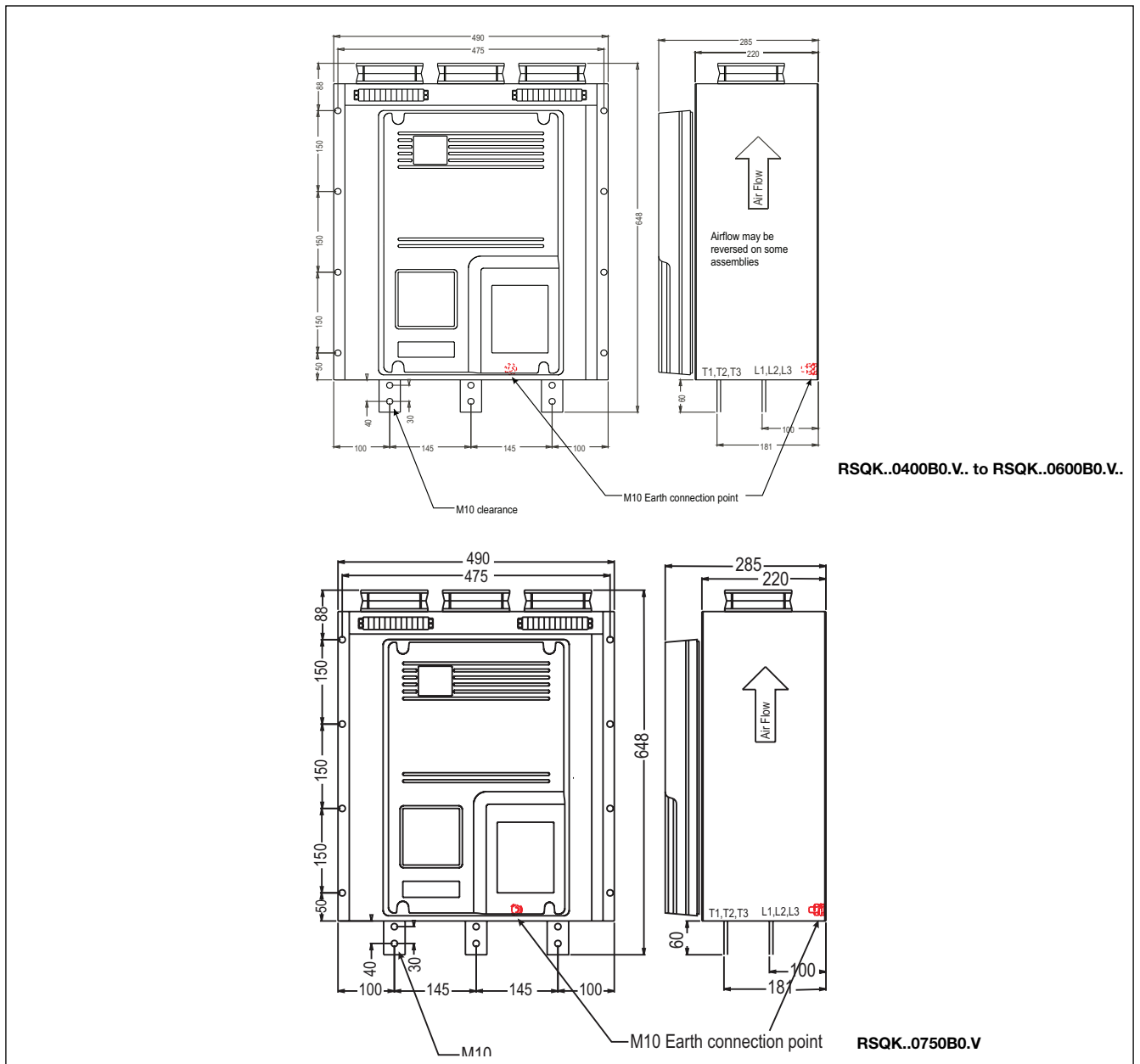

(1). Not cULus approved

Dimensions - IP00 Housing (RSQK.....B0....) cont... (1)

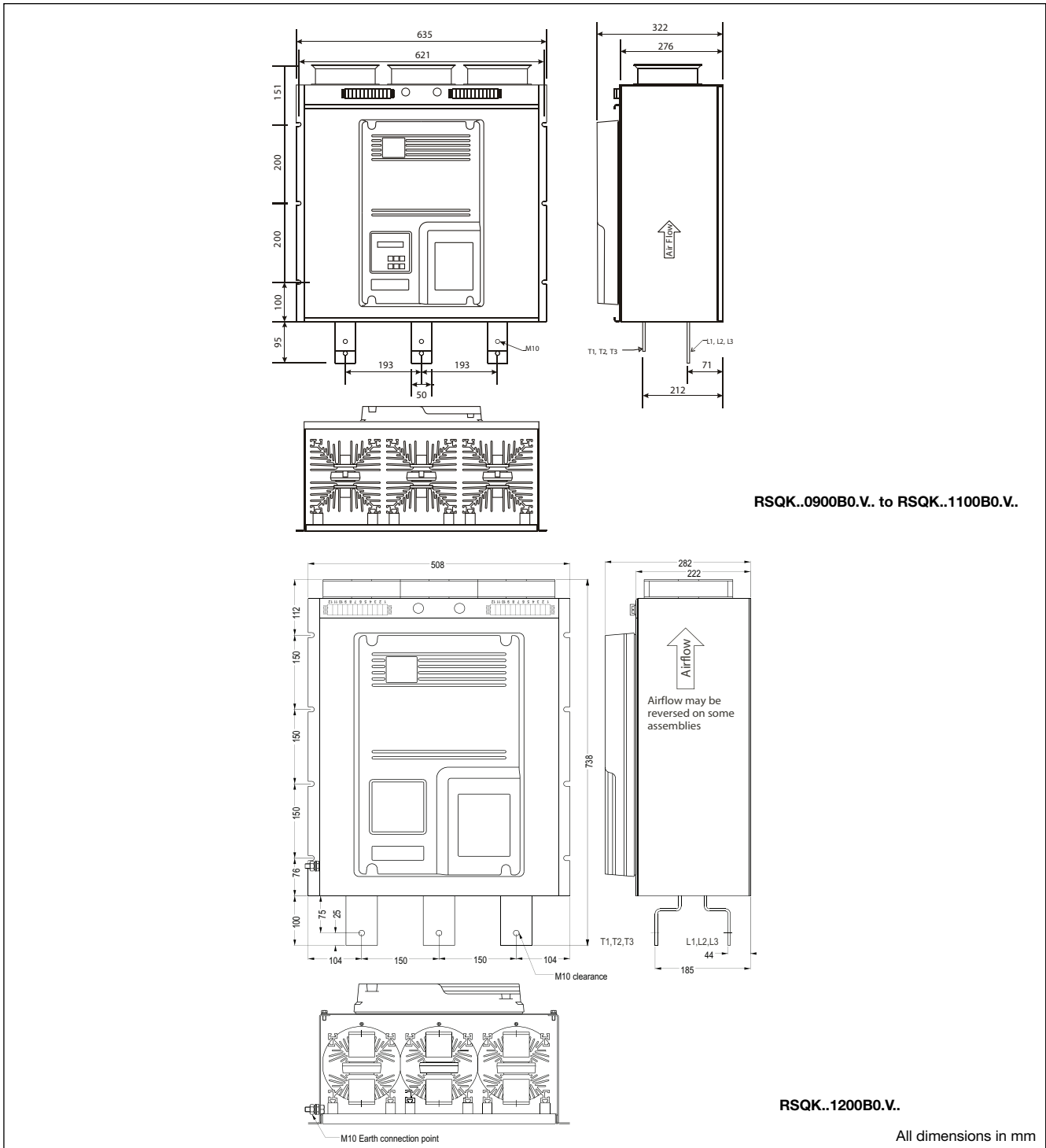

Note: Fans for RSQK..0400B0.V. Up to RSQK..0750B0.v.. are fixed voltage and must be specified as either 115V or 230V (refer to Ordering Key section)

Dimensions	Width (W)	Height (H)	Depth (D)	Unit Cooling Method	Mounting Clearance		
					Side	Top & Bottom	Front
RSQK..0400B0.V. To RSQK..0600B0.V. (1)	490	648	285	Forced-air with built in fan	25	200	25
RSQK..0750B0.V. (1)	508	738	282				
RSQK..0900B0.V. To RSQK..1100B0.V. (1)	635	746	322				
RSQK..1200B0V. (1)	635	782	322				
RSQK..1400B0V. To RSQK..1800B0V. (1)	770	775	475				



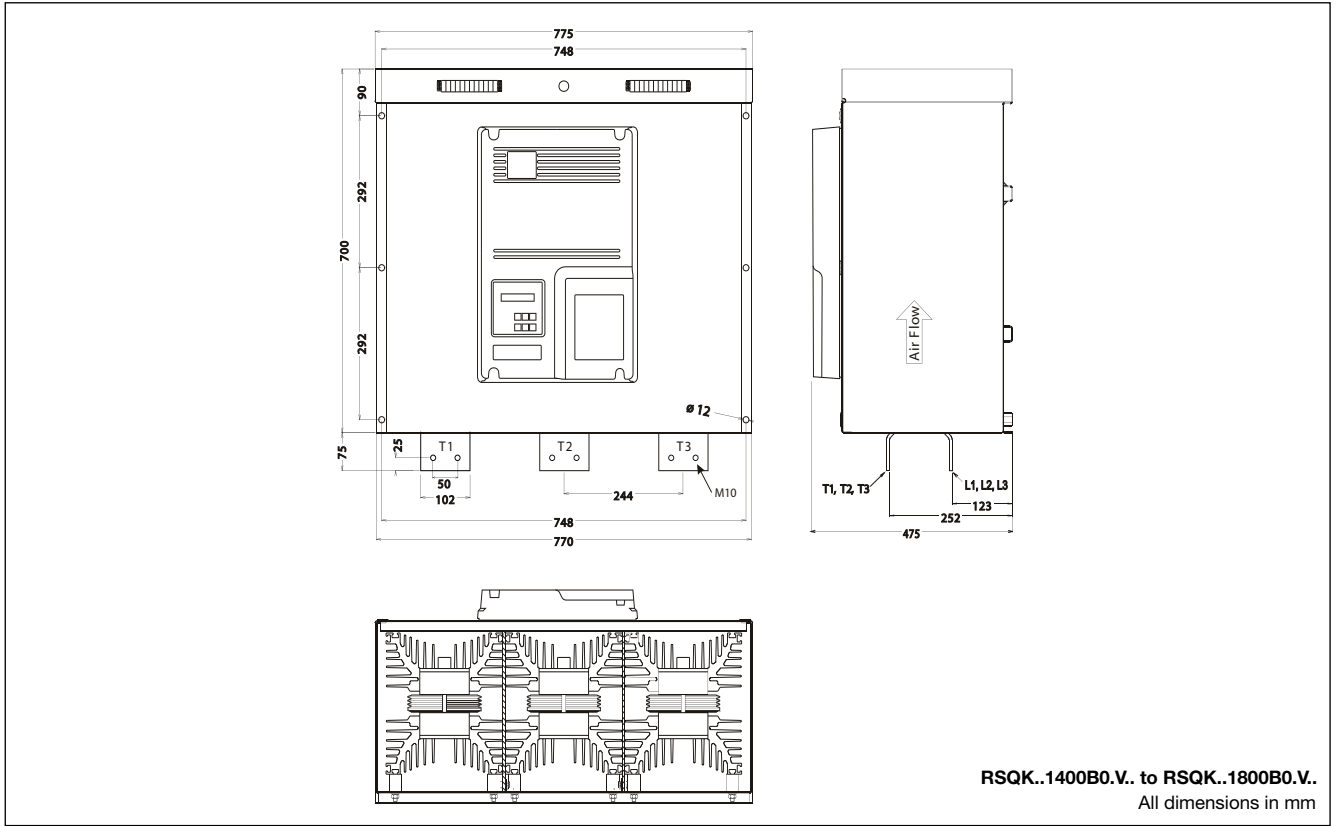

(1). Not cULus approved

All dimensions in mm

Dimensions - IP00 Housing (RSQK.....B0....) cont... (1)







Conductor Data

size1: RSQK..0023B1.V. to RSQK..0146B1.V..		Terminal Type	Conductor Type	Cable Cross Section *		Terminal Tightening Torque	
				AWG	mm ²		
Power	L1, L2, L3, T1, T2, T3	M8 metric threaded studs	Use 75°C copper (Cu) conductor only.	1/0	50	106 lb.in. (12 Nm)	
Ground	PE 	M8 metric threaded studs	Wire shall be fitted with close eyelet lug.				
size2: RSQK..0174B1.V. to RSQK..0370B1.V..		Terminal Type	Conductor Type	Cable Cross Section *		Busbar size (mm)*	Terminal tightening torque
				AWG	mm ²		
Power	L1, L2, L3, T1, T2, T3	M8 metric threaded studs	Use 75°C copper (Cu) conductor only.	2 x 250MCM	2 x 120	20 x 6	106 lb.in. (12 Nm)
Ground	PE 	M8 metric threaded studs	Wire shall be fitted with close eyelet lug.				
size3: RSQK..0500B1.V. to RSQK..0900B1.V..		Terminal Type	Conductor Type	Busbar size (mm)*		Terminal Tightening Torque	
Power	L1, L2, L3, T1, T2, T3	2 x M10 nuts and bolts	Use busbar	45 x 20 60 x 10 80 x 10		212 lb. in. (24 Nm)	
Ground	PE 	M10 metric threaded studs					
RSQK..0400B0.V. ¹ to RSQK..0600B1.V. ¹		Terminal Type	Conductor Type	Busbar size (mm)*		Terminal Tightening Torque	
Power	L1, L2, L3, T1, T2, T3	2 x M10 nuts and bolts	Use busbar	520Amp: 25 x 10, 40 x 5 562Amp: 25 x 12, 40 x 6 662Amp: 40 x 8, 50 x 5		46Nm (34 lb-ft)	
Ground	PE 	M8 metric threaded studs				23Nm (17 lb-ft)	

(1). Not cULus approved

Conductor Data (cont.)

<i>RSQK..0750B0.V..(1)</i>		Terminal Type	Conductor Type	Busbar size (mm)*	Terminal Tightening Torque			
Power	L1, L2, L3, T1, T2, T3	1 x M12 nuts and bolts	Use busbar	817Amp: 40 x 10, 50 x 8	79Nm (58 lb-ft)			
Ground	PE 	M10 metric threaded studs			46Nm (34 lb-ft)			
<i>RSQK..0900B0.V..(1)</i> to <i>RSQK..1100B0.V..(1)</i>		Terminal Type	Conductor Type	Busbar size (mm)*	Terminal Tightening Torque			
Power	L1, L2, L3, T1, T2, T3	1 x M12 nuts and bolts	Use busbar	895Amp: 50 x 10, 60 x 8 1000Amp: 50 x 12, 60 x 8 1115Amp: 50 x 16, 60 x 10	79Nm (58 lb-ft)			
Ground	PE 	M10 metric threaded studs			46Nm (34 lb-ft)			
<i>RSQK..1200B0.V.. 1</i>		Terminal Type	Conductor Type	Busbar size (mm)*	Terminal Tightening Torque			
Power	L1, L2, L3, T1, T2, T3	1 x M12 nuts and bolts	Use busbar	1210Amp: 60 x 12	79Nm (58 lb-ft)			
Ground	PE 	M10 metric threaded studs			46Nm (34 lb-ft)			
<i>RSQK..1400B0.V..(1)</i> to <i>RSQK..1800B0.V..(1)</i>		Terminal Type	Conductor Type	Busbar size (mm)*	Terminal Tightening Torque			
Power	L1, L2, L3, T1, T2, T3	2 x M12 nuts and bolts	Use busbar	1420Amp: 80 x 8, 100 x 5 1580Amp: 80 x 10, 100 x 6 1810Amp: 80 x 12, 100 x 10	79Nm (58 lb-ft)			
Ground	PE 	M12 metric threaded studs			79Nm (34 lb-ft)			
All models Secondary conductors		Terminal Type	Wire Type	Cable Cross Section *		Terminal Tightening Torque		
		Screw clamp Terminals	Solid or Stranded	AWG		mm ²		
				min.	max.	min.	max.	
X1, X2 S0, S1 11, 12, 14, 21, 22, 24				22	14	0.3	2.5	4.4 lb.in. (0.5 Nm)

* The conductor sizes indicated in the above table are the maximum allowed for each chassis size. The actual conductor used must comply with local wiring regulations.

Note: To maintain approvals for cable connections, the wire terminals should conform to local regulations and be fitted using specified crimping tools as indicated by the manufacturer.

Environmental Specifications

Ambient temperature	0°C to 40°C (32°F to 104°F) Above 40°C de-rate linearly by 2% of unit FLC per °C to a derate of 40% at 60°C.	Degree of Protection	IP00: <i>RSQK..0500B0.V..(1)</i> to <i>RSQK..1800B0.V..(1)</i> IP20: <i>RSQK..0023B1.V..</i> to <i>RSQK..0900B1.V..</i>
Transport and Storage temperature		Installation altitude	1000m. Above 1000m de-rate linearly by 1% FLC per 100m to a maximum altitude of 2000m
Continuous Not exceeding 24 hrs	-25°C to +60°C (-13°F to 140°F) -25°C to +75°C (-13°F to 167°F)	Pollution Degree	3
Relative Humidity	<85% non-condensing, not exceeding 50% @ 40°C		

(1). Not cULus approved

Wiring Diagrams

In Line Connection of Motors (Note 1)

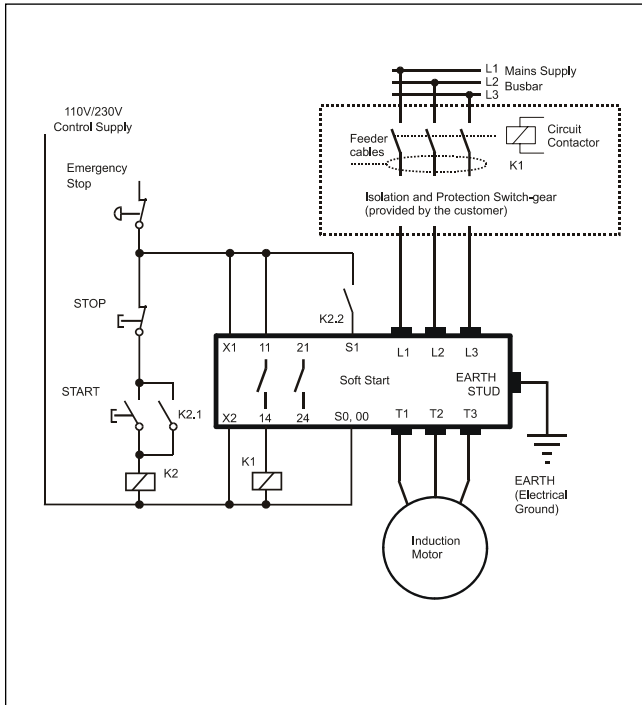

Note 1: The in-line configuration shown above requires that the firing mode be set to '0'.

In Delta Connection of Motors (Note 2)

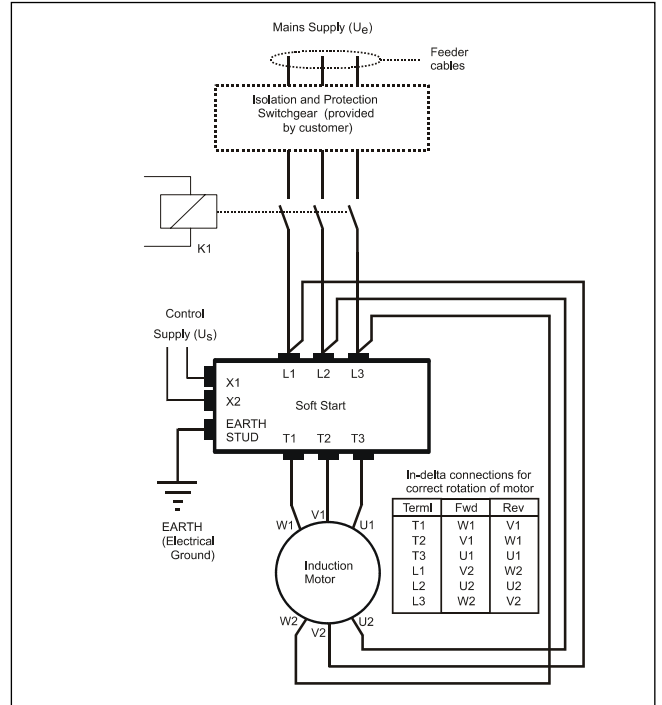

Note 2: The In-Delta configuration requires that the firing mode be set to '1'. An in-line contactor controlled by the RSXK MUST be used in the In-Delta firing mode.

Connection for bypass operation (Note 3)

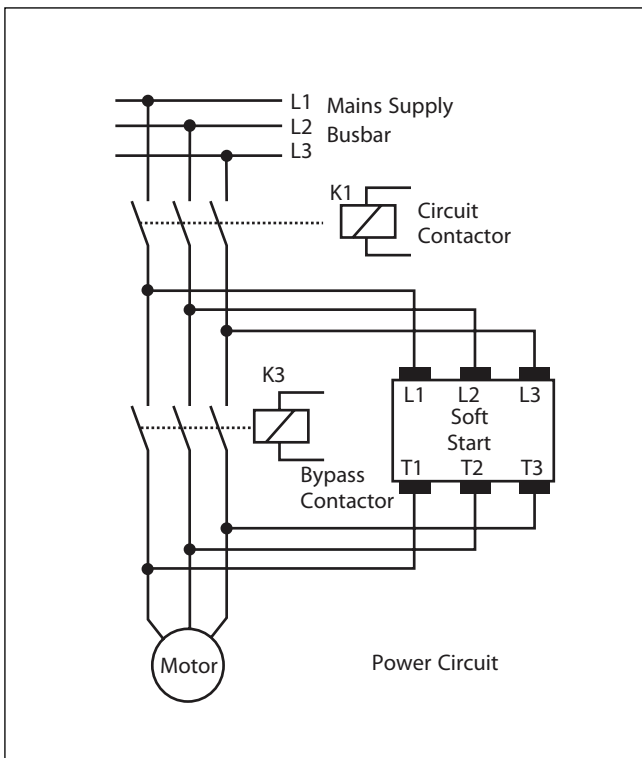

Note 3: The bypass configuration is automatically detected as "Auto Bypass" is set as default.

Control Circuit Wiring (Note 4)

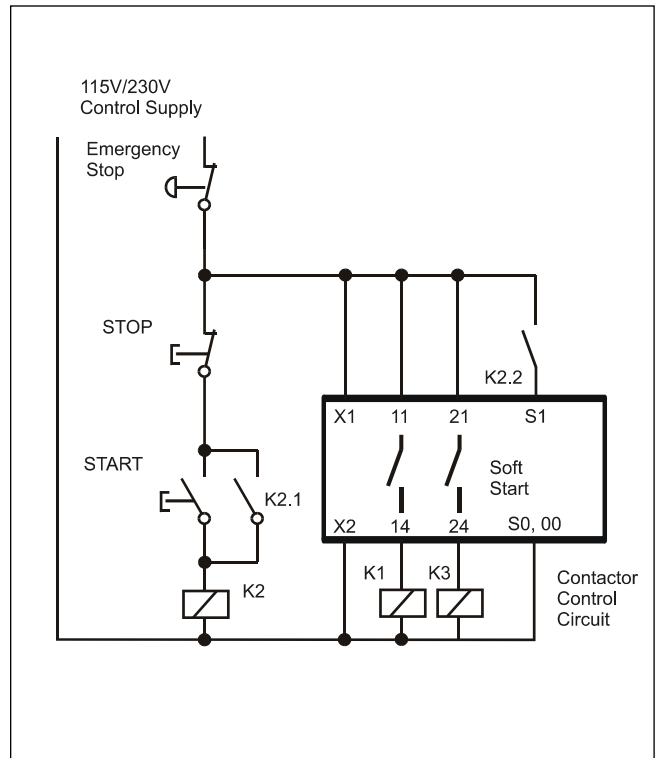

Note 4: Contactor K3 is required for the 'operation in Bypass Power Circuit' and is controlled by the programmable relay set as 'Top of Ramp' relay.

Terminal Diagram

Applicable to RSQK..0023B1.V.. up to RSQK..0370B1.V..

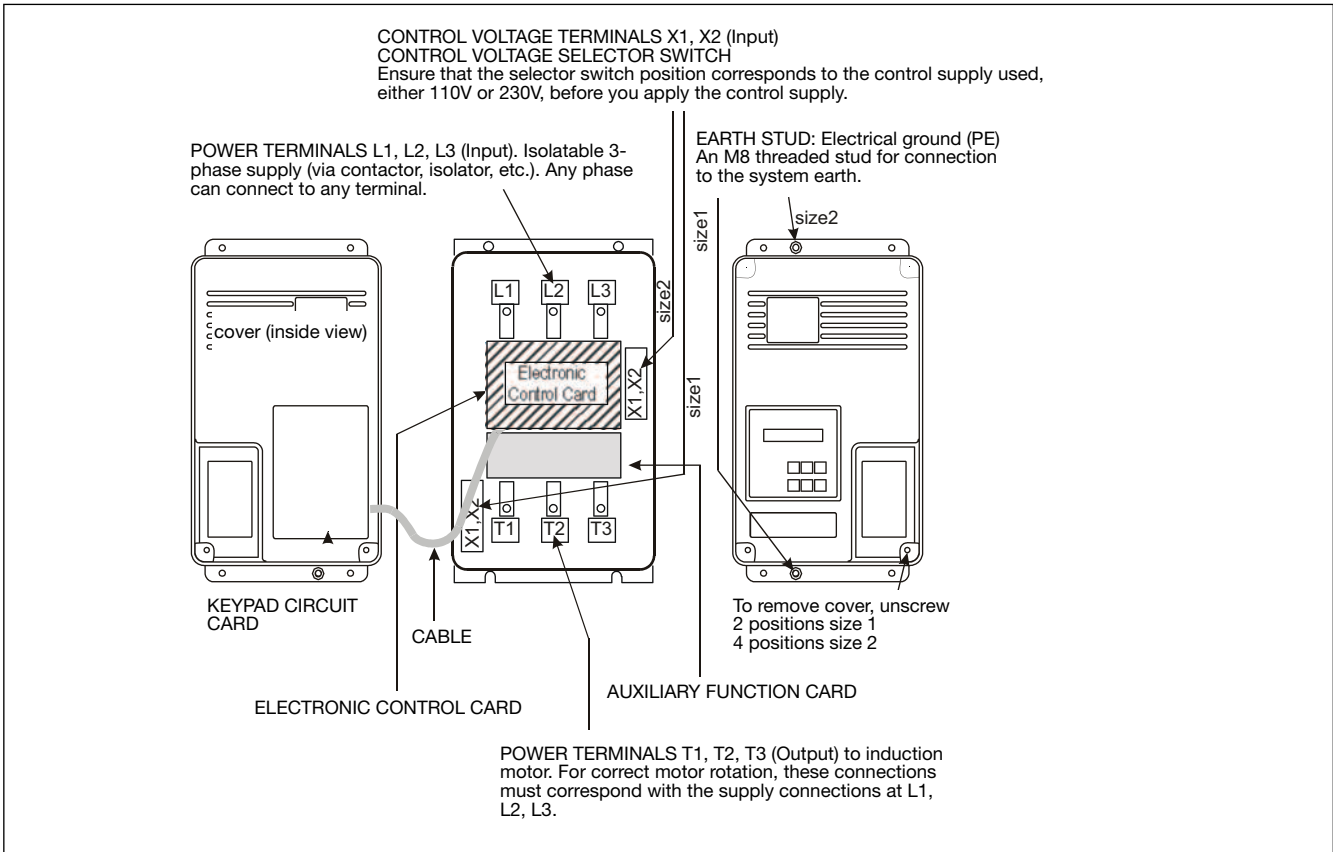

Applicable for RSQK..0500B0.V.. up to RSXK..0900B1.V..

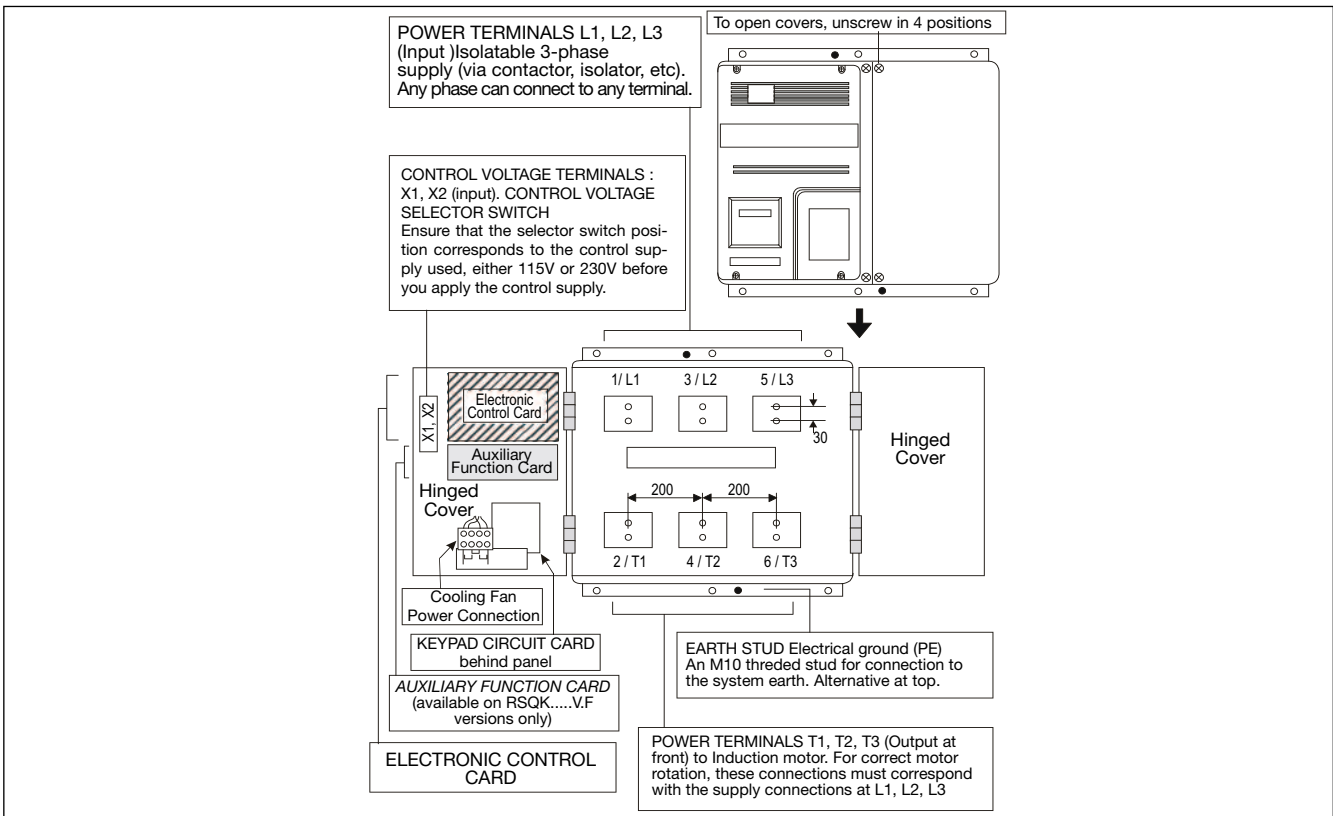

Applicable for RSQK..0500B0.V. up to RSQK..1800B0.V. (1)

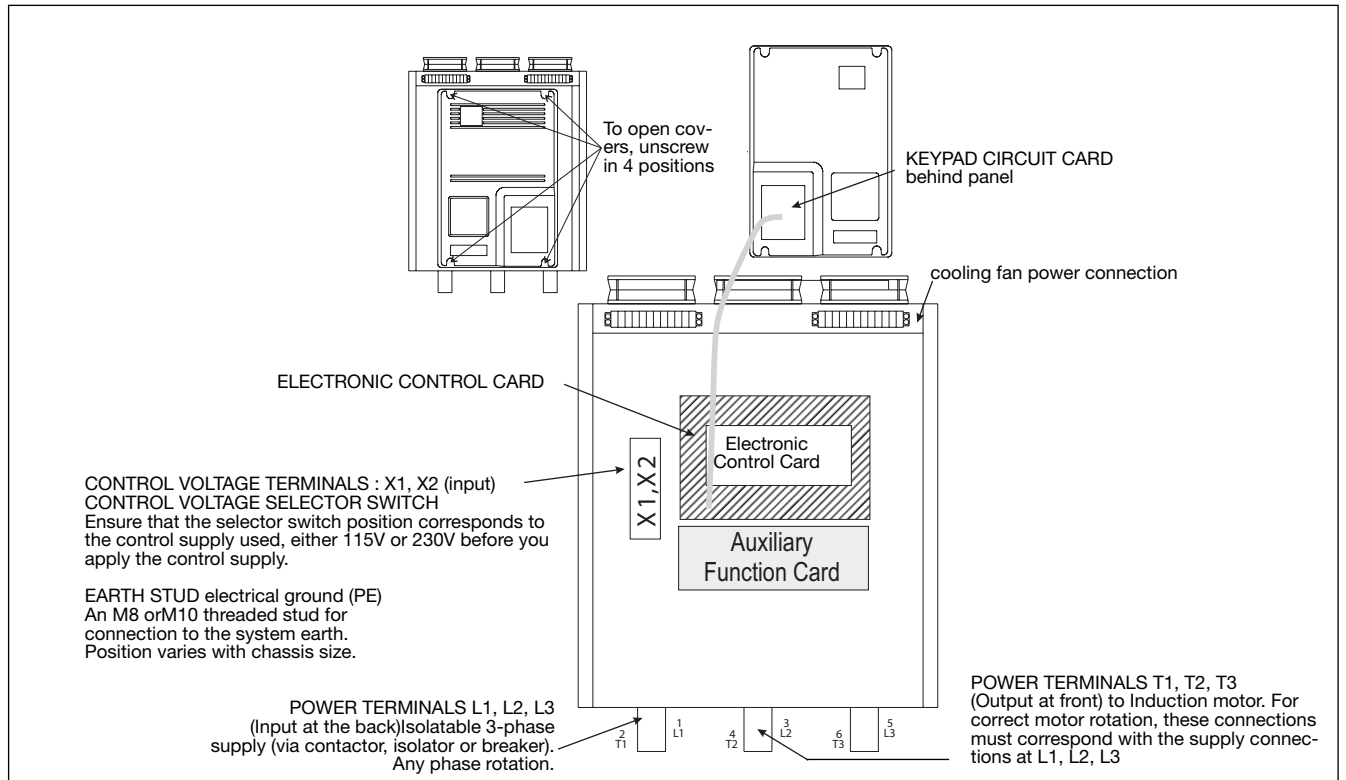

Electronic Control Card Connection

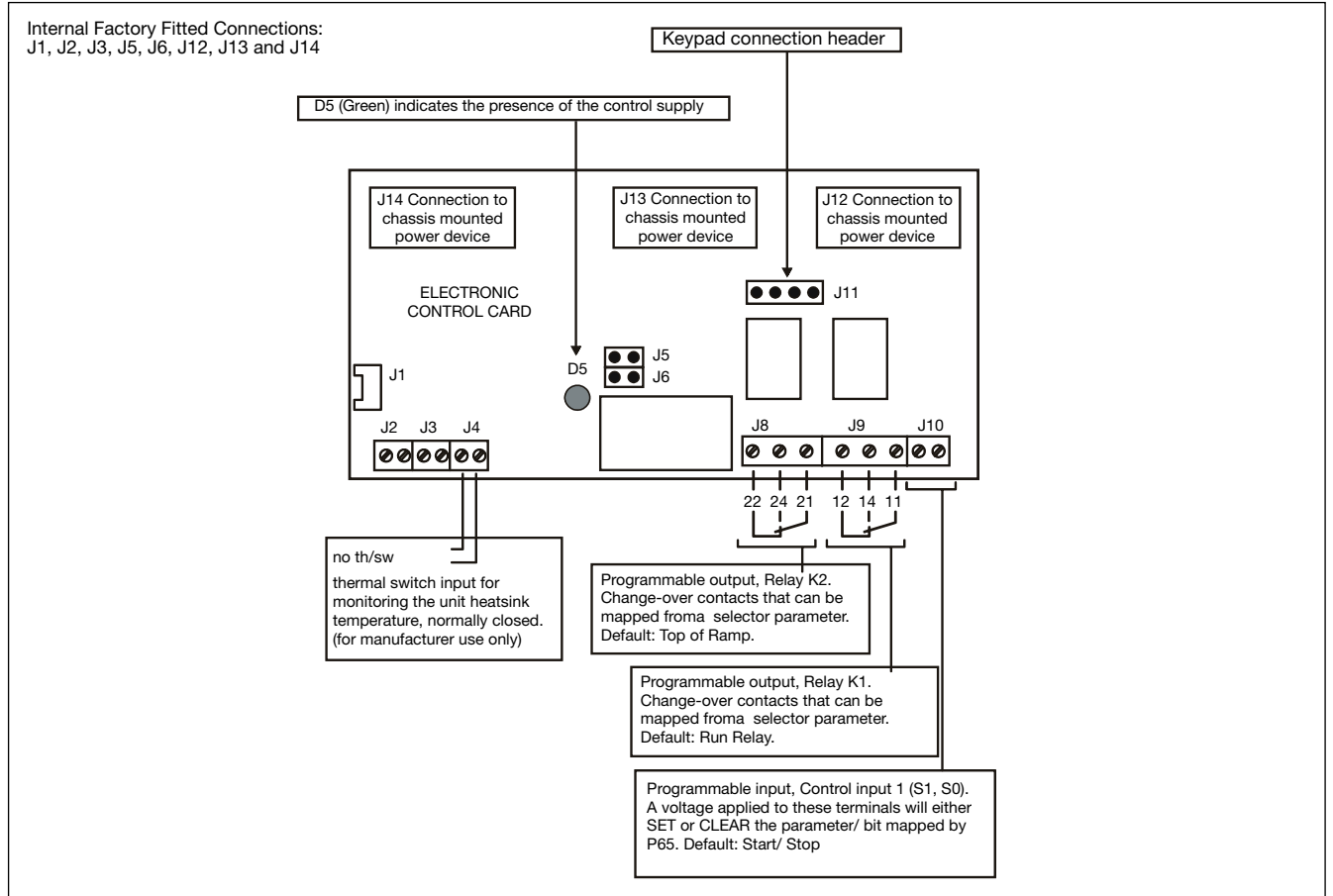

(1). Not cULus approved

Standards

UL, cUL Listed	E172877 (Up to 900Arms - RSQK40 and RSQK50 - V00 and V0F versions only)	Conducted Radio Frequency Immunity	IEC/EN 61000-4-6 140db μ V, 0.15-80MHz
CE Marking LVD	IEC/EN 60947-4-2	Radio Interference field emission (radiated)	IEC/EN 55011, Class A
Electrostatic Discharge (ESD) Immunity	IEC/EN 61000-4-2 8kV, Contact 6kV, Air discharge	Radio Interference voltage emission (conducted)	IEC/EN 55011, Class A
Electrical Fast Transient Burst Immunity	IEC/EN 61000-4-4 Output 2kV/5kHz Input 2kV/5kHz	Electrical Surge Immunity	IEC/EN 61000-4-5 Output, line to line 1kV Output, line to earth 2kV Input, line to line 1kV Input, line to earth 2kV
		Radiated Radio Frequency Immunity	IEC/EN 61000-4-3 10V/m, 80 - 1000 Mhz

Alarms

Fault Code		Explanation
1	Phase Loss	Input side phase loss at the ramp start, during ramp or during normal running.
2	Too Hot	The heatsink is above the maximum allowed temperature or input open circuit.
3	Comms	There have been a number of serial communication errors but communications are still active.
4	SCR Firing	Short circuit thyristor during normal running.
5	SCR Signal	Short circuit thyristor during normal running or Motor side phase loss during the ramp or during normal running.
6	SCR Signal	Input side phase loss during normal running. Short circuit thyristor or motor side phase loss during the ramp or during normal running.
7	Sensing Signal	Short circuit thyristor, external noise or motor side phase loss during the ramp or during normal running.
8	Motor, SCR Loss	Short circuit thyristor or motor side phase loss at the start of the ramp.
9	Sensing Signal	Short circuit thyristor, external noise or motor side phase loss during the ramp or during normal running.
10	SCR Shorted	Short circuit thyristor or motor side phase loss during the ramp.
11	Low Current	Current has fallen below the under-current level. (Only active during normal running)
12	C/L Time Out	Current limit during the ramp has exceeded the current limit time-out period.
13	Overload	Current has exceeded the overload level. (Active at all stages of operation)
14	Shearpin	Current has exceeded the shearpin current level. (Only active during normal running)
15	Thermistor	Thermistor input is open circuit or thermistor resistance has exceeded its trip point.
16	User	A trip input from the user to the soft starter.
17	Comms Timeout	Serial communications have been lost.
18	Bypass failed	Bypass contactor failed to close on AC53b unit.
Stopped Cooling		Displayed during the period for which the soft starter will not restart to allow heatsink cooling.

Overload Trip Curves

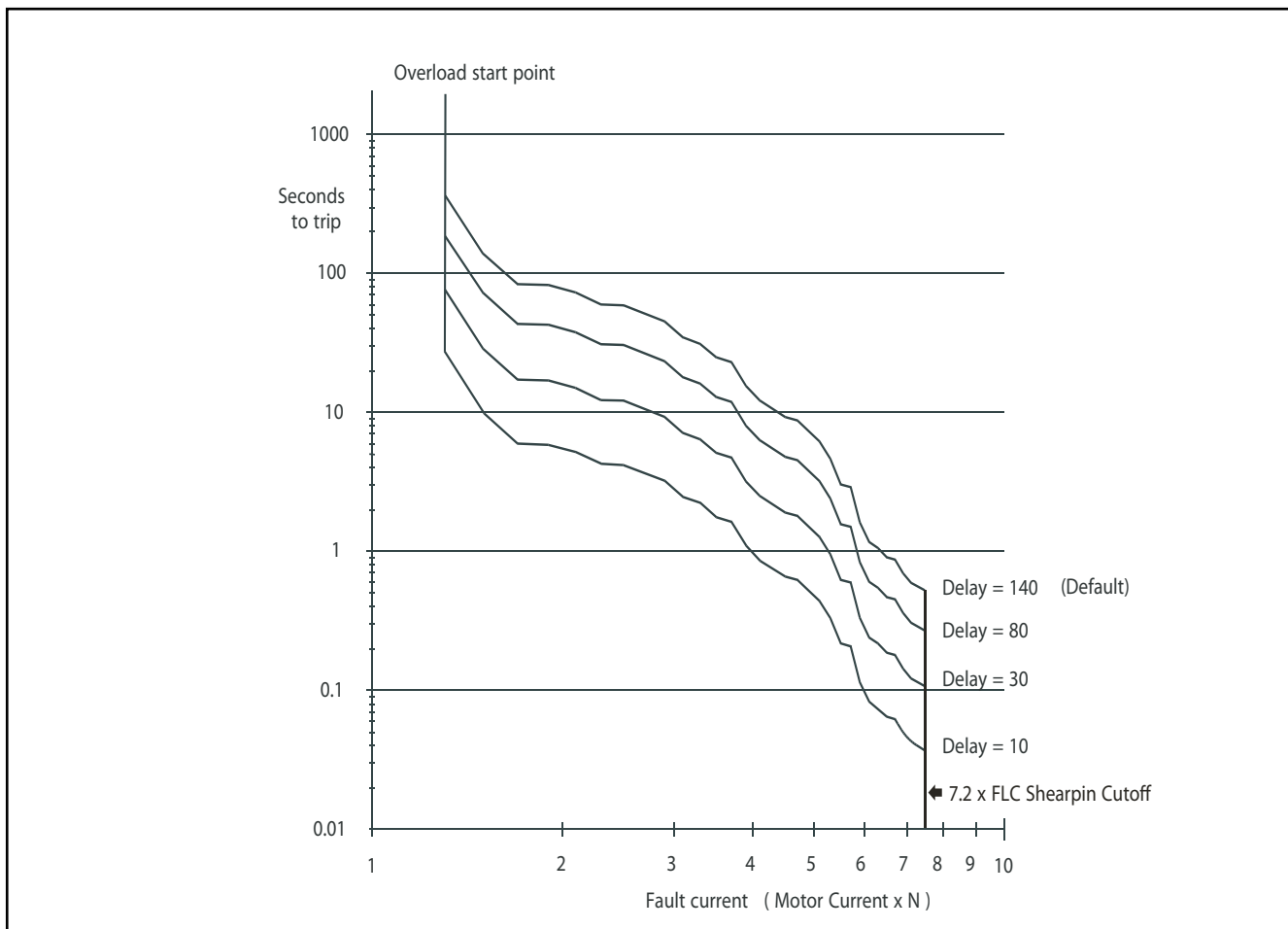

Current Limit, 'Overload level' and 'Overload delay' settings may be adjusted to limit overload currents in accordance with the trip curves shown here. For motors with FLC's lower than the rated current of the RSQK, the 'Overload Level' may be adjusted using the following formula: $\text{Overload level} = \text{Motor FLC} \times 1.1 (A)$

Note: The overload monitors one of the phases only and the 'Current Limit' level is only active during motor starting. It is recommended that the control supply is maintained between starts to ensure the integrity of the overload, which will reset on its removal.

Short Circuit Protection

Type of coordination: 1

Semiconductor Fuse Types

Product Code	I _e (Arms)	Short circuit Amp RMS (kA)	UL Recognised JFHR2 fuses		Amps
			Bussmann Int. No.	Ferraz Mod. No.	
RSQK..0023B1.V..	23	5	170M3112	6.6URD 30 D08A 0100	100
RSQK..0030B1.V..	30	5	170M3112	6.6URD 30 D08A 0100	100
RSQK..0044B1.V..	44	5	170M3114	6.6URD 30 D08A 0160	160
RSQK..0059B1.V..	59	5	170M3115	6.6URD 30 D08A 0200	200
RSQK..0072B1.V..	72	10	170M3116	6.6URD 30 D08A 0250	250
RSQK..0085B1.V..	85	10	170M3116	6.6URD 30 D08A 0250	250
RSQK..0105B1.V..	105	10	170M3119	6.6URD 30 D08A 0400	400
RSQK..0146B1.V..	146	10	170M3119	6.6URD 30 D08A 0400	400
RSQK..0174B1.V..	174	10	170M3121	6.6URD 30 D08A 0500	500
RSQK..0202B1.V..	202	10	170M3121	6.6URD 30 D08A 0500	500
RSQK..0242B1.V..	242	10	170M4114	6.6URD 30 D08A 0500	500
RSQK..0300B1.V..	300	18	170M4114	6.6URD 30 D08A 0500	500
RSQK..0370B1.V..	370	18	170M4116	6.6URD 30 D08A 0630	630
RSQK..0500B1.V..	500	18	170M6113	6.6URD 30 D08A 0900	900
RSQK..0600B1.V..	600	30	170M6113	6.6URD 30 D08A 0900	900
RSQK..0750B1.V..	750	30	170M6116	6.6URD 30 D08A 1250	1250
RSQK..0900B1.V..	900	42	170M6116	6.6URD 30 D08A 1250	1250

UL requires recognised special purpose fuses (JFHR2) for the protection of semiconductor devices, rated 700Vac, as indicated in the above table, can be used to obtain the short circuit ratings required by UL. Suitable for use on a circuit capable of delivering not more than the RMS Symmetrical Amperes indicated in the above table at maximum rated operational voltage, when protected by Semiconductor Fuse Type, Manufactured by Company and Mod. No. indicated in the above table. Fuse rated 700Vac, Amps as indicated in the above table.

These fuses are for short circuit protection of the semiconductors and must be mounted externally by the user between the unit and the mains supply, not between the unit and the motor.

Product Code	I _e (Arms)	Short circuit Amp RMS (kA)	Fuse Details		Amps
			Bussmann Int. No.	SIBA Mod. No.	
RSQK..0500B0.V..	500	18	170M5466	2067132.1000A	1000
RSQK..0600B0.V..	600	30	170M5466	2067132.1000A	1000
RSQK..0750B0.V.,	750	30	170M6466	2068132.1250A	1250
RSQK..0900B0.V..	900	42	170M6466	2068132.1250A	1250
RSQK..1100B0.V.. (1)	1100	85	170M6467	2068132.1400A	1400
RSQK..1200B0.V.. (1)	1200	85	2x170M6466 in parallel per phase		2000
RSQK..1400B0.V.. (1)	1400	85	2x170M6466 in parallel per phase		2500
RSQK..1600B0.V.. (1)	1600	85	2x170M6471 in parallel per phase*		4000
RSQK..1800B0.V.. (1)	1800	100	2x170M6471 in parallel per phase*		4000

* Note: Limits rated operational voltage to 500VAC.

(1): Not cULus approved



Typical Motor Powers at rated voltages

RSQK..XXXXB.V..	Amps	208Volts		230Volts		400Volts		460Volts		575Volts ⁽¹⁾		690Volts ⁽¹⁾	
		kW	HP	kW	HP	kW	HP	kW	HP	kW	HP	kW	HP
0023	23	3.75	5	6.3	8.5	11	15	11	15	15	20	22	30
0030	30	5.5	7.5	7.5	10	15	20	15	20	18.5	25	30	40
0044	44	7.5	10	11	15	22	30	22	30	30	40	37	50
0059	59	11	15	16	22	30	40	32	42	37	50	55	75
0072	72	15	21	20	27	37	50	40	54	45	60	60	80
0085	85	18.5	25	22	30	45	60	45	60	55	75	75	100
0105	105	22	30	30	40	55	75	55	75	75	100	90	120
0146	146	37	50	45	60	75	100	80	106	110	150	132	175
0174	174	45	60	55	75	90	120	110	150	132	175	160	220
0202	202	45	60	63	85	110	150	132	175	150	200	200	270
0242	242	55	75	75	100	132	175	150	200	185	250	220	300
0300	300	75	100	90	120	160	220	185	250	220	300	250	350
0370	370	90	125	110	150	200	270	220	300	250	350	355	470
0500	500	110	150	160	220	250	350	300	400	375	500	500	670
0600	600	150	200	185	250	320	400	375	500	450	600	560	750
0750	750	210	280	250	350	400	540	450	600	560	750	710	940
0900	900	255	340	300	400	500	670	560	750	670	900	900	1200
1100 ⁽¹⁾	1100	312	415	340	455	615	820	685	915	855	1140	1100	1465
1200 ⁽¹⁾	1200	340	455	375	500	670	895	750	1000	935	1250	1200	1600
1400 ⁽¹⁾	1400	395	530	435	580	780	1045	875	1165	1090	1455	1400	1865
1600 ⁽¹⁾	1600	450	605	500	665	895	1190	1000	1330	1250	1665	1600	2130

The currents listed in the above table are for 3-phase, 4-pole motors operating on 50/60Hz supplies. Actual currents of motors may vary by +/- 10% depending on size and manufacturer. Motors of lower speeds generally draw higher currents for the same rated output. Typically +10% for 6-pole or +20% for 8-pole compared to 4 pole motors.

Accessories

Keypod



- Ordering Code: MMRK
- Can be used on a one to one basis, or one Keypod can control several Soft Starters
- Seven buttons with individual Start and stop
- Display via a 2 line 32 character LED
- Eliminates panel mounted Start and Stop push buttons, Ammeters, Run, Top of Ramp and Alarm Lamps
- The Keypod gives continuous display of motor phase current and control status, Starting, Stopping, Full Volts, Optimising, Current Limitation, Overload and Fault Indication

Communications Card (Modbus) (1)

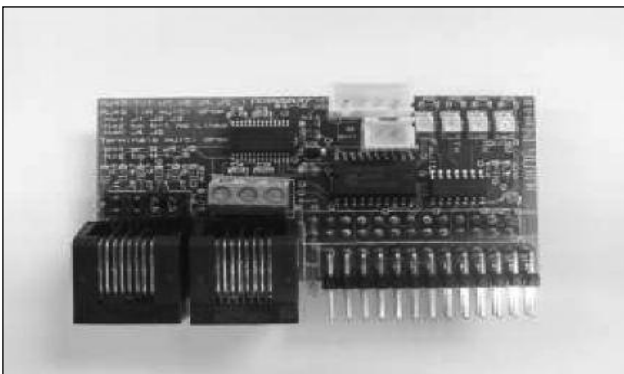

AP9A00 circuit board

- Ordering Code: MMKC or Option VC. (refer to RSQK ordering code)
- Enables the set up, control and monitoring of single or multiple RSQK softstarters
- RS485 interface with 50V isolation for demanding industrial applications
- Interface is suitable for connection to the remote keypod or a standard Modbus network running at 9600 baud 8N1.
- Connection via standard CAT5 RJ45 terminated ethernet cable
- Onboard RJ45 connector for multiple softstarter connection
- Standard twisted pair wiring may also be used via the secondary screw terminals

Connection of multiple RSQK softstarters via RJ45 connectors

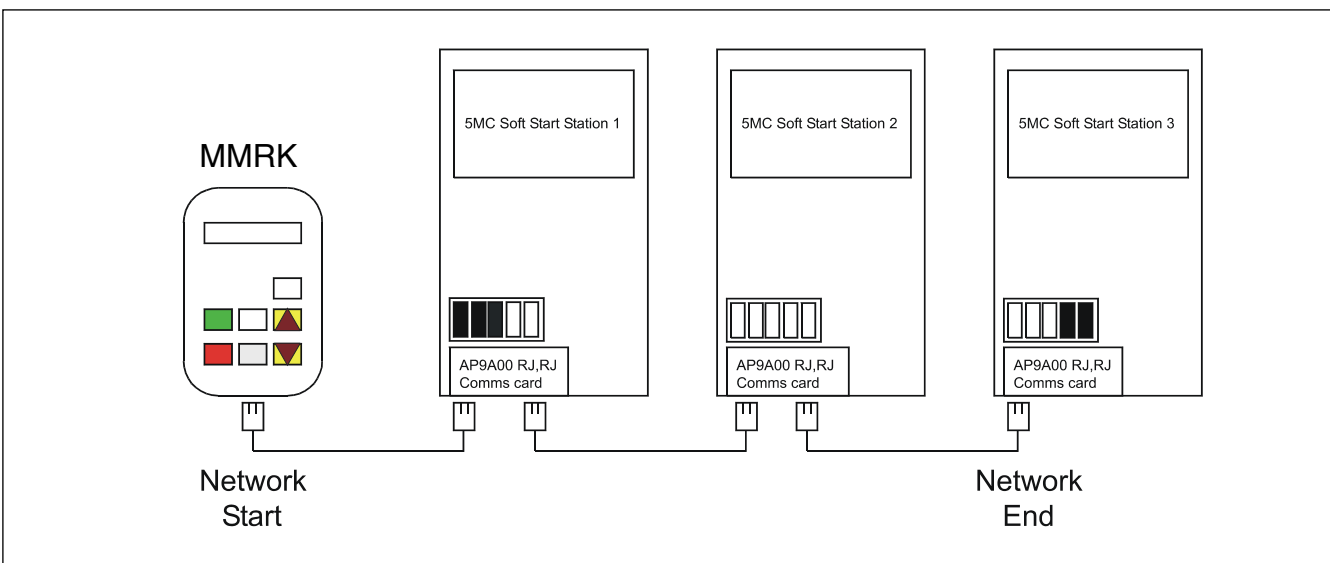

(1): Not cULus approved

(1): Not cULus approved

Connection of multiple RSQK softstarters via RJ45 connectors (1)

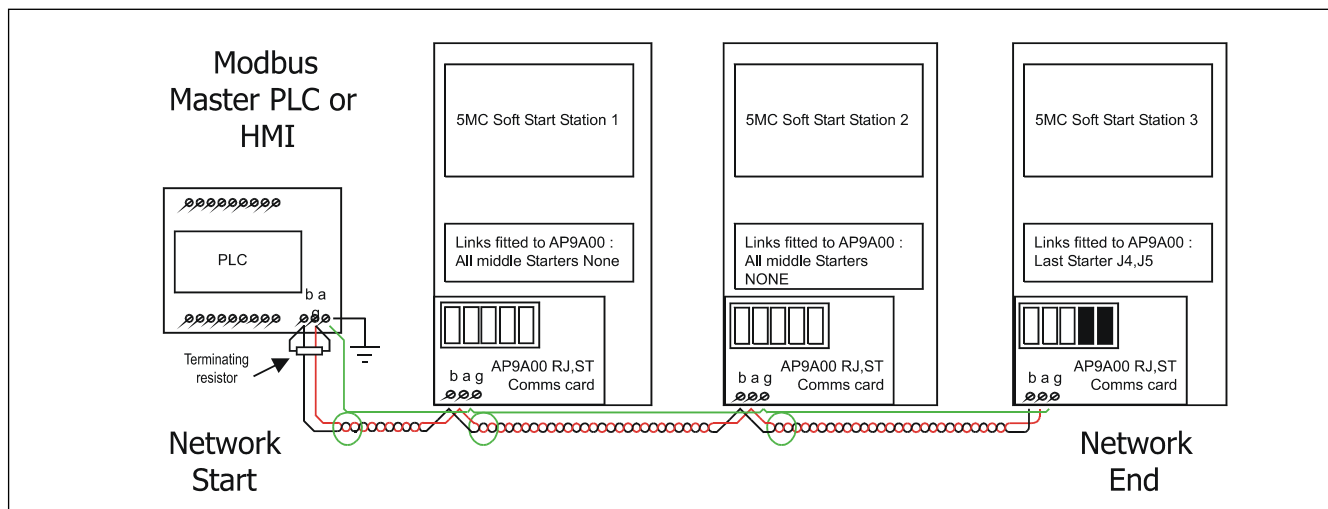

Installation Instructions (J1 - J5 Link Options)

- J1: When linked, 12V is passed through to the RJ45 connectors. This is for use with the Carlo Gavazzi net only. It supplies power to the remote keypad. Only the unit closest to the keypad should have this link fitted.
- J2: When linked, the onboard 1k grounding resistor is shorted out. This is for use with Carlo Gavazzi net only. Only the unit closest to the keypad should have this link fitted.
- J3: When linked, the serial communications isolated ground is connected to the local unit ground. If multiple MAX3157 (isolated comms) chips are connected, J3 must be shorted.
- J4: When linked, a 100ohm terminating resistor is connected between the A and B RS485 lines on both the RJ45 and screw terminal connections. For RS485 networks only, the nodes at each physical end of the network have terminating resistors fitted.
- J5: When linked, a 1k resistor is connected between screw terminal G and local ground. Normally, only one of the units would have this link fitted.
 - When connecting the remote Keypod through the RJ45 connector to a single softstarter, links J1,J2,J4 and J5 should be linked.
 - When connecting the softstarter to a PLC/HMI through twisted pair connection, fit terminating resistor (may be internal) at PLC/HMI end and links J4 and J5 on the softstarter.

Connection Diagram

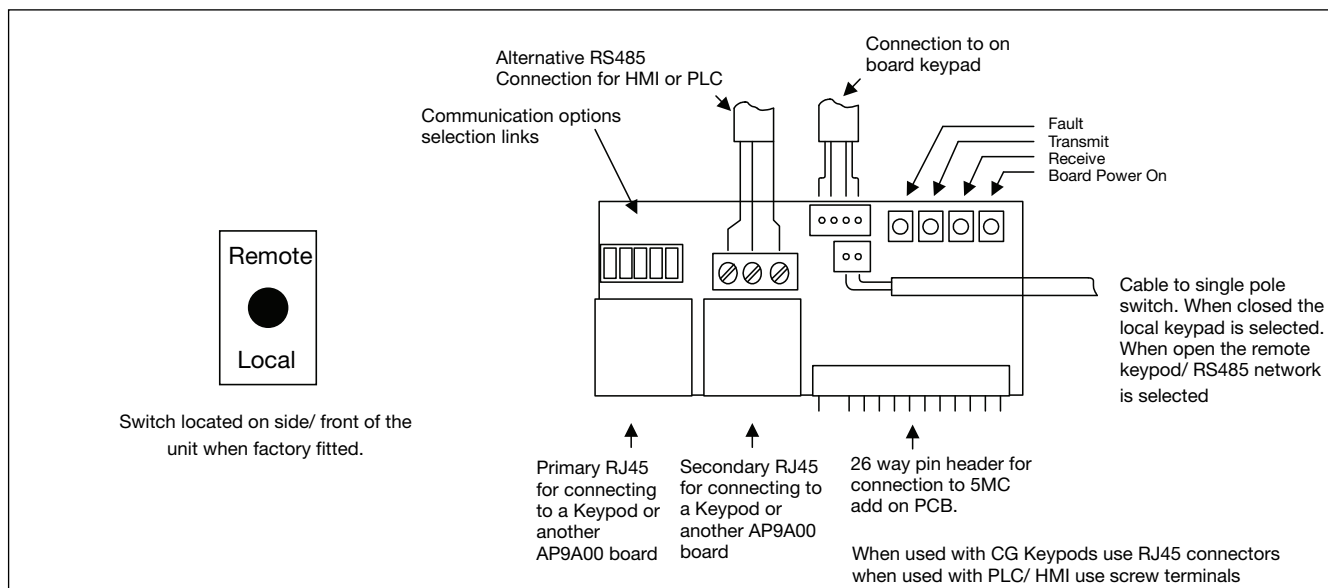

Auxiliary Function Card

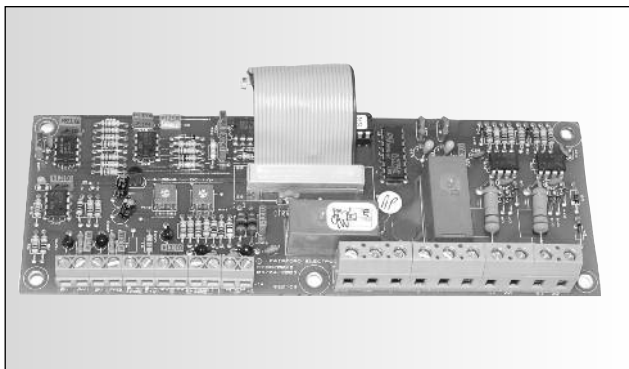

- Ordering Code: MMFC or Option V.F (refer to RSQK ordering code)
- Two 0 - 10V Analogue Outputs
- One 0 - 21V DC Input
- One 4 - 20mA Input
- One Thermistor Input
- Two Programmable Output Relays
- Two Programmable Input Relays

Connection Diagram

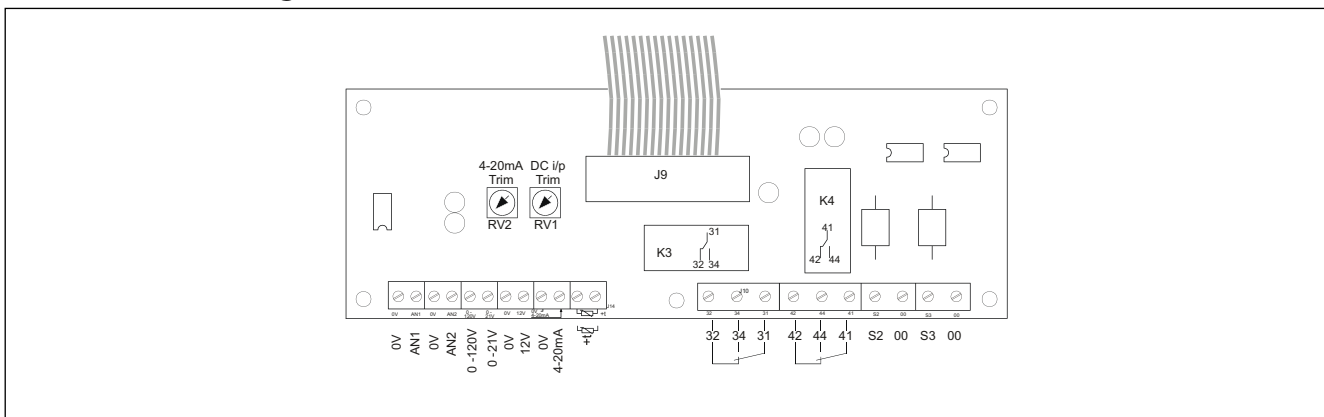

Terminal Markings	Function	Description
0V AN1	Analogue Output 1	A voltage (range 0-10V) represents the analogue value of a selected parameter. (Advanced user facility)
0V AN2	Analogue Output 2	A voltage (range 0-10V) represents the analogue value of a selected parameter. (Advanced user facility)
0-120V	No function	This is an unused terminal
0-21V	DC Input	A 0-21V that is factory pre-set for a 0-10V input range but can be trimmed up by the user to the full 0-21V range. Can be mapped to a selected parameter. (Advanced user facility)
0V	Zero volts	Common 0V terminal for DC input and Voltage Output.
0V 12V	Voltage Output	A voltage source (12V, 100mA max.) for use with either the 4-20mA input or the DC input. (Advanced user facility)
0V 4-20mA	4-20mA Input	Input for an external electronic device with analogue trimming pot. Can be mapped to a selected parameter. (Advanced user facility)
T1 T2	Thermistor Input	Two-wire input for a PTC motor thermistor. P42 indicates the relative value.
32 34 31	Programmable Output Relay K3	Relay K3 Default function - Alarm Changeover contacts that can be mapped from a selected parameter. (Advanced user facility)
42 44 41	Programmable Output Relay K4	Default function - Overload Integrator Changeover contacts that can be mapped from a selected parameter. (Advanced user facility)
S2 00	Programmable Input 2	Control Input 2 Can be mapped to a selected parameter. (Advanced user facility)
S3 00	Programmable Input 3	Control Input 3 Can be mapped to a selected parameter. (Advanced user facility)

По вопросам продаж и поддержки обращайтесь:

Алматы (7273)495-231	Казань (843)206-01-48	Новокузнецк (3843)20-46-81	Смоленск (4812)29-41-54
Архангельск (8182)63-90-72	Калининград (4012)72-03-81	Новосибирск (383)227-86-73	Сочи (862)225-72-31
Астрахань (8512)99-46-04	Калуга (4842)92-23-67	Омск (3812)21-46-40	Ставрополь (8652)20-65-13
Барнаул (3852)73-04-60	Кемерово (3842)65-04-62	Орел (4862)44-53-42	Сургут (3462)77-98-35
Белгород (4722)40-23-64	Киров (8332)68-02-04	Оренбург (3532)37-68-04	Тверь (4822)63-31-35
Брянск (4832)59-03-52	Краснодар (861)203-40-90	Пенза (8412)22-31-16	Томск (3822)98-41-53
Владивосток (423)249-28-31	Красноярск (391)204-63-61	Пермь (342)205-81-47	Тула (4872)74-02-29
Волгоград (844)278-03-48	Курск (4712)77-13-04	Ростов-на-Дону (863)308-18-15	Тюмень (3452)66-21-18
Вологда (8172)26-41-59	Липецк (4742)52-20-81	Рязань (4912)46-61-64	Ульяновск (8422)24-23-59
Воронеж (473)204-51-73	Магнитогорск (3519)55-03-13	Самара (846)206-03-16	Уфа (347)229-48-12
Екатеринбург (343)384-55-89	Москва (495)268-04-70	Санкт-Петербург (812)309-46-40	Хабаровск (4212)92-98-04
Иваново (4932)77-34-06	Мурманск (8152)59-64-93	Саратов (845)249-38-78	Челябинск (351)202-03-61
Ижевск (3412)26-03-58	Набережные Челны (8552)20-53-41	Севастополь (8692)22-31-93	Череповец (8202)49-02-64
Иркутск (395)279-98-46	Нижний Новгород (831)429-08-12	Симферополь (3652)67-13-56	Ярославль (4852)69-52-93
Россия (495)268-04-70	Киргизия (996)312-96-26-47	Казахстан (7172)727-132	

cgo@nt-rt.ru || <https://gavazzi.nt-rt.ru/>