

Carlo Gavazzi



По вопросам продаж и поддержки обращайтесь:

Алматы (7273)495-231
Архангельск (8182)63-90-72
Астрахань (8512)99-46-04
Барнаул (3852)73-04-60
Белгород (4722)40-23-64
Брянск (4832)59-03-52
Владивосток (423)249-28-31
Волгоград (844)278-03-48
Вологда (8172)26-41-59
Воронеж (473)204-51-73
Екатеринбург (343)384-55-89
Иваново (4932)77-34-06
Ижевск (3412)26-03-58
Иркутск (395)279-98-46
Россия (495)268-04-70

Казань (843)206-01-48
Калининград (4012)72-03-81
Калуга (4842)92-23-67
Кемерово (3842)65-04-62
Киров (8332)68-02-04
Краснодар (861)203-40-90
Красноярск (391)204-63-61
Курск (4712)77-13-04
Липецк (4742)52-20-81
Магнитогорск (3519)55-03-13
Москва (495)268-04-70
Мурманск (8152)59-64-93
Набережные Челны (8552)20-53-41
Нижний Новгород (831)429-08-12
Киргизия (996)312-96-26-47

Новокузнецк (3843)20-46-81
Новосибирск (383)227-86-73
Омск (3812)21-46-40
Орел (4862)44-53-42
Оренбург (3532)37-68-04
Пенза (8412)22-31-16
Пермь (342)205-81-47
Ростов-на-Дону (863)308-18-15
Рязань (4912)46-61-64
Самара (846)206-03-16
Санкт-Петербург (812)309-46-40
Саратов (845)249-38-78
Севастополь (8692)22-31-93
Симферополь (3652)67-13-56
Казахстан (7172)727-132

Смоленск (4812)29-41-54
Сочи (862)225-72-31
Ставрополь (8652)20-65-13
Сургут (3462)77-98-35
Тверь (4822)63-31-35
Томск (3822)98-41-53
Тула (4872)74-02-29
Тюмень (3452)66-21-18
Ульяновск (8422)24-23-59
Уфа (347)229-48-12
Хабаровск (4212)92-98-04
Челябинск (351)202-03-61
Череповец (8202)49-02-64
Ярославль (4852)69-52-93

Sensors

Photoelectric sensors	8
Capacitive sensors	34
Inductive sensors	54
Ultrasonic sensors	95
Conductive level sensors	104
Magnetic sensors	108
Safety	115
Connectivity	132
Wind sensors	136

Switches

Solid state relays	140
Solid state relays accessories	177
Soft starters	182
Variable frequency drives	187
Electromechanical relays	189
Sockets for electromechanical relays	194
Switching power supplies	195

Controls

Digital panel meters	212
Energy/Power analyzers	216
Current transformers	226
Data aggregation solutions	235
PV monitoring solutions	240
Building automation	244
Parking guidance system	263
DuplineSafe	267
Fieldbuses	271
Monitoring relays	283
Timers	296

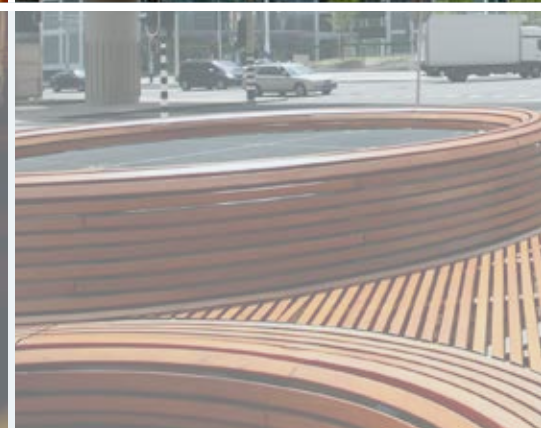
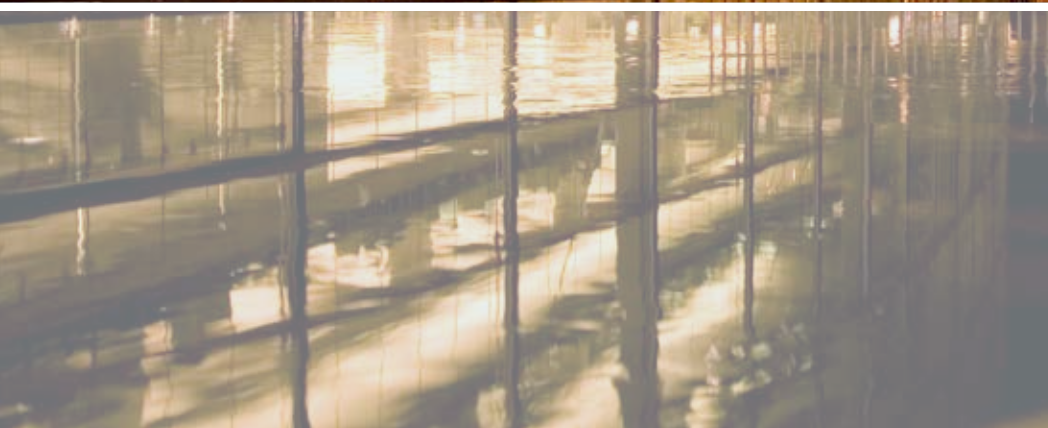

A complete product range

ABOUT CARLO GAVAZZI

Carlo Gavazzi Automation is a multinational electronics group active in the design, manufacture and marketing of electronic equipment targeted at the global markets of industrial and building automation.

Our history is full of firsts and our products are installed in a huge number of applications all over the world. With more than 80 years of successful operation, our experience is unparalleled.

We have our headquarters in Europe and numerous offices around the world.

Our R&D competence centres and production sites are located in Denmark, Italy, Lithuania, Malta and the People's Republic of China.

We operate worldwide through 22 of our own sales companies and also selected representatives in more than 65 countries, from the United States in the West to the Pacific Rim in the East.

Our core competence in automation spans three product lines: Sensors, Switches and Controls.

Our wide array of products includes sensors, monitoring relays, timers, energy management systems, solid state relays, safety devices and fieldbus systems.

We focus our expertise on offering state-of-the-art product solutions in selected market segments.

Our customers include original equipment manufacturers of packaging machines, plastic-injection moulding machines, food and beverage production machines, conveying and materials handling equipment, door and entrance control systems, lifts and escalators, as well as heating, ventilation and air-conditioning devices.



A guarantee of reliability

Carlo Gavazzi products earned the independent approval of the relevant bodies which govern our industry and the many markets we serve.

They are developed and manufactured in full compliance with the most important international standard regulations.

Carlo Gavazzi manufacturing facilities operate in line with the requirements of ISO 9001:2015 Quality Management Systems and ISO 14001:2015 Environmental Management System standard.



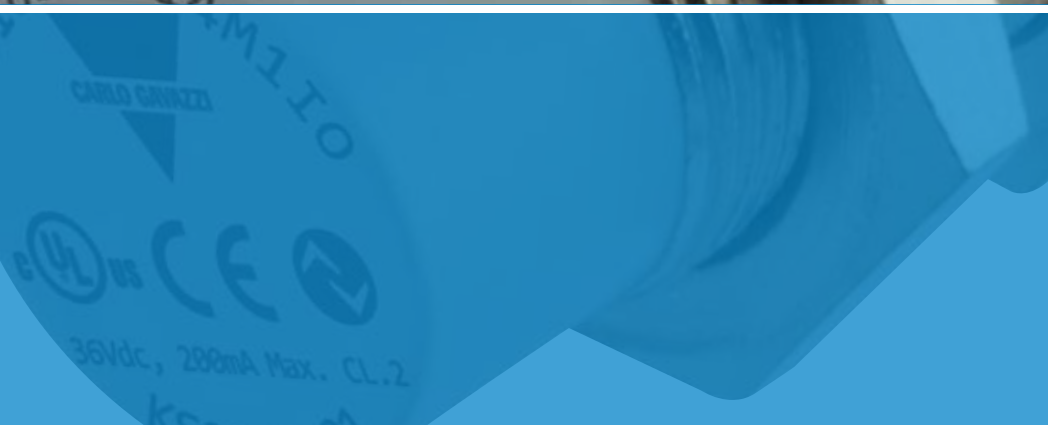





Sensors





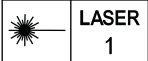
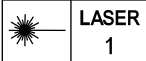
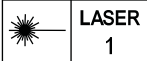
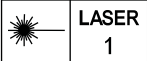

Photoelectric sensors	8
Capacitive sensors	34
Inductive sensors	54
Ultrasonic sensors	95
Conductive level sensors	104
Magnetic sensors	108
Safety	115
Connectivity	132
Wind sensors	136

Photoelectric Time of Flight (ToF) sensors with IO-Link

Integrated amplifier



Types	LD30 Stainless steel AISI 316L		LD30 ABS housing Back potentiometer	
Connections	2 m cable	M8 connector	2 m cable	M8 connector
				
Dimensions (mm)	11 x 31.5 x 21	11 x 31.5 x 21	10 x 30 x 20	10 x 30 x 20
Diffuse reflective background suppression, Infrared Laser - Class 1				
Operating frequency / Sensing distance (Sn)	5 Hz / 1 m	5 Hz / 1 m	5 Hz / 1 m	5 Hz / 1 m
	LD30ETBI10BPA2IO	LD30ETBI10BPM5IO	LD30CTBI10BPA2IO	LD30CTBI10BPM5IO
Specifications				
Detection function	2 separate functions, Single mode, Windows Mode, Two-point Mode	2 separate functions, Single mode, Windows Mode, Two-point Mode	2 separate functions, Single mode, Windows Mode, Two-point Mode	2 separate functions, Single mode, Windows Mode, Two-point Mode
Sensing Principle	Time Of Flight detection (TOF)	Time Of Flight detection (TOF)	Time Of Flight detection (TOF)	Time Of Flight detection (TOF)
Light source	Infrared Laser - Class 1	Infrared Laser - Class 1	Infrared Laser - Class 1	Infrared Laser - Class 1
Analogue output	Via IO-Link	Via IO-Link	Via IO-Link	Via IO-Link
Selectable function output 1	NPN, PNP or Push-Pull	NPN, PNP or Push-Pull	NPN, PNP or Push-Pull	NPN, PNP or Push-Pull
Selectable function output 2	NPN, PNP, Push-Pull, External input or External teach	NPN, PNP, Push-Pull, External input or External teach	NPN, PNP, Push-Pull, External input or External teach	NPN, PNP, Push-Pull, External input or External teach
Diagnostics	Operation hours, Power cycles, Detection cycles max. and min. Temperatures, Short-circuit, Maintenance, No of Parameter change	Operation hours, Power cycles, Detection cycles max. and min. Temperatures, Short-circuit, Maintenance, No of Parameter change	Operation hours, Power cycles, Detection cycles max. and min. Temperatures, Short-circuit, Maintenance, No of Parameter change	Operation hours, Power cycles, Detection cycles max. and min. Temperatures, Short-circuit, Maintenance, No of Parameter change
Logic functions	AND, OR, X-OR, Gated SR-FF	AND, OR, X-OR, Gated SR-FF	AND, OR, X-OR, Gated SR-FF	AND, OR, X-OR, Gated SR-FF
Timer functions	ON delay, OFF delay, ON+OFF delay and One shot	ON delay, OFF delay, ON+OFF delay and One shot	ON delay, OFF delay, ON+OFF delay and One shot	ON delay, OFF delay, ON+OFF delay and One shot
Rated operating voltage	10 - 30 VDC	10 - 30 VDC	10 - 30 VDC	10 - 30 VDC
Voltage drop	≤ 1.0 VDC	≤ 1.0 VDC	≤ 1.0 VDC	≤ 1.0 VDC
No load supply current (I _o)	≤ 20 mA	≤ 20 mA	≤ 20 mA	≤ 20 mA
Protection short-circuit (S)	SPT	SPT	SPT	SPT
Reverse polarity (P)				
Transients (T)				
Output current	< 100 mA	< 100 mA	< 100 mA	< 100 mA
Housing material	Stainless steel AISI 316L	Stainless steel AISI 316L	ABS	ABS
Operating temperature	-25°C to +50°C	-25°C to +50°C	-25°C to +50°C	-25°C to +50°C
Degree of protection	IP68, IP69K	IP68, IP69K	IP67	IP67
LED colour	Yellow + Green	Yellow + Green	Yellow + Green	Yellow + Green
Communication interface	IO-Link	IO-Link	IO-Link	IO-Link
Transmission type	COM2 (38,4 kBaud)	COM2 (38,4 kBaud)	COM2 (38,4 kBaud)	COM2 (38,4 kBaud)
IO-Link revision	01:01:00	01:01:00	01:01:00	01:01:00
SDCI standard	IEC 61131-9	IEC 61131-9	IEC 61131-9	IEC 61131-9
Profiles	Smart Sensor: Process Data Variable; Device Identification	Smart Sensor: Process Data Variable; Device Identification	Smart Sensor: Process Data Variable; Device Identification	Smart Sensor: Process Data Variable; Device Identification
SIO mode	Yes	Yes	Yes	Yes
Required master port type	A	A	A	A
Min. process cycle time [ms]	5	5	5	5
Approvals/Marks	CE - cULus - ECOLAB Class 1 laser according to IEC 60825-1:2014	CE - cULus - ECOLAB Class 1 laser according to IEC 60825-1:2014	CE - cULus Class 1 laser according to IEC 60825-1:2014	CE - cULus Class 1 laser according to IEC 60825-1:2014
				

Photoelectric sensors

	M18, DC, axial type		M18, DC, radial type	
Types	PA18CA.	PA18CA.	PA18CR.	PA18CR.
Connections	2 m cable	M12 connector	2 m cable	M12 connector
				
Dimensions (mm)	M18 x 40	M18 x 44	M18 x 50	M18 x 54
Diffuse reflective				
Sensing distance (Sn)	50 - 1000 mm	50 - 1000 mm	50 - 800 mm	50 - 800 mm
NPN NO+NC	PA18CAD10NASA	PA18CAD10NAM1SA	PA18CRD08NASA	PA18CRD08NAM1SA
PNP NO+NC	PA18CAD10PASA	PA18CAD10PAM1SA	PA18CRD08PASA	PA18CRD08PAM1SA
Diffuse reflective WS				
Sensing distance (Sn)	0 - 400 mm	0 - 400 mm		
NPN NO+NC	PA18CAD04NAWS	PA18CAD04NAM1WS		
PNP NO+NC	PA18CAD04PAWS	PA18CAD04PAM1WS		
Retro reflective polarized				
Sensing distance (Sn)	5 - 500 cm	5 - 500 cm	5 - 400 cm	5 - 400 cm
NPN NO+NC	PA18CAP50NASA	PA18CAP50NAM1SA	PA18CRP40NASA	PA18CRP40NAM1SA
PNP NO+NC	PA18CAP50PASA	PA18CAP50PAM1SA	PA18CRP40PASA	PA18CRP40PAM1SA
Retro reflective				
Sensing distance (Sn)	5 - 650 cm	5 - 650 cm	5 - 500 cm	5 - 500 cm
NPN NO+NC	PA18CAR65NASA	PA18CAR65NAM1SA	PA18CRR50NASA	PA18CRR50NAM1SA
PNP NO+NC	PA18CAR65PASA	PA18CAR65PAM1SA	PA18CRR50PASA	PA18CRR50PAM1SA
Through-beam emitter (E)				
Sensing distance (Sn)	1 - 20 m	1 - 20 m	1 - 16 m	1 - 16 m
	PA18CAT20	PA18CAT20M1	PA18CRT16	PA18CRT16M1
Through-beam receiver (R)				
Sensing distance (Sn)	1 - 20 m	1 - 20 m	1 - 16 m	1 - 16 m
NPN NO+NC	PA18CAT20NASA	PA18CAT20NAM1SA	PA18CRT16NASA	PA18CRT16NAM1SA
PNP NO+NC	PA18CAT20PASA	PA18CAT20PAM1SA	PA18CRT16PASA	PA18CRT16PAM1SA
Background suppression (BGS)				
Sensing distance (Sn)	10 - 200 mm	10 - 200 mm		
NPN NO+NC	PA18CAB20NASA	PA18CAB20NAM1SA		
PNP NO+NC	PA18CAB20PASA	PA18CAB20PAM1SA		
Specifications				
Operating frequency	500 Hz	500 Hz	500 Hz	500 Hz
Rated operating voltage	10 - 30 VDC	10 - 30 VDC	10 - 30 VDC	10 - 30 VDC
Voltage drop	≤ 2.0 VDC @ 100 mA	≤ 2.0 VDC @ 100 mA	≤ 2.0 VDC @ 100 mA	≤ 2.0 VDC @ 100 mA
Degree of protection	IP67 + IP69K	IP67 + IP69K	IP67 + IP69K	IP67 + IP69K
Protection short-circuit (S)				
Reverse polarity (P)	SPT	SPT	SPT	SPT
Transients (T)				
Supply current BGS, E + R	≤ 25 mA @ 24 VDC ≤ 40 mA @ 24 VDC	≤ 25 mA @ 24 VDC ≤ 40 mA @ 24 VDC	≤ 25 mA @ 24 VDC ≤ 40 mA @ 24 VDC	≤ 25 mA @ 24 VDC ≤ 40 mA @ 24 VDC
Housing material	ABS, PMMA, PBTB	ABS, PMMA, PBTB	ABS, PMMA, PBTB	ABS, PMMA, PBTB
Operating temperature	-25°C to +60°C	-25°C to +60°C	-25°C to +60°C	-25°C to +60°C
LED colour	Yellow, Green	Yellow, Green	Yellow, Green	Yellow, Green
Approvals/Marks	CE - cULus - ECOLAB	CE - cULus - ECOLAB	CE - cULus - ECOLAB	CE - cULus - ECOLAB



Photoelectric sensors

M18, DC, square type





Types	PH18.	PH18.	PH18.
Connections	2 m cable	M12 connector	Pigtail M12
			
Dimensions (mm)	15 x 21 (31.5) x 35	15 x 21 (31.5) x 35	15 x 21 (31.5) x 35
Diffuse reflective			
Sensing distance (Sn)	50 - 1000 mm	50 - 1000 mm	50 - 1000 mm
NPN NO+NC	PH18CND10NASA	PH18CND10NAM1SA	PH18CND10NAT1SA
PNP NC+NC	PH18CND10PASA	PH18CND10PAM1SA	PH18CND10PAT1SA
Retro reflective polarized			
Sensing distance (Sn)	5 - 500 cm	5 - 500 cm	5 - 500 cm
NPN NO+NC	PH18CNP50NASA	PH18CNP50NAM1SA	PH18CNP50NAT1SA
PNP NO+NC	PH18CNP50PASA	PH18CNP50PAM1SA	PH18CNP50PAT1SA
Retro reflective			
Sensing distance (Sn)	5 - 650 cm	5 - 650 cm	5 - 650 cm
NPN NO+NC	PH18CNR65NASA	PH18CNR65NAM1SA	PH18CNR65NAT1SA
PNP NO+NC	PH18CNR65PASA	PH18CNR65PAM1SA	PH18CNR65PAT1SA
Through-beam emitter (E)			
Sensing distance (Sn)	1 - 20 m PH18CNT20	1 - 20 m PH18CNT20M1	1 - 20 m PH18CNT20T1
Through-beam receiver (R)			
Sensing distance (Sn)	1 - 20 m	1 - 20 m	1 - 20 m
NPN NO+NC	PH18CNT20NASA	PH18CNT20NAM1SA	PH18CNT20NAT1SA
PNP NO+NC	PH18CNT20PASA	PH18CNT20PAM1SA	PH18CNT20PAT1SA
Background suppression (BGS)			
Sensing distance (Sn)	8 - 200 mm	8 - 200 mm	8 - 200 mm
NPN NO+NC	PH18CNB20NASA	PH18CNB20NAM1SA	PH18CNB20NAT1SA
PNP NO+NC	PH18CNB20PASA	PH18CNB20PAM1SA	PH18CNB20PAT1SA
Specifications			
Operating frequency	500 Hz	500 Hz	500 Hz
Rated operating voltage	10 - 30 VDC	10 - 30 VDC	10 - 30 VDC
Voltage drop	≤ 2.0 VDC @ 100 mA	≤ 2.0 VDC @ 100 mA	≤ 2.0 VDC @ 100 mA
Degree of protection	IP67 + IP69K	IP67 + IP69K	IP67 + IP69K
Protection short-circuit (S)			
Reverse polarity (P)	SPT	SPT	SPT
Transients (T)			
Supply current BGS, E + R	≤ 25 mA @ 24 VDC ≤ 40 mA @ 24 VDC	≤ 25 mA @ 24 VDC ≤ 40 mA @ 24 VDC	≤ 25 mA @ 24 VDC ≤ 40 mA @ 24 VDC
Housing material	ABS, PMMA	ABS, PMMA	ABS, PMMA
Operating temperature	-25°C to +60°C	-25°C to +60°C	-25°C to +60°C
LED colour	Yellow, Green	Yellow, Green	Yellow, Green
Approvals/Marks	CE - cULus - ECOLAB	CE - cULus - ECOLAB	CE - cULus - ECOLAB

Photoelectric sensors

M18 metal, DC, integrated amplifier





Types	E.18..	E.18..-1
Connections	2 m cable	M12 connector
		
Dimensions (mm)	M18 x 55	M18 x 67
Diffuse reflective		
Operating frequency	120 Hz	120 Hz
Sensing distance (Sn)	400 mm, adjustable	400 mm, adjustable
NPN NO+NC	EO1804NPAS	EO1804NPAS-1
PNP NC+NC	EO1804PPAS	EO1804PPAS-1
Retro reflective polarized		
Operating frequency	100 Hz	100 Hz
Sensing distance (Sn)	2 m, adjustable	2 m, adjustable
NPN NO+NC	EP1820NPAS	EP1820NPAS-1
PNP NO+NC	EP1820PPAS	EP1820PPAS-1
Retro reflective		
Operating frequency	120 Hz	120 Hz
Sensing distance (Sn)	3 m, adjustable	3 m, adjustable
NPN NO+NC	ER1830NPAS	ER1830NPAS-1
PNP NO+NC	ER1830PPAS	ER1830PPAS-1
Through-beam emitter		
Sensing distance (Sn)	20 m	20 m
	ET1820	ET1820-1
Through-beam receiver		
Operating frequency	170 Hz	170 Hz
Sensing distance (Sn)	20 m, adjustable	20 m, adjustable
NPN NO+NC	ET1820NPAS	ET1820NPAS-1
PNP NO+NC	ET1820PPAS	ET1820PPAS-1
Specifications		
Rated operating voltage	10 - 40 VDC	10 - 40 VDC
Voltage drop	≤ 2.5 VDC	≤ 2.5 VDC
Degree of protection	IP67	IP67
Protection short-circuit (S)		
Reverse polarity (P)	SPT	SPT
Transients (T)		
Load current	< 200 mA	< 200 mA
Housing material	Nickel-plated brass	Nickel-plated brass
Operating temperature	-20°C to +60°C	-20°C to +60°C
LED colour	Yellow	Yellow
Approvals/Marks	CE	CE

Photoelectric sensors

	M18 plastic, AC, integrated amplifier		M18 metal, AC, integrated amplifier	
Types	PA18CL	PA18CL.M6	PA18AL	PA18AL..M6
Connections	2 m cable	M12 connector	2 m cable	M12 connector
				
Dimensions (mm)	M18 x 71.5	M18 x 83.5	M18 x 71.5	M18 x 83.5
Diffuse reflective				
Operating frequency	20 Hz	20 Hz	20 Hz	20 Hz
Sensing distance (Sn)	100 mm, fixed	100 mm, fixed		
Thyristor (SCR) NC	PA18CLD01TC	PA18CLD01TCM6		
Thyristor (SCR) NO	PA18CLD01TO	PA18CLD01TOM6		
Sensing distance (Sn)	200 mm, fixed	200 mm, fixed		
Thyristor (SCR) NC	PA18CLD02TC	PA18CLD02TCM6		
Thyristor (SCR) NO	PA18CLD02TO	PA18CLD02TOM6		
Sensing distance (Sn)	400 mm, fixed	400 mm, fixed		
Thyristor (SCR) NC	PA18CLD04TC	PA18CLD04TCM6		
Thyristor (SCR) NO	PA18CLD04TO	PA18CLD04TOM6		
Sensing distance (Sn)	400 mm, adjustable	400 mm, adjustable	400 mm, adjustable	400 mm, adjustable
Thyristor (SCR) NC	PA18CLD04TCSA	PA18CLD04TCM6SA	PA18ALD04TCSA	PA18ALD04TCM6SA
Thyristor (SCR) NO	PA18CLD04TOSA	PA18CLD04TOM6SA	PA18ALD04TOSA	PA18ALD04TOM6SA
Retro reflective polarized				
Operating frequency	25 Hz	25 Hz	25 Hz	25 Hz
Sensing distance (Sn)	2 m, fixed	2 m, fixed	2 m, adjustable	2 m, adjustable
Thyristor (SCR) NC	PA18CLP20TC	PA18CLP20TCM6	PA18ALP20TCSA	PA18ALP20TCM6SA
Thyristor (SCR) NO	PA18CLP20TO	PA18CLP20TOM6	PA18ALP20TOSA	PA18ALP20TOM6SA
Retro reflective				
Operating frequency	20 Hz	20 Hz	20 Hz	20 Hz
Sensing distance (Sn)	3 m, fixed	3 m, fixed	3 m, adjustable	3 m, adjustable
Thyristor (SCR) NC	PA18CLR30TC	PA18CLR30TCM6	PA18ALR30TCSA	PA18ALR30TCM6SA
Thyristor (SCR) NO	PA18CLR30TO	PA18CLR30TOM6	PA18ALR30TOSA	PA18ALR30TOM6SA
Specifications				
Rated operating voltage	20 - 250 VAC	20 - 250 VAC	20 - 250 VAC	20 - 250 VAC
Voltage drop	≤ 10 VAC	≤ 10 VAC	≤ 10 VAC	≤ 10 VAC
Off state current	≤ 5 mA AC	≤ 5 mA AC	≤ 5 mA AC	≤ 5 mA AC
Degree of protection	IP67	IP67	IP67	IP67
Protection short-circuit (S)				
Reverse polarity (P)	PT	PT	PT	PT
Transients (T)				
Load current	< 500 mA	< 500 mA	< 500 mA	< 500 mA
Housing material	Polyester (PBTP)	Polyester (PBTP)	Nickel-plated brass	Nickel-plated brass
Operating temperature	-20°C to +60°C	-20°C to +60°C	-20°C to +60°C	-20°C to +60°C
LED colour	Yellow	Yellow	Yellow	Yellow
Approvals/Marks	CE - UL - CSA	CE - UL - CSA	CE - UL - CSA	CE - UL - CSA



Photoelectric sensors

Integrated amplifier

Types	PD30 Stainless steel AISI 316L		PD30 ABS housing Back potentiometer	
	2 m cable	M8 connector	2 m cable	M8 connector
				
Dimensions (mm)	11 x 31.5 x 21	11 x 31.5 x 21	10 x 30 x 20	10 x 30 x 20
Diffuse reflective				
Operating frequency / Sensing distance (Sn)	1000 Hz / 1 m	1000 Hz / 1 m	1000 Hz / 1 m	1000 Hz / 1 m
NPN NO+NC	PD30ETD10NASA	PD30ETD10NAM5SA	PD30CND10NASA	PD30CND10NAM5SA
PNP NO+NC	PD30ETD10PASA	PD30ETD10PAM5SA	PD30CND10PASA	PD30CND10PAM5SA
Diffuse reflective, extremely wide angle, infrared light				
Operating frequency / Sensing distance (Sn)	1000 Hz / 200 mm	1000 Hz / 200 mm		
NPN NO+NC	PD30ETD02NAWE	PD30ETD02NAM5WE		
PNP NO+NC	PD30ETD02PAWE	PD30ETD02PAM5WE		
Diffuse reflective background suppression, red light				
Operating frequency / Sensing distance (Sn)	500 Hz / 200 mm	500 Hz / 200 mm	500 Hz / 200 mm	500 Hz / 200 mm
NPN NO+NC	PD30ETB20NASA	PD30ETB20NAM5SA	PD30CNB20NASA	PD30CNB20NAM5SA
PNP NO+NC	PD30ETB20PASA	PD30ETB20PAM5SA	PD30CNB20PASA	PD30CNB20PAM5SA
Diffuse reflective background suppression, infrared light				
Operating frequency / Sensing distance (Sn)	500 Hz / 200 mm	500 Hz / 200 mm	500 Hz / 200 mm	500 Hz / 200 mm
NPN NO+NC	PD30ETB20NAIS	PD30ETB20NAM5IS	PD30CNB20NAIS	PD30CNB20NAM5IS
PNP NO+NC	PD30ETB20PAIS	PD30ETB20PAM5IS	PD30CNB20PAIS	PD30CNB20PAM5IS
Retro reflective				
Operating frequency / Sensing distance (Sn)	1000 Hz / 6 m	1000 Hz / 6 m	1000 Hz / 6 m	1000 Hz / 6 m
NPN NO+NC	PD30ETR60NASA	PD30ETR60NAM5SA	PD30CNR60NASA	PD30CNR60NAM5SA
PNP NO+NC	PD30ETR60PASA	PD30ETR60PAM5SA	PD30CNR60PASA	PD30CNR60PAM5SA
Retro reflective polarized				
Operating frequency / Sensing distance (Sn)	1000 Hz / 6 m	1000 Hz / 6 m	1000 Hz / 6 m	1000 Hz / 6 m
NPN NO+NC	PD30ETP60NASA	PD30ETP60NAM5SA	PD30CNP60NASA	PD30CNP60NAM5SA
PNP NO+NC	PD30ETP60PASA	PD30ETP60PAM5SA	PD30CNP60PASA	PD30CNP60PAM5SA
Through-beam emitter				
Sensing distance (Sn)	15 m	15 m	15 m	15 m
	PD30ETT15	PD30ETT15M5	PD30CNT15	PD30CNT15M5
Through-beam receiver				
Operating frequency / Sensing distance (Sn)	500 Hz / 15 m	500 Hz / 15 m	500 Hz / 15 m	500 Hz / 15 m
NPN NO/NC	PD30ETT15NASA	PD30ETT15M5NASA	PD30CNT15NASA	PD30CNT15NAM5SA
PNP NO/NC	PD30ETT15PASA	PD30ETT15M5PASA	PD30CNT15PASA	PD30CNT15PAM5SA
Specifications				
Rated operating voltage	10 - 30 VDC	10 - 30 VDC	10 - 30 VDC	10 - 30 VDC
Voltage drop	≤ 2.0 VDC @ 100 mA	≤ 2.0 VDC @ 100 mA	≤ 2.0 VDC @ 100 mA	≤ 2.0 VDC @ 100 mA
Degree of protection	IP68, IP69K	IP68, IP69K	IP67	IP67
Protection short-circuit (S)				
Reverse polarity (P)	SPT	SPT	SPT	SPT
Transients (T)				
Load current	≤ 100 mA	≤ 100 mA	≤ 100 mA	≤ 100 mA
Housing material	Stainless steel AISI 316L	Stainless steel AISI 316L	ABS	ABS
Operating temperature	-40 (-25)°C to +60°C	-40 (-25)°C to +60°C	-25°C to +60°C	-25°C to +60°C
LED colour	Yellow + Green	Yellow + Green	Yellow + Green	Yellow + Green
Approvals/Marks ULS08	CE - cULus - ECOLAB	CE - cULus - ECOLAB	CE - cULus	CE - cULus





Photoelectric sensors

Integrated amplifier

Types	PD30 PointSpot Back potentiometer		PD30 Top potentiometer
Connections	2 m cable	M8 connector	2 m cable
			
Dimensions (mm)	10 x 30 x 20	10 x 30 x 20	10 x 30 x 20
Diffuse reflective			
Operating frequency / Sensing distance (Sn)			1000 Hz / 1 m
NPN NO+NC			PD30CTD10NASA
PNP NO+NC			PD30CTD10PASA
Diffuse reflective, extremely wide angle, infrared light			
Operating frequency / Sensing distance (Sn)			1000 Hz / 200 mm
NPN NO+NC			PD30CTD02NAWE
PNP NO+NC			PD30CTD02PAWE
Diffuse reflective background suppression, red light			
Operating frequency / Sensing distance (Sn)	500 Hz / 250 mm	500 Hz / 250 mm	500 Hz / 200 mm
NPN NO+NC	PD30CNB25NAPS	PD30CNB25NAM5PS	PD30CTB20NASA
PNP NO+NC	PD30CNB25PAPS	PD30CNB25PAM5PS	PD30CTB20PASA
Diffuse reflective background suppression, infrared light			
Operating frequency / Sensing distance (Sn)			500 Hz / 200 mm
NPN NO+NC			PD30CTB20NAIS
PNP NO+NC			PD30CTB20PAIS
Retro reflective polarized			
Operating frequency / Sensing distance (Sn)	1000 Hz / 5 m	1000 Hz / 5 m	
NPN NO+NC	PD30CNP50NAPS	PD30CNP50NAM5PS	
PNP NO+NC	PD30CNP50PAPS	PD30CNP50PAM5PS	
Specifications			
Rated operating voltage	10 - 30 VDC	10 - 30 VDC	10 - 30 VDC
Voltage drop	≤ 2.0 VDC @ 100 mA	≤ 2.0 VDC @ 100 mA	≤ 2.0 VDC @ 100 mA
Degree of protection	IP67	IP67	IP67
Protection short-circuit (S)			
Reverse polarity (P)	SPT	SPT	SPT
Transients (T)			
Load current	≤ 100 mA	≤ 100 mA	≤ 100 mA
Housing material	ABS	ABS	ABS
Operating temperature	-25°C to +60°C	-25°C to +60°C	-25°C to +60°C
LED colour	Yellow + Green	Yellow + Green	Yellow + Green
Approvals/Marks UL508	CE - cULus	CE - cULus	CE - cULus

Photoelectric sensors

Integrated amplifier

Types	PD30 - Advanced with teach-in			
Connections	2 m cable	M8 connector	2 m cable	M8 connector
				
Dimensions (mm)	10 x 30 x 20	10 x 30 x 20	10 x 30 x 20	10 x 30 x 20
Retro reflective		Retro reflective - transparent objects		
Operating frequency / Sensing distance (Sn)	1000 Hz / 6 m, Teach-in	1000 Hz / 6 m, Teach-in	1000 Hz / 2 m, Teach-in	1000 Hz / 2 m, Teach-in
Mute NPN NO/NC	PD30CNR06NPMU	PD30CNR06NPM5MU	PD30CNG02NPMU	PD30CNG02NPM5MU
Mute PNP NO/NC	PD30CNR06PPMU	PD30CNR06PPM5MU	PD30CNG02PPMU	PD30CNG02PPM5MU
Dust NPN NO/NC	PD30CNR06NPDU	PD30CNR06NPM5DU		
Dust PNP NO/NC	PD30CNR06PPDU	PD30CNR06PPM5DU		
Remote NPN NO/NC	PD30CNR06NPRT	PD30CNR06NPM5RT	PD30CNG02NPRT	PD30CNG02NPM5RT
Remote PNP NO/NC	PD30CNR06PPRT	PD30CNR06PPM5RT	PD30CNG02PPRT	PD30CNG02PPM5RT
Retro reflective polarized		Diffuse reflective		
Operating frequency / Sensing distance (Sn)	1000 Hz / 6 m, Teach-in	1000 Hz / 6 m, Teach-in	1000 Hz / 1 m, Teach-in	1000 Hz / 1 m, Teach-in
Mute NPN NO/NC	PD30CNP06NPMU	PD30CNP06NPM5MU		
Mute PNP NO/NC	PD30CNP06PPMU	PD30CNP06PPM5MU		
Dust NPN NO/NC	PD30CNP06NPDU	PD30CNP06NPM5DU	PD30CND10NPDU	PD30CND10NPM5DU
Dust PNP NO/NC	PD30CNP06PPDU	PD30CNP06PPM5DU	PD30CND10PPDU	PD30CND10PPM5DU
Remote NPN NO/NC	PD30CNP06NPRT	PD30CNP06NPM5RT	PD30CND10NPRT	PD30CND10NPM5RT
Remote PNP NO/NC	PD30CNP06PPRT	PD30CNP06PPM5RT	PD30CND10PPRT	PD30CND10PPM5RT
Through-beam emitter				
Sensing distance (Sn)	15 m, Teach-in	15 m, Teach-in		
NPN	PD30CNT15NMU	PD30CNT15NM5MU		
PNP	PD30CNT15PMU	PD30CNT15PM5MU		
Through-beam receiver mute function		Diffuse reflective background suppression		
Operating frequency / Sensing distance (Sn)	1000 Hz / 15 m, Teach-in	1000 Hz / 15 m, Teach-in	1000 Hz / 150 mm, Teach-in	1000 Hz / 150 mm, Teach-in
Remote NPN NO/NC	PD30CNT15NPRT	PD30CNT15NPM5RT	PD30CNB15NPRT	PD30CNB15NPM5RT
Remote PNP NO/NC	PD30CNT15PPRT	PD30CNT15PPM5RT	PD30CNB15PPRT	PD30CNB15PPM5RT
Dust NPN NO/NC	PD30CNT15NPDU	PD30CNT15NPM5DU		
Dust PNP NO/NC	PD30CNT15PPDU	PD30CNT15PPM5DU		
Specifications				
Rated operating voltage	10 - 30 VDC	10 - 30 VDC	10 - 30 VDC	10 - 30 VDC
Voltage drop	≤ 2.4 VDC @ 100 mA	≤ 2.4 VDC @ 100 mA	≤ 2.4 VDC @ 100 mA	≤ 2.4 VDC @ 100 mA
Degree of protection	IP67	IP67	IP67	IP67
Protection short-circuit (S)				
Reverse polarity (P)	SPT	SPT	SPT	SPT
Transients (T)				
Load current	≤ 100 mA	≤ 100 mA	≤ 100 mA	≤ 100 mA
Housing material	ABS	ABS	ABS	ABS
Operating temperature	-25°C to +55°C	-25°C to +55°C	-25°C to +55°C	-25°C to +55°C
LED colour	Yellow + Green	Yellow + Green	Yellow + Green	Yellow + Green
Approvals/Marks UL508	CE - cULus	CE - cULus	CE - cULus	CE - cULus

Photoelectric sensors

Through-beam, transistor output

Types	PB10..	PA12	PB18..	PE12..
Connections	5 m cable	M12 connector	5 m cable	5 m cable
				

Dimensions (mm)	Ø10	M12	Ø18	Ø12
-----------------	-----	-----	-----	-----

Through-beam emitter

Sensing distance (Sn)	20 m	20 m	15 m	15 m
Single channel	PB10CNT20	PA12BNT20	PB18CNT15	PE12CNT15
Channel 1	PB10C1T20	PA12B1T20		PE12C1T15
Channel 2	PB10C2T20	PA12B2T20		PE12C2T15
Channel 3	PB10C3T20	PA12B3T20		PE12C3T15

Through-beam receiver

Operating frequency	100 Hz (for 3 ch 30 Hz)	100 Hz (for 3 ch 30 Hz)	100 Hz	100 Hz
Sensing distance (Sn)	20 m	20 m	15 m	15 m
NPN NO Single channel	PB10CNT20NO	PA12BNT20NO	PB18CNT15NO	PE12CNT15NO
NPN NC Single channel	PB10CNT20NC	PA12BNT20NC	PB18CNT15NC	PE12CNT15NC
PNP NO Single channel	PB10CNT20PO	PA12BNT20PO	PB18CNT15PO	PE12CNT15PO
PNP NC Single channel	PB10CNT20PC	PA12BNT20PC	PB18CNT15PC	PE12CNT15PC
NPN NO Channel 1	PB10C1T20NO	PA12B1T20NO		PE12C1T15NO
NPN NC Channel 1	PB10C1T20NC	PA12B1T20NC		PE12C1T15NC
PNP NO Channel 1	PB10C1T20PO	PA12B1T20PO		PE12C1T15PO
PNP NC Channel 1	PB10C1T20PC	PA12B1T20PC		PE12C1T15PC
NPN NO Channel 2	PB10C2T20NO	PA12B2T20NO		PE12C2T15NO
NPN NC Channel 2	PB10C2T20NC	PA12B2T20NC		PE12C2T15NC
PNP NO Channel 2	PB10C2T20PO	PA12B2T20PO		PE12C2T15PO
PNP NC Channel 2	PB10C2T20PC	PA12B2T20PC		PE12C2T15PC
NPN NO Channel 3	PB10C3T20NO	PA12B3T20NO		PE12C3T15NO
NPN NC Channel 3	PB10C3T20NC	PA12B3T20NC		PE12C3T15NC
PNP NO Channel 3	PB10C3T20PO	PA12B3T20PO		PE12C3T15PO
PNP NC Channel 3	PB10C3T20PC	PA12B3T20PC		PE12C3T15PC

Specifications

Rated operating voltage	10 - 30 VDC	10 - 30 VDC	10 - 30 VDC	10 - 30 VDC
Voltage drop	≤ 1.5 VDC	≤ 1.5 VDC	≤ 1.5 VDC	≤ 1.5 VDC
Degree of protection	IP67	IP67	IP67	IP67
Protection short-circuit (S)				
Reverse polarity (P)	SPT	SPT	SPT	SPT
Transients (T)				
Load current	≤ 100 mA	≤ 100 mA	≤ 100 mA	≤ 100 mA
Housing material	PC	PC	PTE	PC
Operating temperature	-20°C to +50°C	-20°C to +50°C	-20°C to +50°C	-20°C to +50°C
LED colour	Green (E), Yellow (R)	Green (E), Yellow (R)		Green (E), Yellow (R)
Approvals/Marks	CE	CE	CE	CE
UL 508	cULus	UL - cUL	cULus	cULus
UL 325	cURus	UR - cURus	cURus	cURus

NB! For pig-tail connector versions add C2 after the part number

Photoelectric sensors

DC, integrated amplifier

Types	PD70	PD112	PA.	PB.
Connections	2 m cable or connector		2 m cable or connector	
				

Dimensions (mm)	11.6 x 11.6 x 70	112 x 45 x 25	36 x 18 x 63	18 x 75 x 36
-----------------	------------------	---------------	--------------	--------------

Diffuse reflective background suppression

Operating frequency		Door mode 16.7 Hz Industry mode 250 Hz	1000 Hz	1000 Hz
Sensing distance (Sn)		2.5 m, adjustable	150 mm, adjustable	150 mm, adjustable
Cable		2 m	2 m	2 m
NPN/PNP, NO+NC		-	PA15INPA/PA15IPPA	PB15INPA/PB15IPPA
NPN+PNP, NO/NC		PD112CNB25BP	-	-
Connector		M12	M12	M12
NPN/PNP, NO+NC		-	PA15INPA-1/PA15IPPA-1	PB15INPA-1/PB15IPPA-1
NPN+PNP, NO/NC		PD112CNB25BPM1		

Retro reflective polarized

Operating frequency			1000 Hz	1000 Hz
Sensing distance (Sn)			3 m, adjustable	3 m, adjustable
Cable			2 m	2 m
NPN/PNP, NO+NC			PA3PNPA/PA3PPPA	PB3PNPA/PB3PPPA
Connector			M12	M12
NPN/PNP, NO+NC			PA3PNPA-1/PA3PPPA-1	PB3PNPA-1/PB3PPPA-1

Through-beam



Operating frequency	100 Hz			
Sensing distance (Sn)	12 m, adjustable			
Cable	2 m			
NPN NO (Receiver)	PD70CNT12NO			
NPN NC (Receiver)	PD70CNT12NC			
PNP NO (Receiver)	PD70CNT12PO			
PNP NC (Receiver)	PD70CNT12PC			
Mute High (Emitter)	PD70CNT12MH			
Mute Low (Emitter)	PD70CNT12ML			
Connector	M8			
NPN NO (Receiver)	PD70CNT12NOM5			
NPN NC (Receiver)	PD70CNT12NCM5			
PNP NO (Receiver)	PD70CNT12POM5			
PNP NC (Receiver)	PD70CNT12PCM5			
Mute High (Emitter)	PD70CNT12M5MH			
Mute Low (Emitter)	PD70CNT12M5ML			

Specifications



Rated operating voltage	10 - 30 VDC	10 - 30 VDC	10 - 30 VDC	10 - 30 VDC
Voltage drop	≤ 1.8 VDC	≤ 2.5 VDC	≤ 2.5 VDC	≤ 2.5 VDC
Degree of protection	IP67	IP67	IP67	IP67
Protection short-circuit (S)				
Reverse polarity (P)	SPT	SPT	SPT	SPT
Transients (T)				
Load current	≤ 100 mA	< 200 mA	< 200 mA	< 200 mA
Housing material	PC Black	PC Black	Aluminium	Reinforced ABS
Operating temperature	-25°C to +55°C	-25°C to +55°C	-25°C to +60°C	-25°C to +60°C
LED colour	Yellow, Receiver output Green, Emitter power ON	Yellow, Output Green, Power ON	Yellow	Yellow
Approvals/Marks	CE - cURus	CE - cULus	CE	CE

Photoelectric sensors





Integrated amplifier

Types	PC50	PC50..M1	PC50
Connections	2 m cable	M12 connector	2 m cable
			
Dimensions (mm)	17 x 50 x 50	17 x 50 x 50	17 x 50 x 50
Diffuse reflective			
Operating frequency	500 Hz	500 Hz	20 Hz
Sensing distance (Sn)	1 m, adjustable	1 m, adjustable	
NPN/PNP NO+NC	PC50CND10BA	PC50CND10BAM1	
Sensing distance (Sn)	2 m, adjustable	2 m, adjustable	
NPN/PNP NO+NC	PC50CND20BA	PC50CND20BAM1	
Sensing distance (Sn)			1 m, adjustable
Relay SPDT Multivoltage			PC50CND10RP
Sensing distance (Sn)			2 m, adjustable
Relay SPDT Multivoltage			PC50CND20RP
Diffuse reflective background suppression			
Operating frequency	250 Hz	250 Hz	
Sensing distance (Sn)	500 mm, adjustable	500 mm, adjustable	
NPN/PNP NO+NC	PC50CNB50BA	PC50CNB50BAM1	
Retro reflective polarized			
Operating frequency	500 Hz	500 Hz	20 Hz
Sensing distance (Sn)	6 m, adjustable	6 m, adjustable	6 m, adjustable
NPN/PNP NO+NC	PC50CNP06BA	PC50CNP06BAM1	
Mute High	PC50CNP06BAMH	PC50CNP06BAM1MH	
Mute Low	PC50CNP06BAML	PC50CNP06BAM1ML	
Relay SPDT Multivoltage			PC50CNP06RP
Retro reflective			
Operating frequency	500 Hz	500 Hz	20 Hz
Sensing distance (Sn)	10 m, adjustable	10 m, adjustable	10 m, adjustable
NPN/PNP NO+NC	PC50CNR10BA	PC50CNR10BAM1	
Relay SPDT Multivoltage			PC50CNR10RP
Through-beam emitter			
Sensing distance (Sn)	20 m	20 m	20 m
	PC50CNT20B	PC50CNT20BM1	PC50CNT20R
Through-beam receiver			
Operating frequency	500 Hz	500 Hz	20 Hz
Sensing distance (Sn)	20 m, adjustable	20 m, adjustable	20 m, adjustable
NPN/PNP NO+NC	PC50CNT20BA	PC50CNT20BAM1	-
Relay SPDT Multivoltage			PC50CNT20RP
Specifications			
Rated operating voltage	10 - 30 VDC	10 - 30 VDC	12 - 240 VDC / 24 - 240 VAC
Voltage drop	≤ 2.5 VDC	≤ 2.5 VDC	Relay SPDT
Degree of protection	IP67	IP67	IP67
Protection short-circuit (S)			
Reverse polarity (P)	SPT	SPT	PT
Transients (T)			
Load current	≤ 200 mA	≤ 200 mA	≤ 3 mA
Housing material	Reinforced ABS/PC	Reinforced ABS/PC	Reinforced ABS/PC
Operating temperature	-20°C to +60°C	-20°C to +60°C	-20°C to +60°C
LED colour	Yellow + Green	Yellow + Green	Yellow + Green
Approvals/Marks	CE - UL - CSA	CE - UL - CSA	CE - UL - CSA

Photoelectric sensors

	Fork sensor	Fiber optic sensor
Types	PF74..	FA1
Connections	5 m cable	2 m cable
		
Dimensions (mm)	15 x 60 x 74	10 x 33 x 80
Fork sensor		
Operating frequency	≤ 1100 Hz	
Sensing distance (Sn)	30 mm, slot width	
PNP NO, NPN NC	PF74CNT30BC	
PNP NC, NPN NO	PF74CNT30BO	
Diffuse reflective		
Operating frequency		200, 500, 1000, 5000 μS
Sensing distance (Sn)		Fiber dependent
NPN NO or NC		FA1-N
PNP NO or NC		FA1-P
General specifications		
Rated operating voltage	19.2 - 28.8 VDC	12 to 24 VDC
Voltage drop	≤ 1.5 VDC @ 100 mA	≤ 1.5 VDC
Degree of protection	IP65	IP40
Protection short-circuit (S)		
Reverse polarity (P)	SPT	SPT
Transients (T)		
Load current	≤ 30 mA	≤ 100 mA
Housing material	PC, black	ABS
Operating temperature	-25°C to +60°C	0°C to +60°C
LED colour	Yellow + Green	Red + Green
Approvals/Marks UL508	CE	CE - cULus (UL508)
Light source		Red LED 660 nm
Plastic fiber unit		FUR (reflective) & FUT (through beam) series. Please refer to FUR FUT specifications datasheets



Photoelectric sensors

	Integrated amplifier relay output			Through-beam relay output
Types	PM..	PM..	PD86	PD98
Connections	Terminals single relay	Terminal block mute input	Terminal block mute input	Terminal block mute input
				
Dimensions (mm)	25 x 65 x 81	25 x 65 x 81	86 x 44 x 39	98 x 56 x 37
Diffuse reflective				
Oper. freq. / Sens. dist. (Sn)	20 Hz			
Sensing distance (Sn)	0.8 m, adjustable			
Relay SPDT Multivoltage	PMD8RG / RGT PMD8RI / RIT			
Retro reflective polarized				
Oper. freq. / Sens. dist. (Sn)	20 Hz / 12 m, fixed	20 Hz / 12 m, fixed	20 Hz / 12 m, fixed	
Relay SPDT Multivoltage	PMP12RG / PMP12RI		PD86CNP12QPMU	
Relay SPST (PC)	PMP12RGM / PMP12RIM		PD86CAP12QPTD	
Relay SPST (PC) - Detachable Terminals			PD86CAP12QPTE	
Relay SPST (PC) - Fixed Terminals			PD86CAP12QPTF	
Relay SPST (ZAMAK)			PD86HNP12QPMU-01C	
Relay SPST (ZAMAK) - Detachable Terminals			PD86HAP12QPTD-01C	
Relay SPST (ZAMAK) - Fixed Terminals			PD86HAP12QPTF-01C	
Retro reflective				
Oper. freq. / Sens. dist. (Sn)	20 Hz / 10 m, fixed			
Relay SPDT Multivoltage	PMR10RG / RGT			
Relay SPST	PMR10RI / RIT			
Through-beam emitter				
Sensing distance (Sn)	20 m	20 m	30 m (15 m default)	
	PMT20G / PMT20I	PMT20GM / PMT20IM	PD98CNT30QMU*	
Through-beam receiver				
Oper. freq. / Sens. dist. (Sn)	20 Hz / 20 m, fixed	20 Hz / 20 m, fixed		25 Hz / 30 m (15 m default)
Relay SPDT Multivoltage	PMT20RG / RGT PMT20RI / RIT			
Relay SPST				
General specifications				
Rated operating voltage	12 - 240 VDC / 24 - 240 VAC	24 VAC/DC ±20%	24 VAC/DC ±20%	12 V to 24 VAC/DC
Voltage drop	Relay SPDT	Relay SPST	Relay SPST	Relay DPDT
Degree of protection	IP67	IP67	IP66	IP54
Protection short-circuit (S)				
Reverse polarity (P)	PT	PT	PT	PT
Transients (T)				
Load current	≤ 3 A	≤ 3 A	1 A (AC), 0.5 A (DC)	1 A (AC), 0.5 A (DC)
Housing material	PC/ABS	PC/ABS	PD86C.. : PC + PMMA PD86H.. : ZAMAK + PMMA	PC/ABS
Operating temperature	-25°C to +55°C	-25°C to +55°C	-25°C to +60°C	-25°C to +60°C
LED colour	Yellow	Yellow	Yellow + Green	Yellow (receiver)
Approvals/Marks	CE - UL - CSA	CE - UL325 - UL508	CE - UL325 - UL508	CE - UL325
Remarks	G = PG 13.5 Outlet I = ½"NPT Outlet T = Timer	G = PG 13.5 Outlet I = ½"NPT Outlet Mute input	Mute input CA and HA types: Angular detection and adjustable lenses ± 4,5°	Mute input





* Item number set, emitter + receiver.

CARLO GAVAZZI Automation Components. Specifications are subject to change without notice. Illustrations are for example only.

Photoelectric sensors

	Heavy duty infrared barrier	Through-beam relay output
Types	PD140	PD180
Connections	Terminal block	Terminal block
		
Dimensions (mm)	140 x 51 x 46	180 x 51 x 49
Through-beam range		
Indoor sensing distance (max)	60 m outdoor	15 / 30 m
General specifications		
Technology	Infrared	Infrared
Supply voltage receiver or emitter	12...24 VAC/VDC	12 + 24 VAC/DC
Battery supply emitter		2 x 3,6 VDC, 2100 mAh Lithium batteries size AA
Consumption	155 mA to 24 VAC (Emitter and receiver)	35 mA DC (55 mA DC with low battery alarm)
Output	SPDT	2 x SPST
Contact rating	1 A /@ 30 VDC, 0.5 A @ 50 VAC (resistive load)	1 A @ 30 VDC, 0.5 A @ 30 VAC (resistive load)
Approvals	CE - UL325 - UL508	CE - UL325 - CSA
Conformity	EN 12445, EN 12453, EN12978, EN/ISO 13849-1 ESPE2, RoHS	EN 12445, EN12453, EN12978, EN/ISO 13849-1 ESPE2, RoHS
Test input	Emitter test input	Emitter test input
Environmental specifications		
Wavelength	850 nm	850 nm
Operating temperature	-20°C to +60°C	-25°C to +55°C
Degree of protection	IP65	IP55
Mechanical specifications		
LED transmitter	Power signal	None (energy saving)
LED receiver	Signal for alignment with transmitter	Power ON - Green LED Output - Yellow LED
Optical adjustment	Horizontal 200° Vertical ±15°	Horizontal 200° Vertical ±30°
Mounting	Wall mounted type	Wall mounted type
Material	Aluminium, PC	PC
Weight	460 g (set)	Emitter 270 g Receiver 230 g
Comments	ESPE Category 2, EN 61496-2 Accessory: Laser alignment tool	ESPE Category 2, EN 61496-2 Emitter is supplied with 2 x 3.6 VDC 2100 mAh lithium batteries
Accessories	APD140-LA01 APD140-LA02 APD140-TC01	

Photoelectric sensors

	Sensors	Amplifier 1-channel	Amplifier 2-channel	Amplifier 3-channel
Types	MPF..	MPF1..	MPF2..	MPF3..
Connections	10 m cable	Terminals	Terminals	Terminals
				
Dimensions (mm)	See sensor type	70 x 57 x 86	70 x 57 x 86	70 x 57 x 86
Amplifier				
		1-Channel	2-Channel	3-Channel
12-24 VAC/DC ±15%		MPF1-912RSL	MPF2-912RSL	MPF3-912RSL
Low current		MPF1-912RS	MPF2-912RS	MPF3-912RS
12-24 VAC/DC ±15%		MPF1-115RS	MPF2-115RS	MPF3-115RS
115 VAC ±15%		MPF1-230RS	MPF2-230RS	MPF3-230RS
230 VAC ±15%				
Through-beam emitter		Output and function selection		
Sensing distance (Sn)	15 m	No Dist Adjust		Dist Adjust
Ø12 x 20	MPFT15-4 (C)	Normal Mute	Inverted Mute	Normal Mute Inverted Mute
D11 x 24.5	MPFT15-D11-4			
D18 x 25	MPFT15-D18-4 (C)	RS	RSI	RSA RSAI
M14 x 23	MPFT15-M14-4 (C)	RSL	RSLI	RSLA RSLAI
Through-beam receiver				
Sensing distance (Sn)	15 m			
Ø12 x 20	MPFR-4 (C)			
D11 x 24.5	MPFR-D11-4			
D18 x 25	MPFR-D18-4 (C)			
M14 x 23	MPFR-M14-4 (C)			
General specifications				
Rated operating voltage	Powered by amplifier	See amplifier reference	See amplifier reference	See amplifier reference
Output		1 x 2 SPST in series	2 x 2 SPST in series	3 x 2 SPST in series
Low current resistive load		RS type: 2 A @ 240 VAC / 30 VDC RSL type: 0.5 A @ 50 VAC / 30 VAC	RS type: 2 A @ 240 VAC / 30 VDC RSL type: 0.5 A @ 50 VAC / 30 VAC	RS type: 2 A @ 240 VAC / 30 VDC RSL type: 0.5 A @ 50 VAC / 30 VAC
Operating frequency	Amplifier dependent	10 Hz	10 Hz	10 Hz
Degree of protection	IP67	IP40	IP40	IP40
Protection short-circuit (S)				
Reverse polarity (P)	SPT	PT	PT	PT
Transients (T)				
Housing material		PC	PC	PC
-Amplifier				
-Sensor Ø12+D11+D18	PC + ABS			
-Sensor	PC + Stainless steel			
Operating temperature	-20°C to +60°C	-20°C to +60°C	-20°C to +60°C	-20°C to +60°C
LED colour		Yellow	Yellow	Yellow
Approvals/Marks	CE - UL325 - UL508	CE - UL325 - UL508	CE - UL325 - UL508	CE - UL325 - UL508
Remarks	C = Pigtail connector version			
Optical angle (degrees)	±5			

Photoelectric sensors

Sensors for amplifiers

Types	MOF..	MOF.. ATEX	MNF..	MDF..
Connections	10 m cable	Terminals	Terminals	Terminals
				

Dimensions (mm)	Ø 10 x 42	Ø 10 x 42	Ø 20 x 80	Ø 13.5 x 55
-----------------	-----------	-----------	-----------	-------------

Through-beam emitter

Sensing distance (Sn)	20 m	20 m		
Max. ±2° optical angle	MOFT20 MOFT20-M12-2	MOFT20AX MOFT20-M12-2AX		
Sensing distance (Sn)	50 m			
Max. ±2° optical angle	MOFT50 MOFT50-M12-2			
Sensing distance (Sn)	20 m	20 m		
Max. ±5° optical angle	MOFT20-5 MOFT20-M12-5	MOFT20-5AX MOFT20-M12-5AX		
Sensing distance (Sn)	20 m	20 m	15 m	30 m
Max. ±8° optical angle	MOFT20-8 MOFT20-M12-8 MOFT20-M14-8	MOFT20-8AX MOFT20-M12-8AX MOFT20-M14-8AX	MNFT15	MDFT30

Through-beam receiver

Operating frequency	Amplifier dependent	Amplifier dependent	Amplifier dependent	Amplifier dependent
Sensing distance (Sn)	See emitter	See emitter	See emitter	See emitter
Max. ±2° optical angle	MOFR MOFR-M12-2	MOFRAX MOFR-M12-2AX		
Max. ±5° optical angle	MOFR-5 MOFR-M12-5	MOFR-5AX MOFR-M12-5AX		
Max. ±8° optical angle	MOFR-8 MOFR-M12-8 MOFR-M14-8	MOFR-8AX MOFR-M12-8AX MOFR-M14-8AX	MNFR15	MDFR30

General specifications

Rated operating voltage	Powered by Amplifier	Powered by Amplifier	Powered by Amplifier	Powered by Amplifier
Output	On Amplifier	On Amplifier	On Amplifier	On Amplifier
Operating frequency	See Amplifier type: S142.. - S143.. - PAM..	See Amplifier type: S142.. - S143.. - PAM..	See Amplifier type: S142.. - S143.. - PAM..	See Amplifier type: S142.. - S143.. - PAM..
Degree of protection	IP66 - IP67	IP66 - IP67	IP67	IP67
Protection short-circuit (S)				
Reverse polarity (P)	SPT	SPT	SPT	SPT
Transients (T)				
Housing material sensor	Ø10: PC M14 + M14: PC + SS	Ø10: PC M14 + M14: PC + SS	PC M14 + M14: PC + SS	Acetal, glass reinforced
Operating temperature	-20°C to +60°C	-20°C to +60°C	-20°C to +60°C	-20°C to +60°C
LED colour	None	None	None	None
Approvals/Marks	CE	CE - ATEX	CE	CE

Photoelectric sensors

Types

Amplifiers for sensors

Connections

1 1-pole plug

1 1-pole plug

1 1-pole plug



Dimensions (mm)	35 x 80 x 81.5	35 x 80 x 81.5	35 x 80 x 81.5
Description	Standard amplifier with Sensor diagnostics and adjustable sensing distance	As S142A but with adjustable time delay	As S142A but with Master / Slave function for high neighbour immunity





Amplifier references

1 x SPDT relay	S142ARNN924	S142BRNN924	
1 x NPN output	S142ARNN024	S142BRNN024	
1 x NPN alarm output	S142ARNN115 S142ARNN230	S142BRNN115 S142BRNN230	
1 x SPDT relay	S142ARNT924	S142BRNT924	
1 x NPN output or alarm	S142ARNT024		
1 x Emitter mute input	S142ARNT115 S142ARNT230	S142BRNT115 S142BRNT230	
1 x PNP output	S142APPT924	S142BPPT924	
1 x PNP alarm output	S142APPT115	S142BPPT115	
1 x Emitter mute input	S142APPT230	S142BPPT230	
1 x SPDT relay			S142CRXA924
A - Auto distance adjustment			S142CRXA115 S142CRXA230
M - Manual distance adjustment			S142CRXM924 S142CRXM115 S142CRXM230

General specifications

Rated operating voltage			
924	24 VAC/DC	24 VAC/DC	24 VAC/DC
115	115 VAC	115 VAC	115 VAC
230	230 VAC	230 VAC	230 VAC
Relay load current resistive load	10 A @ 250 VAC / 25 VDC SPD	10 A @ 250 VAC / 25 VDC SPD	10 A @ 250 VAC / 25 VDC SPD
Transistor load current	100 mA 40 VDC	100 mA 40 VDC	
Operation frequency	20 Hz	20 Hz, no timer	15 Hz @ 2 systems 4 Hz @ 6 systems
Degree of protection	IP20	IP20	IP20
Protection short-circuit (S)			
Reverse polarity (P)	SPT	SPT	S
Transients (T)			
Housing material	Noryl SE1, Light grey	Noryl SE1, Light grey	Noryl SE1, Light grey
Operating temperature	-20°C to +50°C	-20°C to +50°C	-20°C to +50°C
Approvals/Marks	CE - UL - CSA	CE - UL - CSA	CE - UL - CSA

Photoelectric sensors

Types	S1430 UAP..	S1430 RAL..	S1430 ROS..	PAM...
Connections	11-pole plug	11-pole plug	11-pole plug	Terminals
				
Dimensions (mm)	35 x 80 x 81.5	35 x 80 x 81.5	35 x 80 x 81.5	2, 3, 4, 5, 6 DIN housing
Description	3 inputs 3 transistor outputs	3 inputs 3 transistor outputs	3 inputs 3 double relay outputs	2-4-6-8 or 10 channels modular system
Amplifier references				
12-30 VAC/DC $\pm 15\%$	S1430UAP912			
15-30 VAC/DC $\pm 10\%$		S1430RAL915	S1430ROS915	
No. of channels				2 channels
- NPN output, NO				PAM02AN3ANO/NC
- PNP output, NO				PAM02AN3APO/PC
No. of channels				4 channels
- NPN output, NO				PAM04AN3ANO/NC
- PNP output, NO				PAM04AN3APO/PC
No. of channels				6 channels
- NPN output, NO				PAM06AN3ANO/NC
- PNP output, NO				PAM06AN3APO/PC
Extension modules references				
No. of channels				2 channels
- NPN output, NO				PAM02CN3ANO
- NPN output, NC				PAM02CN3ANC
- PNP output, NO				PAM02CN3APO
- PNP output, NC				PAM02CN3APC
No. of channels				4 channels
- NPN output, NO				PAM04CN3ANO
- NPN output, NC				PAM04CN3ANC
- PNP output, NO				PAM04CN3APO
- PNP output, NC				PAM04CN3APC
General specifications				
Rated operating voltage	See Amplifier type	See Amplifier type	See Amplifier type	18 - 33 VDC
Output	3 x Transistor NPN/PNP/NO/NC	3 x SPST	3 x SPST	One output per channel
Load current resistive load	100 mA, 40 VDC, NPN	1.5 A @ 100 VAC / 30 VDC	1.5 A @ 100 VAC / 30 VDC	20 mA, 33 VDC, NPN / PNP 8 A @ 250 VAC / 24 VDC SPDT resistive load
Operation frequency	16 Hz	12.5 Hz	12.5 Hz	30 Hz @ 6 channels
Degree of protection	IP20	IP20	IP20	IP20
Protection short-circuit (S)				
Reverse polarity (P)	SPT	PT	PT	SPT
Transients (T)				
Housing material	Noryl SE1, Light grey	Noryl SE1, Light grey	Noryl SE1, Light grey	
Operating temperature	-20°C to +50°C	-20°C to +50°C	-20°C to +50°C	-20°C to +50°C
LED colour	Yellow + Green + Red	Yellow + Green + Red	Yellow + Green + Red	Yellow + Green + Red
Approvals/Marks	Multiplexed system	Multiplexed system	Multiplexed system	Multiplexed system, test functions, bargraph, mute input etc.

Photoelectric sensors

Types Wireless entrapment protection device for industrial doors ESPE

Connections Main controller Subcontroller PB 11



Dimensions (mm) 35 x 35 x 125 26 x 242 x 45 Ø11 x 24.5

Description The Carlo Gavazzi main controller can control up to 4 subcontrollers This flexible Carlo Gavazzi subcontroller can handle 2 safety edges and 1 door-in-door limit switch



References

Main controller	WSM 2 B A 2 D24		
Subcontroller		WSS 2 B A 2 BAT	
Photoelectric sensor Emitter			PB 11 CNT 15 WE
Photoelectric sensor Receiver			PB 11 CNT 15 WR

General specifications

Rated operating voltage	12 - 24 VAC/DC	1 - 4 Lithium 3.6 VDC size AA batteries	From subcontroller
Supply current	< 50 mA		
Relay load current resistive load	1 A / 30 VDC 0.5 A / 30 VAC		
Communication frequency	2.4 GHz Duplex	2.4 GHz Duplex	
Response time	120 mS	120 mS	
Number of channels	16	16	
Communication distance	10 m wireless	10 m wireless	
Sensing distance			15 m
Subcontroller up-time		10 - 80 sec	
Test input	On main module		
Degree of protection	IP66	IP66	IP67
Protection short-circuit (S) Reverse polarity (P) Transients (T)	PT	P	
Housing material	ABS, Light grey	PC, Light grey	PA6 Glass reinforced
Operating temperature	-25°C to +55°C	-25°C to +55°C	-25°C to +55°C
LED colour	Green, Yellow, Red	Yellow	-
Approvals/Marks	CE - UL - FCC	CE - UL - FCC	CE - UL

Photoelectric sensors

Types	Wireless entrapment protection device for industrial gates ESPE		
Connections	Main controller	Subcontroller	PB 11
			
Dimensions (mm)	35 x 35 x 125	26 x 242 x 45	Ø11 x 24.5
Description	The Carlo Gavazzi main controller can control up to 6 subcontrollers	This flexible Carlo Gavazzi subcontroller can handle one opening safety edge and one closing edge	
References			
Main controller (N.O. 8.2 kohm output)	WSM6GAOOD24		
Main controller (N.C. output)	WSM6GACCD24		
Subcontroller	WSS2GA2BAT		
Photoelectric sensor Emitter	PB 11 CNT 15 WE		
Photoelectric sensor Receiver	PB 11 CNT 15 WR		
General specifications			
Rated operating voltage	12 - 24 VAC/DC	1 - 4 Lithium 3.6 VDC size AA batteries	From subcontroller
Supply current	< 50 mA		
Relay load current resistive load	1 A / 30 VDC 0.5 A / 30 VAC		
Communication frequency	2.4 GHz Duplex	2.4 GHz Duplex	
Response time	From 15 to 100 ms	From 15 to 100 ms	
Number of channels	16		
Communication distance	15 m wireless		
Sensing distance	2.5 m		
Subcontroller up-time	15 – 105 s, fixed time or infinite		
Test input	On main module		
Degree of protection	IP66	IP66	IP67
Protection short-circuit (S)			
Reverse polarity (P)	PT		
Transients (T)	P		
Housing material	ABS, Light grey	PC, Light grey	PA6 Glass reinforced
Operating temperature	-25°C to +55°C		
LED colour	Green, Yellow, Red	Yellow	
Approvals/Marks	CE - UL - FCC - TÜV	CE - UL - FCC - TÜV	CE - UL

Photoelectric level sensors

Integrated amplifier

Types	VP0.E.	VP ATEX	VP E.M
Connections	2 m cable	2 m cable	2 m cable
			

Dimensions (mm)	3/8" x 74	3/8" x 74	3/8" x 74
Light type	Unmodulated	Unmodulated	Unmodulated

Optical level sensor references

Operating frequency	30 Hz	30 Hz	30 Hz
Sensing dist. (Sn), Hor.	± 5 mm, fixed	± 5 mm, fixed	± 5 mm, fixed
Sensing dist. (Sn), Ver.	± 2.5 mm, fixed	± 2.5 mm, fixed	± 2.5 mm, fixed
Housing material	Polysulfone	Polysulfone	Polysulfone
NPN NO	VP02E		VP02EM
NPN NC	VP01E		VP01EM
PNP NO	VP02EP	VP02EPAX	VP02EPM
PNP NC	VP01EP	VP01EPAX	VP01EPM
Housing material	Polyamide 12	Polyamide 12	Polyamide 12
NPN NO	VP04E		VP04EM
NPN NC	VP03E		VP03EM
PNP NO	VP04EP	VP04EPAX	VP04EPM
PNP NC	VP03EP	VP03EPAX	VP03EPM
Housing material	Polysulfone		
SCR NO	VP02-110TB		
SCR NC	VP01-110TB		
SCR NO	VP02-230TB		
SCR NC	VP01-230TB		

DC-types

Rated operating voltage	10 - 40 VDC	10 - 16.8 VDC	10 - 40 VDC
Voltage drop	≤ 1.0 VDC	≤ 1.0 VDC	≤ 1.0 VDC
Off-state current	≤ 12 mA	≤ 12 mA	≤ 12 mA
Load current	< 200 mA	< 50 mA	< 200 mA

AC-types (SCR)

Rated operating voltage	110 or 230 VAC		
Voltage drop	≤ 9 VAC		
Off-state current	≤ 7 mA		
Load current	< 10 - 100 mA		

General specifications

Degree of protection	IP67	IP67	IP67
Protection short-circuit (S)			
Reverse polarity (P)	PT	PT	PT
Transients (T)			
Operating temperature	-20°C to +80°C	-20°C to +80°C	-20°C to +80°C
LED colour	Yellow	Yellow	Yellow
Pressure	10 bar @ +60°C	10 bar @ +60°C	10 bar @ +60°C
Approvals/Marks	CE	CE -  - TÜV - ATEX zone 1	CE

Photoelectric level sensors

Integrated amplifier

Types	VPA..../VPB....	VPA....-1/VPB....-1
Connections	2 m cable	M12 connector



Dimensions (mm)	3/8" x 70.5	3/8" x 90.5
Light type	Modulated	Modulated

Optical level sensor references

Operating frequency	30 Hz	30 Hz
Sensing dist. (Sn), Hor.	± 5 mm, fixed	± 5 mm, fixed
Sensing dist. (Sn), Ver.	± 2.5 mm, fixed	± 2.5 mm, fixed
Housing material	Stainless steel/polysulfone	Stainless steel/polysulfone
NPN NO+NC	VPA1MNA	VPA1MNA-1
PNP NO+NC	VPA1MPA	VPA1MPA-1
Housing material	Stainless steel and glass	Stainless steel and glass
NPN NO+NC	VPA2MNA	VPA2MNA-1
PNP NO+NC	VPA2MPA	VPA2MPA-1
Housing material	Nickel-pl. brass/polysulfone	Nickel-pl. brass/polysulfone
NPN NO+NC	VPB1MNA	VPB1MNA-1
PNP NO+NC	VPB1MPA	VPB1MPA-1
Housing material	Nickel-plated brass and glass	Nickel-plated brass and glass
NPN NO+NC	VPB2MNA	VPB2MNA-1
PNP NO+NC	VPB2MPA	VPB2MPA-1

DC-types



Rated operational voltage	10 - 40 VDC	10 - 40 VDC
Voltage drop	≤ 2.5 VDC	≤ 2.5 VDC
Off-state current	≤ 7 mA	≤ 7 mA
Load current	< 200 mA	< 200 mA

General specifications

Degree of protection	IP67	IP67
Protection short-circuit (S)		
Reverse polarity (P)	SPT	SPT
Transients (T)		
Operating temperature	-20°C to +70°C	-20°C to +70°C
LED colour	Yellow	No LED
Pressure	10 bar @ +60°C	10 bar @ +60°C
Approvals/Marks	CE	CE

Motion and presence sensors

Combined motion and presence detectors for pedestrian doors

Types	GUARDIAN 1	GUARDIAN 2
Connections	Terminal block	Terminal block
		
Dimensions (mm)	210 x 77 x 58	210 x 77 x 58
Technology	Digital video camera technology 640 x 480	Digital video camera technology 640 x 480
Door types	Straight sliding doors	Curved and straight sliding doors
Features	The Guardian sensor is a unique motion and presence detector that provides maximum safety and protection in pedestrian sliding door installations. Equipped with the latest digital video camera technology, Guardian watches over the entrance and exit area safeguarding people within, while at the same time controlling the doors. Guardian is able to ignore cross traffic, and it has a brilliant capability of self-adjusting to changes in the environment and weather conditions.	
Input specifications		
Mounting height	180 cm to 300 cm	180 cm to 300 cm
Motion zone sensing area	Height 180 cm = 246 x 204 cm Height 220 cm = 300 x 249 cm Height 300 cm = 410 x 340 cm	Height 180 cm = 246 x 204 cm Height 220 cm = 300 x 249 cm Height 300 cm = 410 x 340 cm
Presence zone sensing area	Height 180 cm = 42 cm x door width Height 220 cm = 51 cm x door width Height 300 cm = 70 cm x door width	Height 180 cm = 42 cm x door width Height 220 cm = 51 cm x door width Height 300 cm = 70 cm x door width
Maximum door radius vs. Mounting height		Height 180 cm = Radius 130 cm Height 220 cm = Radius 170 cm Height 300 cm = Radius 200 cm
Sensitivity	Adjustment in 7 steps	Adjustment in 7 steps
Presence time	7 step rotary switch: (10, 30 sec.) 1 min, 5 min (not accordance to DIN18650)	7 step rotary switch: (10, 30 sec.) 1 min, 5 min (not accordance to DIN18650)
Ambient light	10 lux - 50.000 lux	10 lux - 50.000 lux
Output specifications		
Output function	Safety and Motion Zone: relay - SPST Common relay data: 1 A DC 30 VDC 600.000 cycles @ 0.5 A, 50 VAC/30 VDC	Safety and Motion Zone: relay - SPST Common relay data: 1 A DC 30 VDC 600.000 cycles @ 0.5 A, 50 VAC/30 VDC
General specifications		
Rated operating voltage	12 - 24 VAC	12 - 24 VAC
No load supply current	Max. 230 mA	Max. 230 mA
Test input. Active high	ON > 9 VAC/VDC OFF < 6 VAC/VDC	ON > 9 VAC/VDC OFF < 6 VAC/VDC
Test input. Active low	ON < 6 VAC/VDC OFF > 9 VAC/VDC	ON < 6 VAC/VDC OFF > 9 VAC/VDC
Type of ESPE	Type 2	Type 2
Degree of protection	IP64	IP64
TÜV	In acc. with machinery directive 2006/42/EC, annex I DIN 18650-1 § 5.7.4, edition 2005 (prEN16005), EN13241-1, EN 12978	In acc. with machinery directive 2006/42/EC, annex I DIN 18650-1 § 5.7.4, edition 2005 (prEN16005), EN13241-1, EN 12978
UL-approved	cURus: UL325, CSA-C22.2 No. 247	cURus: UL325, CSA-C22.2 No. 247
Marking	CE	CE
References		
Marking	GUARDIAN 1	GUARDIAN 2

Photoelectric sensors accessories

Reflectors, rectangular



Item Number	ER100	ER840	ER681	ER686
Dimensions (mm)	100 x 100 x 9.2	84.5 x 84.5 x 9	52 x 119 x 27	55.3 x 126 x 9
Mounting (screws not incl.)	2 x M3 screws	2 x M3.5 screws	4 x M4 screws	2 x M6 screws
Reduction factor	1.2	0.96	0.92	0.92

Reflectors, rectangular

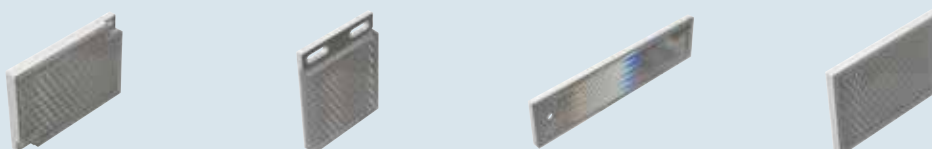

Item Number	ER4060	ER5060	ER42182	ER5080
Dimensions (mm)	60 x 41 x 8	55.5 x 61 x 8	186 x 46.5 x 8	80 x 54 x 8
Mounting (screws not incl.)	2 x M3.5 screws	2 x M4 screws	2 x M6 screws	Adhesive
Reduction factor	0.81	0.80	0.65	0.60

Reflectors, rectangular

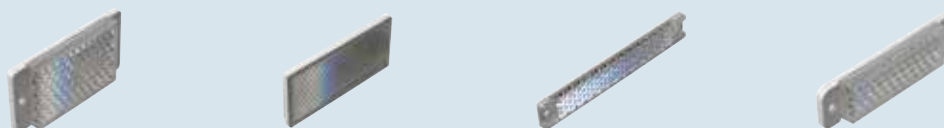

Item Number	ER483	ER8	ER665	ER530
Dimensions (mm)	32.5 x 65 x 8	82 x 37 x 5.5	18.5 x 120 x 65	19 x 72.5 x 8.4
Mounting (screws not incl.)	2 x M3.5 screws	Adhesive	2 x M4 screws	2 x M3.5 screws
Reduction factor	0.55	0.51	0.45	0.45

Reflectors, rectangular

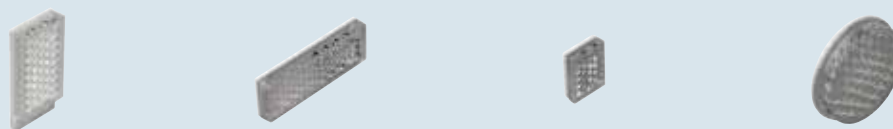

Item Number	ER390	ER1	ER640	ER692
Dimensions (mm)	23.5 x 47.5 x 8	51 x 17.5 x 5	13 x 17 x 5	Ø 35 x 5.5
Mounting (screws not incl.)	2 x M3.5 screws	Adhesive	Adhesive	Adhesive
Reduction factor	1.39	0.20	0.16	0.53

Photoelectric sensors accessories

Reflectors, cylindrical

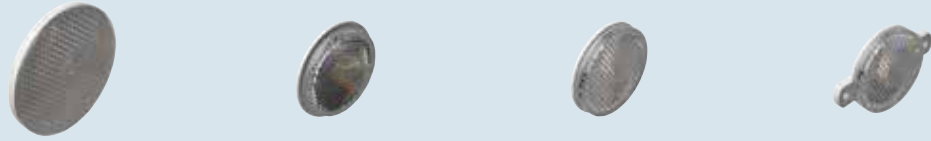

Item Number	ER4	ER460	ER420	ER423
Dimensions (mm)	Ø 84 x 7.4	Ø 46 x 6.5	Ø 42 x 6.3	Ø 41.5 x 6
Mounting (screws not incl.)	1 x M4 screw	Adhesive	Adhesive	2 x M3 screws
Reduction factor	1	0.55	0.54	0.54

Reflectors, cylindrical

Micro cube reflectors for LD32

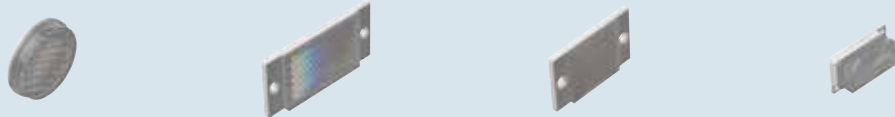

Item Number	ER689	EM 130-20	EM 120-20	EM 123-70
Dimensions (mm)	Ø 25 x 5.5	20 x 43	20 x 32	13.7 x 23
Mounting (screws not incl.)	Adhesive	2 x M3 screws	2 x M3.5 screws	2 x M2 screws
Reduction factor	0.39	1 (Micro Cube)	1 (Micro Cube)	1 (Micro Cube)

Reflectors, tape

Micro cube reflectors for LD32

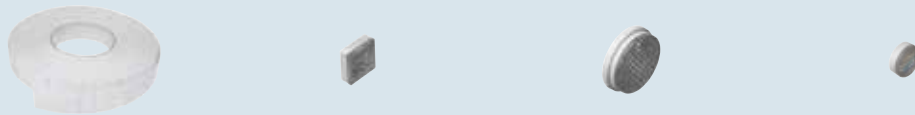

Item Number	ERT25	EM 111-40	EM 121-41	EM 110-40
Dimensions (mm)	25 mm x 45.7 m	10.5 x 10.5	Ø20	Ø10
Mounting (screws not incl.)	Adhesive			
Reduction factor	0.23 (25 x 25 mm)	1 (Micro Cube)	1 (Micro Cube)	1 (Micro Cube)

Reflectors, tape

Accessories, photoelectric sensors

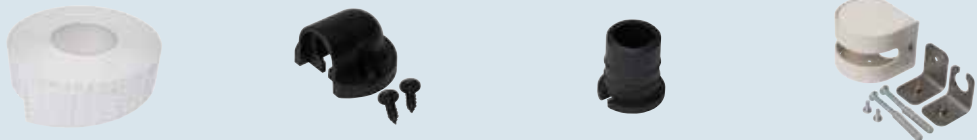

Item Number	ERT50	AMPF-MB1	AMPF-MB2	AMPF-MB3
Dimensions (mm)/Used for	50 mm x 45.7 m	MPFT15-4 & MPFR-4	MPFT15-4 & MPFR-4	MPFT15-4 & MPFR-4
Mounting (screws not incl.)	Adhesive			
Reduction factor/ Description	0.34 (50 x 50 mm)	Plastic mounting bracket for wall mounting	Adaptor for fitting to an Ø18 mm rubber profile	Metal mounting bracket for harsh environment

Photoelectric sensors accessories

Accessories, photoelectric sensors



Item Number	610DC	APA3	MB-M01	MB18A
Used for	S1430...	PA.. sensors	MOF.. sensors	M18 sensors
Description	Plug conversion	Mounting bracket in anodized aluminium	Ball mounting bracket for flexible mounting	Mounting bracket in plastic

Accessories, photoelectric sensors

Brackets



Item Number	APA18-MB1	APH18-MB1	APA-2	APB-1
Used for	PA18 sensors	PH18 sensors	PA.. sensors	PB
Description	Mounting bracket in plastic	Mounting bracket in plastic	Mounting bracket in steel, black	Mounting bracket in steel, black

Brackets



Item Number	MB02	APD32-MB3	APD30 MB1	APD30 MB2
Used for	PM	PD32 - LD32	PD.. sensors	PD.. sensors
Description	Long mounting bracket for wall mounting in steel, chromium-plated	Mounting bracket in steel, chromium-plated	Mounting bracket in steel, chromium-plated	Mounting bracket in steel, chromium-plated

Brackets





Alignment tools



Item Number	ACP50-1	APD140-LA01	APD140-LA02	APD140-TC01
Used for	PC50.. sensors	PD140.. Heavy duty infrared barrier	PD140.. Heavy duty infrared barrier	PD140.. Heavy duty infrared barrier
Description	Mounting bracket in steel, chromium-plated	Laser alignment tool	Laser alignment tool without batteries (Battery: DL1/3N, CR1/3N 3V - Lithium)	Alignment test cable





Capacitive proximity sensors, 4th Gen. TRIPLESIELD™ with IO-Link

M18-DC 4th Generation TRIPLESIELD™ with IO-Link - PBT Housing

Types	Flush mountable		Non-flush mountable	
	2 m cable	M12 connector 4-pole	2 m cable	M12 connector 4-pole
Connections				
Dimensions (mm)	M18 x 70	M18 x 85	M18 x 70	M18 x 85
Thread (mm)	M18 x 1.0 x 55	M18 x 1.0 x 55	M18 x 1.0 x 55	M18 x 1.0 x 55
Operating frequency	50 Hz	50 Hz	50 Hz	50 Hz
Sensing distance (Sn)	8 mm (adjustable 2 - 10 mm)	8 mm (adjustable 2 - 10 mm)	12 mm (adjustable 3 - 15 mm)	12 mm (adjustable 3 - 15 mm)
References				
	CA18CAF08BPA2IO	CA18CAF08BPM1IO	CA18CAN12BPA2IO	CA18CAN12BPM1IO
Characteristics flush and non-flush mountable				
Selectable function output 1	NPN, PNP or Push-Pull	NPN, PNP or Push-Pull	NPN, PNP or Push-Pull	NPN, PNP or Push-Pull
Selectable function output 2	NPN, PNP, Push-Pull, External input or External teach	NPN, PNP, Push-Pull, External input or External teach	NPN, PNP, Push-Pull, External input or External teach	NPN, PNP, Push-Pull, External input or External teach
Diagnostics	Operation hours, Power cycles, Detection cycles max. and min. Temperatures, Short-circuit, Maintenance, No of Parameter change	Operation hours, Power cycles, Detection cycles max. and min. Temperatures, Short-circuit, Maintenance, No of Parameter change	Operation hours, Power cycles, Detection cycles max. and min. Temperatures, Short-circuit, Maintenance, No of Parameter change	Operation hours, Power cycles, Detection cycles max. and min. Temperatures, Short-circuit, Maintenance, No of Parameter change
Logic functions	AND, OR, X-OR, Gated SR-FF	AND, OR, X-OR, Gated SR-FF	AND, OR, X-OR, Gated SR-FF	AND, OR, X-OR, Gated SR-FF
Timer functions	ON delay, OFF delay, ON+OFF delay and One shot	ON delay, OFF delay, ON+OFF delay and One shot	ON delay, OFF delay, ON+OFF delay and One shot	ON delay, OFF delay, ON+OFF delay and One shot
Rated operating voltage	10 - 40 VDC	10 - 40 VDC	10 - 40 VDC	10 - 40 VDC
Voltage drop	≤ 1.0 VDC	≤ 1.0 VDC	≤ 1.0 VDC	≤ 1.0 VDC
No load supply current (I _o)	≤ 20 mA	≤ 20 mA	≤ 20 mA	≤ 20 mA
"Protection short-circuit (S) Reverse polarity (P) Transients (T)"	SPT	SPT	SPT	SPT
Output current	< 200 mA	< 200 mA	< 200 mA	< 200 mA
Housing material	PBT	PBT	PBT	PBT
Operating temperature	-30°C to +85°C (120°C sensor face)	-30°C to +85°C (120°C sensor face)	-30°C to +85°C (120°C sensor face)	-30°C to +85°C (120°C sensor face)
Degree of protection	IP67, IP68, IP69K, NEMA: 1, 2, 4, 4X, 5, 6, 6P, 12	IP67, IP68, IP69K, NEMA: 1, 2, 4, 4X, 5, 6, 6P, 12	IP67, IP68, IP69K, NEMA: 1, 2, 4, 4X, 5, 6, 6P, 12	IP67, IP68, IP69K, NEMA: 1, 2, 4, 4X, 5, 6, 6P, 12
LED colour	Yellow and Green	Yellow and Green	Yellow and Green	Yellow and Green
Communication interface	IO-Link	IO-Link	IO-Link	IO-Link
Transmission type	COM2 (38,4 kBaud)	COM2 (38,4 kBaud)	COM2 (38,4 kBaud)	COM2 (38,4 kBaud)
IO-Link revision	01:01:00	01:01:00	01:01:00	01:01:00
SDCI standard	IEC 61131-9	IEC 61131-9	IEC 61131-9	IEC 61131-9
Profiles	Smart Sensor: Process Data Variable; Device Identification	Smart Sensor: Process Data Variable; Device Identification	Smart Sensor: Process Data Variable; Device Identification	Smart Sensor: Process Data Variable; Device Identification
SIO mode	Yes	Yes	Yes	Yes
Required master port type	A	A	A	A
Min. process cycle time [ms]	5	5	5	5
Approvals/Marks	CE - cULus - ECOLAB	CE - cULus - ECOLAB	CE - cULus - ECOLAB	CE - cULus - ECOLAB





Capacitive proximity sensors, 4th Gen. TRIPLESIELD™ with IO-Link

M18-DC 4th Generation TRIPLESIELD™ with IO-Link - PTFE Housing

Types	Flush mountable		Non-flush mountable	
	2 m cable	M12 connector 4-pole	2 m cable	M12 connector 4-pole
Connections				
Dimensions (mm)	M18 x 70	M18 x 70	M18 x 70	M18 x 70
Thread (mm)	M18 x 1.0 x 55	M18 x 1.0 x 55	M18 x 1.0 x 55	M18 x 1.0 x 55
Operating frequency	50 Hz	50 Hz	50 Hz	50 Hz
Sensing distance (Sn)	8 mm (adjustable 2 - 10 mm)	8 mm (adjustable 2 - 10 mm)	12 mm (adjustable 3 - 15 mm)	12 mm (adjustable 3 - 15 mm)
References				
	CA18FAF08BPA2IO	CA18FAF08BPM1IO	CA18FAN12BPA2IO	CA18FAN12BPM1IO
Characteristics flush and non-flush mountable				
Selectable function output 1	NPN, PNP or Push-Pull	NPN, PNP or Push-Pull	NPN, PNP or Push-Pull	NPN, PNP or Push-Pull
Selectable function output 2	NPN, PNP, Push-Pull, External input or External teach	NPN, PNP, Push-Pull, External input or External teach	NPN, PNP, Push-Pull, External input or External teach	NPN, PNP, Push-Pull, External input or External teach
Diagnostics	Operation hours, Power cycles, Detection cycles max. and min. Temperatures, Short-circuit, Maintenance, No of Parameter change	Operation hours, Power cycles, Detection cycles max. and min. Temperatures, Short-circuit, Maintenance, No of Parameter change	Operation hours, Power cycles, Detection cycles max. and min. Temperatures, Short-circuit, Maintenance, No of Parameter change	Operation hours, Power cycles, Detection cycles max. and min. Temperatures, Short-circuit, Maintenance, No of Parameter change
Logic functions	AND, OR, X-OR, Gated SR-FF	AND, OR, X-OR, Gated SR-FF	AND, OR, X-OR, Gated SR-FF	AND, OR, X-OR, Gated SR-FF
Timer functions	ON delay. OFF delay, ON+OFF delay and One shot	ON delay. OFF delay, ON+OFF delay and One shot	ON delay. OFF delay, ON+OFF delay and One shot	ON delay. OFF delay, ON+OFF delay and One shot
Rated operating voltage	10 - 40 VDC	10 - 40 VDC	10 - 40 VDC	10 - 40 VDC
Voltage drop	≤ 1.0 VDC	≤ 1.0 VDC	≤ 1.0 VDC	≤ 1.0 VDC
No load supply current (I _o)	≤ 20 mA	≤ 20 mA	≤ 20 mA	≤ 20 mA
Protection short-circuit (S) Reverse polarity (P) Transients (T)	SPT	SPT	SPT	SPT
Output current	< 200 mA	< 200 mA	< 200 mA	< 200 mA
Housing material	PTFE	PTFE	PTFE	PTFE
Operating temperature	-30°C to +85°C (120°C sensor face)	-30°C to +85°C (120°C sensor face)	-30°C to +85°C (120°C sensor face)	-30°C to +85°C (120°C sensor face)
Degree of protection	IP67, IP68, IP69K, NEMA: 1, 2, 4, 4X, 5, 6, 6P, 12	IP67, IP68, IP69K, NEMA: 1, 2, 4, 4X, 5, 6, 6P, 12	IP67, IP68, IP69K, NEMA: 1, 2, 4, 4X, 5, 6, 6P, 12	IP67, IP68, IP69K, NEMA: 1, 2, 4, 4X, 5, 6, 6P, 12
LED colour	Yellow and Green	Yellow and Green	Yellow and Green	Yellow and Green
Communication interface	IO-Link	IO-Link	IO-Link	IO-Link
Transmission type	COM2 (38,4 kBaud)	COM2 (38,4 kBaud)	COM2 (38,4 kBaud)	COM2 (38,4 kBaud)
IO-Link revision	1.1	1.1	1.1	1.1
SDCI standard	IEC 61131-9	IEC 61131-9	IEC 61131-9	IEC 61131-9
Profiles	Smart Sensor: Process Data Variable; Device Identification	Smart Sensor: Process Data Variable; Device Identification	Smart Sensor: Process Data Variable; Device Identification	Smart Sensor: Process Data Variable; Device Identification
SIO mode	Yes	Yes	Yes	Yes
Required master port type	A	A	A	A
Min. process cycle time [ms]	5	5	5	5
Approvals/Marks	CE - cULus - ECOLAB	CE - cULus - ECOLAB	CE - cULus - ECOLAB	CE - cULus - ECOLAB

Capacitive proximity sensors, 4th Gen. TRIPLESIELD™ with IO-Link

M18-DC 4th Generation TRIPLESIELD™ with IO-Link - PBT and AISI316 Housing

Types	Flush mountable		Non-flush mountable	
Connections	2 m cable	M12 connector 4-pole	2 m cable	M12 connector 4-pole
				
Dimensions (mm)	M18 x 70	M18 x 70	M18 x 70	M18 x 70
Thread (mm)	M18 x 1.0 x 55	M18 x 1.0 x 47	M18 x 1.0 x 55	M18 x 1.0 x 47
Operating frequency	50 Hz	50 Hz	50 Hz	50 Hz
Sensing distance (Sn)	8 mm (adjustable 2 - 10 mm)	8 mm (adjustable 2 - 10 mm)	12 mm (adjustable 3 - 15 mm)	12 mm (adjustable 3 - 15 mm)

References

CA18EAF08BPA2IO

CA18EAF08BPM1IO

CA18EAN12BPA2IO

CA18EAN12BPM1IO

Characteristics flush and non-flush mountable

Selectable function output 1	NPN, PNP or Push-Pull	NPN, PNP or Push-Pull	NPN, PNP or Push-Pull	NPN, PNP or Push-Pull
Selectable function output 2	NPN, PNP, Push-Pull, External input or External teach	NPN, PNP, Push-Pull, External input or External teach	NPN, PNP, Push-Pull, External input or External teach	NPN, PNP, Push-Pull, External input or External teach
Diagnostics	Operation hours, Power cycles, Detection cycles max. and min. Temperatures, Short-circuit, Maintenance, No of Parameter change	Operation hours, Power cycles, Detection cycles max. and min. Temperatures, Short-circuit, Maintenance, No of Parameter change	Operation hours, Power cycles, Detection cycles max. and min. Temperatures, Short-circuit, Maintenance, No of Parameter change	Operation hours, Power cycles, Detection cycles max. and min. Temperatures, Short-circuit, Maintenance, No of Parameter change
Logic functions	AND, OR, X-OR, Gated SR-FF	AND, OR, X-OR, Gated SR-FF	AND, OR, X-OR, Gated SR-FF	AND, OR, X-OR, Gated SR-FF
Timer functions	ON delay. OFF delay, ON+OFF delay and One shot	ON delay. OFF delay, ON+OFF delay and One shot	ON delay. OFF delay, ON+OFF delay and One shot	ON delay. OFF delay, ON+OFF delay and One shot
Rated operating voltage	10 - 40 VDC	10 - 40 VDC	10 - 40 VDC	10 - 40 VDC
Voltage drop	≤ 1.0 VDC	≤ 1.0 VDC	≤ 1.0 VDC	≤ 1.0 VDC
No load supply current (I _o)	≤ 20 mA	≤ 20 mA	≤ 20 mA	≤ 20 mA
Protection short-circuit (S) Reverse polarity (P) Transients (T)	SPT	SPT	SPT	SPT
Output current	< 200 mA	< 200 mA	< 200 mA	< 200 mA
Housing material	Body in AISI316L, Front in PBT	Body in AISI316L, Front in PBT	Body in AISI316L, Front in PBT	Body in AISI316L, Front in PBT
Operating temperature	-30°C to +85°C (120°C sensor face)	-30°C to +85°C (120°C sensor face)	-30°C to +85°C (120°C sensor face)	-30°C to +85°C (120°C sensor face)
Degree of protection	IP67, IP68, IP69K, NEMA: 1, 2, 4, 4X, 5, 6, 6P, 12	IP67, IP68, IP69K, NEMA: 1, 2, 4, 4X, 5, 6, 6P, 12	IP67, IP68, IP69K, NEMA: 1, 2, 4, 4X, 5, 6, 6P, 12	IP67, IP68, IP69K, NEMA: 1, 2, 4, 4X, 5, 6, 6P, 12
LED colour	Yellow and Green	Yellow and Green	Yellow and Green	Yellow and Green
Communication interface	IO-Link	IO-Link	IO-Link	IO-Link
Transmission type	COM2 (38,4 kBaud)	COM2 (38,4 kBaud)	COM2 (38,4 kBaud)	COM2 (38,4 kBaud)
IO-Link revision	1.1	1.1	1.1	1.1
SDCI standard	IEC 61131-9	IEC 61131-9	IEC 61131-9	IEC 61131-9
Profiles	Smart Sensor: Process Data Variable; Device Identification	Smart Sensor: Process Data Variable; Device Identification	Smart Sensor: Process Data Variable; Device Identification	Smart Sensor: Process Data Variable; Device Identification
SIO mode	Yes	Yes	Yes	Yes
Required master port type	A	A	A	A
Min. process cycle time [ms]	5	5	5	5
Approvals/Marks	CE - cULus - ECOLAB	CE - cULus - ECOLAB	CE - cULus - ECOLAB	CE - cULus - ECOLAB





Capacitive proximity sensors, 4th Gen. TRIPLESIELD™ with IO-Link

M30-DC 4th Generation TRIPLESIELD™ with IO-Link - PBT Housing

Types	Flush mountable		Non-flush mountable	
	2 m cable	M12 connector	2 m cable	M12 connector
Connections	2 m cable	M12 connector	2 m cable	M12 connector
				
Dimensions (mm)	M30 x 81	M30 x 74	M30 x 81	M30 x 74
Thread (mm)	M30 x 1.5 x 59.5	M30 x 1.5 x 59.5	M30 x 1.5 x 45.5	M30 x 1.5 x 45.5
Operating frequency	50 Hz	50 Hz	50 Hz	50 Hz
Sensing distance (Sn)	16 mm (adjustable 2 - 20 mm)	16 mm (adjustable 2 - 20 mm)	25 mm (adjustable 4 - 30 mm)	25 mm (adjustable 4 - 30 mm)
References				
	CA30CAF16BPA2IO	CA30CAF16BPM1IO	CA30CAN25BPA2IO	CA30CAN25BPM1IO
Characteristics flush and non-flush mountable				
Selectable function output 1	NPN, PNP or Push-Pull	NPN, PNP or Push-Pull	NPN, PNP or Push-Pull	NPN, PNP or Push-Pull
Selectable function output 2	NPN, PNP, Push-Pull, External input or External teach	NPN, PNP, Push-Pull, External input or External teach	NPN, PNP, Push-Pull, External input or External teach	NPN, PNP, Push-Pull, External input or External teach
Diagnostics	Operation hours, Power cycles, Detection cycles max. and min. Temperatures, Short-circuit, Maintenance, No of Parameter change	Operation hours, Power cycles, Detection cycles max. and min. Temperatures, Short-circuit, Maintenance, No of Parameter change	Operation hours, Power cycles, Detection cycles max. and min. Temperatures, Short-circuit, Maintenance, No of Parameter change	Operation hours, Power cycles, Detection cycles max. and min. Temperatures, Short-circuit, Maintenance, No of Parameter change
Logic functions	AND, OR, X-OR, Gated SR-FF	AND, OR, X-OR, Gated SR-FF	AND, OR, X-OR, Gated SR-FF	AND, OR, X-OR, Gated SR-FF
Timer functions	ON delay. OFF delay, ON+OFF delay and One shot	ON delay. OFF delay, ON+OFF delay and One shot	ON delay. OFF delay, ON+OFF delay and One shot	ON delay. OFF delay, ON+OFF delay and One shot
Rated operating voltage	10 - 40 VDC	10 - 40 VDC	10 - 40 VDC	10 - 40 VDC
Voltage drop	≤ 1.0 VDC	≤ 1.0 VDC	≤ 1.0 VDC	≤ 1.0 VDC
No load supply current (I _o)	≤ 20 mA	≤ 20 mA	≤ 20 mA	≤ 20 mA
Protection short-circuit (S) Reverse polarity (P) Transients (T)	SPT	SPT	SPT	SPT
Output current	< 200 mA	< 200 mA	< 200 mA	< 200 mA
Housing material	PBT	PBT	PBT	PBT
Operating temperature	-30°C to +85°C (120°C sensor face)	-30°C to +85°C (120°C sensor face)	-30°C to +85°C (120°C sensor face)	-30°C to +85°C (120°C sensor face)
Degree of protection	IP67, IP68, IP69K, NEMA:1,2,4,4X,5,6,6P,12	IP67, IP68, IP69K, NEMA:1,2,4,4X,5,6,6P,12	IP67, IP68, IP69K, NEMA:1,2,4,4X,5,6,6P,12	IP67, IP68, IP69K, NEMA:1,2,4,4X,5,6,6P,12
LED colour	Yellow and Green	Yellow and Green	Yellow and Green	Yellow and Green
Communication interface	IO-Link	IO-Link	IO-Link	IO-Link
Transmission type	COM2 (38,4 kBaud)	COM2 (38,4 kBaud)	COM2 (38,4 kBaud)	COM2 (38,4 kBaud)
IO-Link revision	1.1	1.1	1.1	1.1
SDCI standard	IEC 61131-9	IEC 61131-9	IEC 61131-9	IEC 61131-9
Profiles	Smart Sensor: Process Data Variable; Device Identification	Smart Sensor: Process Data Variable; Device Identification	Smart Sensor: Process Data Variable; Device Identification	Smart Sensor: Process Data Variable; Device Identification
SIO mode	Yes	Yes	Yes	Yes
Required master port type	A	A	A	A
Min. process cycle time [ms]	5	5	5	5
Approvals/Marks	CE - cULus - ECOLAB	CE - cULus - ECOLAB	CE - cULus - ECOLAB	CE - cULus - ECOLAB



Capacitive proximity sensors, 4th Gen. TRIPLESIELD™ with IO-Link

M30-DC 4th Generation TRIPLESIELD™ with IO-Link - PTFE Housing

Types	Flush mountable		Non-flush mountable	
	2 m cable	M12 connector	2 m cable	M12 connector
Connections	2 m cable	M12 connector	2 m cable	M12 connector
				
Dimensions (mm)	M30 x 61	M30 x 61	M30 x 61	M30 x 61
Thread (mm)	M30 x 1.5 x 59.5	M30 x 1.5 x 59.5	M30 x 1.5 x 45.5	M30 x 1.5 x 45.5
Operating frequency	50 Hz	50 Hz	50 Hz	50 Hz
Sensing distance (Sn)	16 mm (adjustable 2 - 20 mm)	16 mm (adjustable 2 - 20 mm)	25 mm (adjustable 4 - 30 mm)	25 mm (adjustable 4 - 30 mm)
References				
	CA30FAF16BPA2IO	CA30FAF16BPM1IO	CA30FAN25BPA2IO	CA30FAN25BPM1IO
Characteristics flush and non-flush mountable				
Selectable function output 1	NPN, PNP or Push-Pull	NPN, PNP or Push-Pull	NPN, PNP or Push-Pull	NPN, PNP or Push-Pull
Selectable function output 2	NPN, PNP, Push-Pull, External input or External teach	NPN, PNP, Push-Pull, External input or External teach	NPN, PNP, Push-Pull, External input or External teach	NPN, PNP, Push-Pull, External input or External teach
Diagnostics	Operation hours, Power cycles, Detection cycles max. and min. Temperatures, Short-circuit, Maintenance, No of Parameter change	Operation hours, Power cycles, Detection cycles max. and min. Temperatures, Short-circuit, Maintenance, No of Parameter change	Operation hours, Power cycles, Detection cycles max. and min. Temperatures, Short-circuit, Maintenance, No of Parameter change	Operation hours, Power cycles, Detection cycles max. and min. Temperatures, Short-circuit, Maintenance, No of Parameter change
Logic functions	AND, OR, X-OR, Gated SR-FF	AND, OR, X-OR, Gated SR-FF	AND, OR, X-OR, Gated SR-FF	AND, OR, X-OR, Gated SR-FF
Timer functions	ON delay, OFF delay, ON+OFF delay and One shot	ON delay, OFF delay, ON+OFF delay and One shot	ON delay, OFF delay, ON+OFF delay and One shot	ON delay, OFF delay, ON+OFF delay and One shot
Rated operating voltage	10 - 40 VDC	10 - 40 VDC	10 - 40 VDC	10 - 40 VDC
Voltage drop	≤ 1.0 VDC	≤ 1.0 VDC	≤ 1.0 VDC	≤ 1.0 VDC
No load supply current (I _o)	≤ 20 mA	≤ 20 mA	≤ 20 mA	≤ 20 mA
Protection short-circuit (S) Reverse polarity (P) Transients (T)	SPT	SPT	SPT	SPT
Output current	< 200 mA	< 200 mA	< 200 mA	< 200 mA
Housing material	PTFE	PTFE	PTFE	PTFE
Operating temperature	-30°C to +85°C (120°C sensor face)	-30°C to +85°C (120°C sensor face)	-30°C to +85°C (120°C sensor face)	-30°C to +85°C (120°C sensor face)
Degree of protection	IP67, IP68, IP69K, NEMA:1,2,4,4X,5,6,6P,12	IP67, IP68, IP69K, NEMA:1,2,4,4X,5,6,6P,12	IP67, IP68, IP69K, NEMA:1,2,4,4X,5,6,6P,12	IP67, IP68, IP69K, NEMA:1,2,4,4X,5,6,6P,12
LED colour	Yellow and Green	Yellow and Green	Yellow and Green	Yellow and Green
Communication interface	IO-Link	IO-Link	IO-Link	IO-Link
Transmission type	COM2 (38,4 kBaud)	COM2 (38,4 kBaud)	COM2 (38,4 kBaud)	COM2 (38,4 kBaud)
IO-Link revision	1.1	1.1	1.1	1.1
SDCI standard	IEC 61131-9	IEC 61131-9	IEC 61131-9	IEC 61131-9
Profiles	Smart Sensor: Process Data Variable; Device Identification	Smart Sensor: Process Data Variable; Device Identification	Smart Sensor: Process Data Variable; Device Identification	Smart Sensor: Process Data Variable; Device Identification
SIO mode	Yes	Yes	Yes	Yes
Required master port type	A	A	A	A
Min. process cycle time [ms]	5	5	5	5
Approvals/Marks	CE - cULus - ECOLAB	CE - cULus - ECOLAB	CE - cULus - ECOLAB	CE - cULus - ECOLAB

Capacitive proximity sensors, 4th Gen. TRIPLESIELD™ with IO-Link

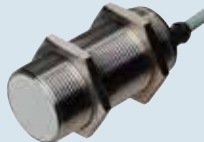
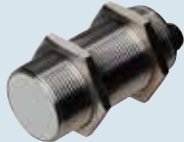
M30-DC 4th Generation TRIPLESIELD™ with IO-Link - PBT and AISI316 Housing

Types	Flush mountable		Non-flush mountable	
	2 m cable	M12 connector	2 m cable	M12 connector
Connections				
Dimensions (mm)	M30 x 61	M30 x 61	M30 x 61	M30 x 61
Thread (mm)	M30 x 1.5 x 59.5	M30 x 1.5 x 59.5	M30 x 1.5 x 45.5	M30 x 1.5 x 45.5
Operating frequency	50 Hz	50 Hz	50 Hz	50 Hz
Sensing distance (Sn)	16 mm (adjustable 2 - 20 mm)	16 mm (adjustable 2 - 20 mm)	25 mm (adjustable 4 - 30 mm)	25 mm (adjustable 4 - 30 mm)
References				
	CA30EAF16BPA2IO	CA30EAF16BPM1IO	CA30EAN25BPA2IO	CA30EAN25BPM1IO
Characteristics flush and non-flush mountable				
Selectable function output 1	NPN, PNP or Push-Pull	NPN, PNP or Push-Pull	NPN, PNP or Push-Pull	NPN, PNP or Push-Pull
Selectable function output 2	NPN, PNP, Push-Pull, External input or External teach	NPN, PNP, Push-Pull, External input or External teach	NPN, PNP, Push-Pull, External input or External teach	NPN, PNP, Push-Pull, External input or External teach
Diagnostics	Operation hours, Power cycles, Detection cycles max. and min. Temperatures, Short-circuit, Maintenance, No of Parameter change	Operation hours, Power cycles, Detection cycles max. and min. Temperatures, Short-circuit, Maintenance, No of Parameter change	Operation hours, Power cycles, Detection cycles max. and min. Temperatures, Short-circuit, Maintenance, No of Parameter change	Operation hours, Power cycles, Detection cycles max. and min. Temperatures, Short-circuit, Maintenance, No of Parameter change
Logic functions	AND, OR, X-OR, Gated SR-FF	AND, OR, X-OR, Gated SR-FF	AND, OR, X-OR, Gated SR-FF	AND, OR, X-OR, Gated SR-FF
Timer functions	ON delay. OFF delay, ON+OFF delay and One shot	ON delay. OFF delay, ON+OFF delay and One shot	ON delay. OFF delay, ON+OFF delay and One shot	ON delay. OFF delay, ON+OFF delay and One shot
Rated operating voltage	10 - 40 VDC	10 - 40 VDC	10 - 40 VDC	10 - 40 VDC
Voltage drop	≤ 1.0 VDC	≤ 1.0 VDC	≤ 1.0 VDC	≤ 1.0 VDC
No load supply current (I _o)	≤ 20 mA	≤ 20 mA	≤ 20 mA	≤ 20 mA
Protection short-circuit (S) Reverse polarity (P) Transients (T)	SPT	SPT	SPT	SPT
Output current	< 200 mA	< 200 mA	< 200 mA	< 200 mA
Housing material	Body in AISI316L, Front in PBT	Body in AISI316L, Front in PBT	Body in AISI316L, Front in PBT	Body in AISI316L, Front in PBT
Operating temperature	-30°C to +85°C (120°C sensor face)	-30°C to +85°C (120°C sensor face)	-30°C to +85°C (120°C sensor face)	-30°C to +85°C (120°C sensor face)
Degree of protection	IP67, IP68, IP69K, NEMA:1,2,4,4X,5,6,6P,12	IP67, IP68, IP69K, NEMA:1,2,4,4X,5,6,6P,12	IP67, IP68, IP69K, NEMA:1,2,4,4X,5,6,6P,12	IP67, IP68, IP69K, NEMA:1,2,4,4X,5,6,6P,12
LED colour	Yellow and Green	Yellow and Green	Yellow and Green	Yellow and Green
Communication interface	IO-Link	IO-Link	IO-Link	IO-Link
Transmission type	COM2 (38,4 kBaud)	COM2 (38,4 kBaud)	COM2 (38,4 kBaud)	COM2 (38,4 kBaud)
IO-Link revision	1.1	1.1	1.1	1.1
SDCI standard	IEC 61131-9	IEC 61131-9	IEC 61131-9	IEC 61131-9
Profiles	Smart Sensor: Process Data Variable; Device Identification	Smart Sensor: Process Data Variable; Device Identification	Smart Sensor: Process Data Variable; Device Identification	Smart Sensor: Process Data Variable; Device Identification
SIO mode	Yes	Yes	Yes	Yes
Required master port type	A	A	A	A
Min. process cycle time [ms]	5	5	5	5
Approvals/Marks	CE - cULus - ECOLAB	CE - cULus - ECOLAB	CE - cULus - ECOLAB	CE - cULus - ECOLAB

Capacitive proximity sensors, TRIPLESIELD™

Types

M18-AC TRIPLESIELD™

Connections

2 m cable

M12 connector

Flush mountable



Dimensions (mm)

M18 x 71.5

M18 x 83.5

Thread (mm)

M18 x 1 x 46.5

M18 x 1 x 46.5

Operating frequency

10 Hz

10 Hz

Sensing distance (Sn)

3 - 8 mm (adjustable)

3 - 8 mm (adjustable)

References

Thyristor (SCR) NO

CA18CLF08TO

CA18CLF08TOM6

Thyristor (SCR) NC

CA18CLF08TC

CA18CLF08TCM6

Non-flush mountable

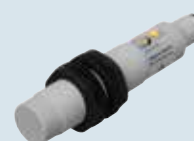

Dimensions (mm)

M18 x 79.5

M18 x 91.5

Thread (mm)

M18 x 1 x 46.5

M18 x 1 x 46.5

Operating frequency

10 Hz

10 Hz

Sensing distance (Sn)

3 - 12 mm (adjustable)

3 - 12 mm (adjustable)

References

Thyristor (SCR) NO

CA18CLN12TO

CA18CLN12TOM6

Thyristor (SCR) NC

CA18CLN12TC

CA18CLN12TCM6

Characteristics flush and non-flush mountable

Rated operating voltage

20 - 250 VAC

20 - 250 VAC

Voltage drop

≤ 10 VAC

≤ 10 VAC

Degree of protection

IP67

IP67

Protection short-circuit (S)

T

T

Reverse polarity (P)

Transients (T)

Output current

< 500 mA

< 500 mA

Housing material

Thermoplastic polyester

Thermoplastic polyester

Operating temperature

-25°C to +80°C

-25°C to +80°C

LED colour

Yellow

Yellow

Approvals/Marks

CE - UL - CSA





CE - UL - CSA

Capacitive proximity sensors, 4th Generation TRIPLESIELD™

Types	M18-DC 4 th Generation TRIPLESIELD™ Flush mountable		M18-DC 4 th Generation TRIPLESIELD™ Non-flush mountable	
	2 m cable	M12 connector	2 m cable	M12 connector
				
Dimensions (mm)	M18 x 70	M18 x 85	M18 x 70	M18 x 85
Thread (mm)	M18 x 1.0 x 55	M18 x 1.0 x 55	M18 x 1.0 x 55	M18 x 1.0 x 55
Operating frequency	50 Hz	50 Hz	50 Hz	50 Hz
Sensing distance (Sn)	8 mm (adjustable 2 - 10 mm)	8 mm (adjustable 2 - 10 mm)	12 mm (adjustable 3 - 15 mm)	12 mm (adjustable 3 - 15 mm)
References				
Standard				
NPN - NO and NC	CA18CAF08NA	CA18CAF08NAM1	CA18CAN12NA	CA18CAN12NAM1
PNP - NO and NC	CA18CAF08PA	CA18CAF08PAM1	CA18CAN12PA	CA18CAN12PAM1
Characteristics flush and non-flush mountable				
Rated operating voltage	10 - 40 VDC	10 - 40 VDC	10 - 40 VDC	10 - 40 VDC
Voltage drop	≤ 2.0 VDC	≤ 2.0 VDC	≤ 2.0 VDC	≤ 2.0 VDC
Degree of protection	IP67, IP68, IP69K	IP67, IP68, IP69K	IP67, IP68, IP69K	IP67, IP68, IP69K
Protection short-circuit (S) Reverse polarity (P) Transients (T)	SPT	SPT	SPT	SPT
Output current	< 200 mA	< 200 mA	< 200 mA	< 200 mA
Housing material	PBT	PBT	PBT	PBT
Operating temperature	-30°C to +85°C	-30°C to +85°C	-30°C to +85°C	-30°C to +85°C
LED colour	Yellow and Green	Yellow and Green	Yellow and Green	Yellow and Green
Approvals/Marks	CE - cULus - ECOLAB	CE - cULus - ECOLAB	CE - cULus - ECOLAB	CE - cULus - ECOLAB

Capacitive proximity sensors, 4th Generation TRIPLESIELD™

M30-DC 4th Generation TRIPLESIELD™

Types	Flush mountable		Non-flush mountable	
	2 m cable	M12 connector	2 m cable	M12 connector
Connections				
Dimensions (mm)	M30 x 81	M30 x 74	M30 x 81	M30 x 74
Thread (mm)	M30 x 1.5 x 59.5	M30 x 1.5 x 59.5	M30 x 1.5 x 45.5	M30 x 1.5 x 45.5
Operating frequency	50 Hz	50 Hz	50 Hz	50 Hz
Sensing distance (Sn)	16 mm (adjustable 2 - 20 mm)	16 mm (adjustable 2 - 20 mm)	25 mm (adjustable 4 - 30 mm)	25 mm (adjustable 4 - 30 mm)
References				
Standard				
NPN - NO and NC	CA30CAF16NA	CA30CAF16NAM1	CA30CAN25NA	CA30CAN25NAM1
PNP - NO and NC	CA30CAF16PA	CA30CAF16PAM1	CA30CAN25PA	CA30CAN25PAM1
Characteristics flush and non-flush mountable				
Rated operating voltage	10 - 40 VDC	10 - 40 VDC	10 - 40 VDC	10 - 40 VDC
Voltage drop	≤ 2.0 VDC	≤ 2.0 VDC	≤ 2.0 VDC	≤ 2.0 VDC
Degree of protection	IP67, IP68, IP69K	IP67, IP68, IP69K	IP67, IP68, IP69K	IP67, IP68, IP69K
Protection short-circuit (S)				
Reverse polarity (P)	SPT	SPT	SPT	SPT
Transients (T)				
Output current	< 200 mA	< 200 mA	< 200 mA	< 200 mA
Housing material	PBT	PBT	PBT	PBT
Operating temperature	-30°C to +85°C	-30°C to +85°C	-30°C to +85°C	-30°C to +85°C
LED colour	Yellow and Green	Yellow and Green	Yellow and Green	Yellow and Green
Approvals/Marks	CE - cULus - ECOLAB	CE - cULus - ECOLAB	CE - cULus - ECOLAB	CE - cULus - ECOLAB

Capacitive proximity sensors, TRIPLESIELD™

Types M30-AC TRIPLESIELD™

Connections 2 m cable M12 connector 2 m cable M12 connector

Flush mountable



Dimensions (mm)	M30 x 63.6	M30 x 63.6	M30 x 63.6	M30 x 63.6
Thread (mm)	M30 x 1.5 x 50	M30 x 1.5 x 50	M30 x 1.5 x 50	M30 x 1.5 x 50
Operating frequency	10 Hz	10 Hz	10 Hz	10 Hz
Sensing distance (Sn)	2 - 16 mm (adjustable)	2 - 16 mm (adjustable)	2 - 16 mm (adjustable)	2 - 16 mm (adjustable)

References

Thyristor (SCR) NO or NC	EC3016TBAPL	EC3016TBAPL-6	EC3016TBASL	EC3016TBASL-6
--------------------------	-------------	---------------	-------------	---------------

Non-flush mountable



Dimensions (mm)	M30 x 75.6	M30 x 75.6	M30 x 75.6	M30 x 75.6
Thread (mm)	M30 x 1.5 x 50	M30 x 1.5 x 50	M30 x 1.5 x 50	M30 x 1.5 x 50
Operating frequency	10 Hz	10 Hz	10 Hz	10 Hz
Sensing distance (Sn)	4 - 25 mm (adjustable)	4 - 25 mm (adjustable)	4 - 25 mm (adjustable)	4 - 25 mm (adjustable)



References

Thyristor (SCR) NO or NC	EC3025TBAPL	EC3025TBAPL-6	EC3025TBASL	EC3025TBASL-6
--------------------------	-------------	---------------	-------------	---------------

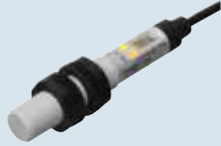

Characteristics flush and non-flush mountable

Rated operating voltage	20 - 250 VAC	20 - 250 VAC	20 - 250 VAC	20 - 250 VAC
Voltage drop	< 10 VAC	< 10 VAC	< 10 VAC	< 10 VAC
Degree of protection	IP67	IP67	IP67	IP67
Protection short-circuit (S)	T	T	T	T
Reverse polarity (P)				
Transients (T)				
Output current	< 500 mA	< 500 mA	< 500 mA	< 500 mA
Housing material	Thermoplastic polyester	Thermoplastic polyester	Stainless steel	Stainless steel
Operating temperature	-25°C to +80°C	-25°C to +80°C	-25°C to +80°C	-25°C to +80°C
LED colour	Yellow	Yellow	Yellow	Yellow
Approvals/Marks	CE - UL - CSA	CE - UL - CSA	CE - UL - CSA	CE - UL - CSA



Capacitive proximity sensors, TRIPLESIELD™

Types	M12 Teach-in TRIPLESIELD™		M18 Teach-in TRIPLESIELD™	
Connections	2 m cable	M12 connector	2 m cable	M12 connector
Flush mountable				
Dimensions (mm)	M12 x 82.4	M12 x 84.7	M18 x 89.55	M18 x 89.2
Thread (mm)	M12 x 1 x 50	M12 x 1 x 50	M18 x 1 x 50	M18 x 1 x 50
Operating frequency	15 Hz	15 Hz	15 Hz	15 Hz
Sensing distance (Sn)	0.5 - 8 mm (Teach-in)	0.5 - 8 mm (Teach-in)	0.2 - 12 mm (Teach-in)	0.2 - 12 mm (Teach-in)
References				
NPN/PNP, NO/NC	CA12CLC08BPRT	CA12CLC08BPM1RT	CA18CLC12BP	CA18CLC12BPM1
Characteristics flush and non-flush mountable				
Rated operating voltage	10 - 40 VDC	10 - 40 VDC	10 - 40 VDC	10 - 40 VDC
Voltage drop	< 2.5 VDC	< 2.5 VDC	< 2.5 VDC	< 2.5 VDC
Degree of protection	IP68	IP68	IP68	IP68
Protection short-circuit (S) Reverse polarity (P) Transients (T)	SPT	SPT	SPT	SPT
Output current	< 250 mA	< 250 mA	< 250 mA	< 250 mA
Housing material	Thermoplastic polyester	Thermoplastic polyester	Thermoplastic polyester	Thermoplastic polyester
Operating temperature	-25°C to +85°C	-25°C to +85°C	-25°C to +85°C	-25°C to +85°C
Special features	Teach-in, humidity compensation NPN/PNP auto detection, remote setup, alarm output. On request: dirt and moisture compensation	Teach-in, humidity compensation NPN/PNP auto detection, remote setup, alarm output. On request: dirt and moisture compensation	Teach-in, humidity compensation NPN/PNP auto detection, remote setup, alarm output. On request: dirt and moisture compensation	Teach-in, humidity compensation NPN/PNP auto detection, remote setup, alarm output. On request: dirt and moisture compensation
Approvals/Marks	CE - UL - CSA	CE - UL - CSA	CE - UL - CSA	CE - UL - CSA

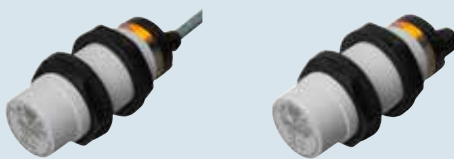



Capacitive proximity sensors, TRIPLESIELD™

Types	M30 Teach-in TRIPLESIELD™		M30 AC/DC TRIPLESIELD™	
Connections	2 m cable	M12 connector	2 m cable	M12 connector
Flush mountable				
Dimensions (mm)	M30 x 99.2	M30 x 90.45	M30 x 63.6	M30 x 75.6
Thread (mm)	M30 x 1.5 x 50	M30 x 1.5 x 50	M30 x 1.5 x 50	M30 x 1.5 x 50
Operating frequency	15 Hz	15 Hz	10 Hz	10 Hz
Sensing distance (Sn)	0.5 - 30 mm (adjustable)	0.5 - 30 mm (adjustable)	2 - 16 mm (adjustable)	2 - 16 mm (adjustable)
References				
NPN/PNP, NO/NC	CA30CLC30BP	CA30CLC30BPM1		
Power MOFSET			CA30CLF16CP	CA30CLF16CPM6
Non-flush mountable				
Dimensions (mm)			M30 x 71.6	M30 x 83.6
Thread (mm)			M30 x 1.5 x 50	M30 x 1.5 x 50
Operating frequency			10 Hz	10 Hz
Sensing distance (Sn)			2 - 25 mm (adjustable)	2 - 25 mm (adjustable)
References				
Power MOFSET			CA30CLN25CP	CA30CLN25CPM6
Characteristics flush and non-flush mountable				
Rated operating voltage	10 - 40 VDC	10 - 40 VDC	20 - 250 VAC/DC	20 - 250 VAC/DC
Voltage drop	< 2.5 VDC	< 2.5 VDC	< 5.5 VAC/DC	< 5.5 VAC/DC
Degree of protection	IP68	IP68	IP67	IP67
Protection short-circuit (S)			PT	PT
Reverse polarity (P)	SPT	SPT		
Transients (T)				
Output current	< 250 mA	< 250 mA	< 250 mA DC < 350 mA AC	< 250 mA DC < 350 mA AC
Housing material	Thermoplastic polyester	Thermoplastic polyester	Thermoplastic polyester	Thermoplastic polyester
Operating temperature	-20°C to +85°C	-20°C to +85°C	-25°C to +80°C	-25°C to +80°C
LED colour	Yellow	Yellow	Yellow	Yellow
Special features	Teach-in, humidity compensation NPN/PNP auto detection, remote setup, alarm output. On request: dirt and moisture compensation	Teach-in, humidity compensation NPN/PNP auto detection, remote setup, alarm output. On request: dirt and moisture compensation		
Approvals/Marks	CE - UL - CSA	CE - UL - CSA	CE - UL - CSA	CE - UL - CSA



Capacitive proximity sensors

Types	M18 TRIPLESIELD™, chemical resistant		High Temperature
Connections	2 m cable	2 m cable	2 m cable
Flush mountable			
Dimensions (mm)	M18 x 71.5	M18 x 71.5	
Thread (mm)	M18 x 1 x 46.5	M18 x 1 x 46.5	
Operating frequency	30 Hz	30 Hz	
Sensing distance (Sn)	3 - 8 mm (adjustable)	3 - 8 mm (adjustable)	
References			
NPN-NO/NC	CA18HLF08NA	CA18GLF08NA	
PNP-NO/NC	CA18HLF08PA	CA18GLF08PA	
Non-flush mountable			
Dimensions (mm)	M18 x 71.5	M30 x 57 + 55 x 15 x 35	
Thread (mm)	M18 x 1 x 46.5	M30 x 1.5 x 30	
Operating frequency	30 Hz	5 Hz	
Sensing distance (Sn)	3 - 12 mm (adjustable)	4 - 15 mm adjustable (Def. 10 mm)	
References			
NPN-NO/NC	CA18HLN12NA	ECH301ONPAT-1	
PNP-NO/NC	CA18HLN12PA	ECH301OPPAT-1	
Characteristics flush and non-flush mountable			
Rated operating voltage	10 - 40 VDC	10 - 40 VDC	10 - 40 VDC
Voltage drop	≤ 2.5 VDC	≤ 2.5 VDC	≤ 2.0 VDC
Degree of protection	IP67	IP67	IP67, Nema 1, 3, 4, 6, 13
Protection short-circuit (S) Reverse polarity (P) Transients (T)	SPT	SPT	SPT
Output current	< 200 mA	< 200 mA	< 200 mA
Housing material	Polypropylene	PVC	Sensor PTFE. Amplifier PBT
Operating temperature	-25°C to +80°C	-25°C to +80°C	-25°C to +70°C
LED colour	Yellow	Yellow	Yellow
Approvals/Marks	CE	CE	CE



Capacitive proximity sensors, TRIPLESIELD™

Types	VC5510	VC5510 Time delay	CD50	
Connections	1.5 m cable	1.5 m cable	2 m cable	2 m cable
Flush mountable				
Dimensions (mm)	55 x 35 x 15	55 x 35 x 15	50 x 30 x 7	50 x 30 x 7
Operating frequency	> 15 Hz	> 0.1 Hz	10 Hz	10 Hz
Sensing distance (Sn)	10 mm	10 mm	6 mm	5 mm
References				
NPN - NO	VC5510NNOP	VC5510NNOPT	CD50CNF06NO	CD50CNF05NO
NPN - NC	VC5510NNCP	VC5510NNCPT		
PNP - NO	VC5510PNOP	VC5510PNOPT		
PNP - NC	VC5510PNCP	VC5510PNCPT		
Sensing distance (Sn)			7 mm	
PNP - NO			CD50CNF07PO	
NPN - NC			CD50CNF07NC	
Sensing distance (Sn)			10 mm	
PNP - NO			CD50CNF10PO	
NPN - NC			CD50CNF10NC	
Characteristics flush and non-flush mountable				
Rated operating voltage	5 - 30 VDC	5 - 30 VDC	10 - 30 VDC	5 VDC
Voltage drop	≤ 1.5 VDC	≤ 1.5 VDC	≤ 1.5 V	≤ 1.5 V
Degree of protection	IP65	IP65	IP67	IP67
Output current	≤ 100 mA	≤ 100 mA	≤ 50 mA	≤ 50 mA
Housing material	PC/ABS	PC/ABS	Noryl, grey	Noryl, grey
Operating temperature	0°C to +50°C	0°C to +50°C	0°C to +60°C	0°C to +60°C
LED colour	Red	Red		
Approvals/Marks	CE - UL	CE - UL	CE	CE

Capacitive proximity sensors, TRIPLESIELD™

Types	CD46 Teach-in TRIPLESIELD™	EC 5525 TRIPLESIELD™	
Connections	2 m cable	2 m cable	M12 connector
Flush or Non-flush mountable			
	Dimensions short body (mm)	46 x 28 x 5.5	55 x 35 x 15
Operating frequency	10 Hz	50 Hz	50 Hz
Sensing distance (Sn)	1.0 - 10 mm (Teach-in)	4 - 25 mm	4 - 25 mm
References			
NPN-NO/NC	CD46CNC10NP	EC5525NPAP	EC5525NPAP-1
PNP-NO/NC	CD46CNC10PP	EC5525PPAP	EC5525PPAP-1
Characteristics flush and non-flush mountable			
Rated operating voltage	10 - 30 VDC	10 - 40 VDC	10 - 40 VDC
Voltage drop	≤ 2.5 VDC	≤ 2.5 VDC	≤ 2.5 VDC
Degree of protection	IP68	IP67	IP67
Protection short-circuit (S) Reverse polarity (P) Transients (T)	SPT	SPT	SPT
Output current	≤ 200 mA	≤ 200 mA	≤ 200 mA
Housing material	PBT	Polycarbonate	Polycarbonate
Operating temperature	-25°C to +80°C	-25°C to +80°C	-25°C to +80°C
LED colour	Yellow, Green	Yellow	Yellow
Special features	Teach-in, remote setup, alarm output		
Approvals/Marks	CE - UL - CSA	CE - UL - CSA	CE - UL - CSA

Capacitive proximity sensors, TRIPLESIELD™

Types	M18 Teach-in TRIPLESIELD™		M30 Teach-in TRIPLESIELD™	
Connections	2 m cable	M12 connector	2 m cable	M12 connector
Flush or Non-flush mountable				
Dimensions (mm)	M18 x 89.55	M18 x 89.2	M30 x 99.2	M30 x 99.45
Thread (mm)	M18 x 1 x 50	M18 x 1 x 50	M30 x 1.5 x 50	M30 x 1.5 x 50
Operating frequency	5 Hz	5 Hz	5 Hz	5 Hz
Sensing distance (Sn)	0.5 - 12 mm (Teach-in)	0.5 - 12 mm (Teach-in)	0.5 - 30 mm (Teach-in)	0.5 - 30 mm (Teach-in)
References				
NPN/PNP, NO/NC	CA18CLL12BP	CA18CLL12BPM1	CA30CLL30BP	CA30CLL30BPM1
Characteristics flush and non-flush mountable				
Rated operating voltage	10 - 40 VDC	10 - 40 VDC	10 - 40 VDC	10 - 40 VDC
Voltage drop	≤ 2.5 VDC	≤ 2.5 VDC	≤ 2.5 VDC	≤ 2.5 VDC
Degree of protection	IP68	IP68	IP68	IP68
Output current	≤ 250 mA	≤ 250 mA	≤ 250 mA	≤ 250 mA
Housing material	Thermoplastic polyester	Thermoplastic polyester	Thermoplastic polyester	Thermoplastic polyester
Operating temperature	-20°C to +85°C	-20°C to +85°C	-20°C to +85°C	-20°C to +85°C
Max. temperature on sensing face	120°C (248°F)	120°C (248°F)	120°C (248°F)	120°C (248°F)
LED colour	Yellow	Yellow	Yellow	Yellow
Special features	Single-step Teach-in, humidity compensation NPN/PNP auto detection, remote setup, alarm output. On request: dirt and moisture compensation	Single-step Teach-in, humidity compensation NPN/PNP auto detection, remote setup, alarm output. On request: dirt and moisture compensation	Single-step Teach-in, humidity compensation NPN/PNP auto detection, remote setup, alarm output. On request: dirt and moisture compensation	Single-step Teach-in, humidity compensation NPN/PNP auto detection, remote setup, alarm output. On request: dirt and moisture compensation
Approvals/Marks	CE - UL - CSA	CE - UL - CSA	CE - UL - CSA	CE - UL - CSA

Capacitive level sensors

Types

Capacitive liquid level sensors

Connections





2 m cable

M8, 4-pin pig-tail





Dimensions (mm)	34 x 16 x 8	34 x 16 x 8
Operating frequency	10 Hz	10 Hz
Tank wall thickness (out-of-the-box)	0.5 to 6 mm plastic, 0.5 to 4 mm glass	0.5 to 6 mm plastic, 0.5 to 4 mm glass
Teach-in	Empty or full tank	Empty or full tank
References		
NPN - NC	CD34CNFLNCP2	CD34CNFLFNCT5
NPN - NO	CD34CNFLFNOP2	CD34CNFLFNOT4
PNP - NC	CD34CNFLFPCP2	CD34CNFLFPCT5
PNP - NO	CD34CNFLFPOP2	CD34CNFLFPOT5
Specifications		
Rated operating voltage	10 - 30 VDC	10 - 30 VDC
Voltage drop	≤ 1.5 VDC	≤ 1.5 VDC
Degree of protection	IP65, IP66, IP67, IP68 (1.3 m @ 24h), IP69K NEMA 1, 2, 4, 4X, 5, 12	IP65, IP66, IP67, IP68 (1.3 m @ 24h), IP69K NEMA 1, 2, 4, 4X, 5, 12
Protection short-circuit (S) Reverse polarity (P) Transients (T)	SPT	SPT
Output current	< 100 mA	< 100 mA
Housing material	PBT	PBT
Operating temperature	-25°C to +80°C	-25°C to +80°C
LED colour	Yellow and Green	Yellow and Green
Special features	Designed to eliminate tank walls and build-up of foam or film on tank walls. Detection liquids: water-based liquids such as water, milk, syrup, milkshakes, lubricants, acids, alkaline, body fluids and highly conductive liquids up to 50 ms	Designed to eliminate tank walls and build-up of foam or film on tank walls. Detection liquids: water-based liquids such as water, milk, syrup, milkshakes, lubricants, acids, alkaline, body fluids and highly conductive liquids up to 50 ms
Approvals/Marks	CE - cULus - ECOLAB	CE - cULus - ECOLAB
Accessories	Mounting Bracket ACD34-MB01	Mounting Bracket ACD34-MB01

Capacitive level sensors

Types	Capacitive level sensors for solid, fluid and granulated substances			
Connections	2 m cable	2 m cable	2 m cable	2 m cable
				
Dimensions (mm)	Ø32 x 101	Ø32 x 101	Ø32 x 101	M30 x 101
Thread	Smooth	Smooth	Smooth	M30 (with 2 nuts)
Operating frequency	1 Hz	1 Hz	1 Hz	1 Hz
Sensing distance (Sn)	4 - 12 mm (adjustable)	4 - 12 mm (adjustable)	4 - 12 mm (adjustable)	4 - 12 mm (adjustable)
References with ON delay				
Time delay	1 s - 10 m			1 s - 10 m
120 VAC	VC11RT12010M			
230 VAC	VC11RT23010M			
24 VAC/DC	VC11RT92410M			
24-230 VAC/DC	VC11RTM2410M			CA30CLN12MU10M
References with OFF delay				
Time delay	1 s - 10 m			1 s - 10 m
120 VAC	VC12RT12010M			
230 VAC	VC12RT23010M			
24 VAC/DC	VC12RT92410M			
24-230 VAC/DC	VC12RTM2410M			CA30CLN12MV10M
References without delay				
120 VAC	VC12RN120			
230 VAC	VC12RN230			
24 VAC/DC	VC12RN924			
24-230 VAC/DC	VC12RNM24			CA30CLN12MT
Specifications				
Consumption	≤ 1.5 W	≤ 1.5 W	≤ 1.5 W	≤ 2.5 W
Consumption M24 versions	≤ 2.5 W	≤ 2.5 W	≤ 2.5 W	
Hysteresis	1.5 mm at 7 mm sensing distance	1.5 mm at 7 mm sensing distance	1.5 mm at 7 mm sensing distance	3 - 20%
Output	Relay SPDT 2 A / 240 VAC	Relay SPDT 2 A / 240 VAC	Relay SPDT 2 A / 240 VAC	Relay SPDT 2 A / 240 VAC
Degree of protection	IP67	IP67	IP67	IP67
Housing material	Thermoplastic polyester	Thermoplastic polyester	Thermoplastic polyester	PBTP, grey
Operating temperature	-20°C to +70°C	-20°C to +70°C	-20°C to +70°C	-20°C to +70°C
LED colour	Red	Red	Red	Yellow
Approvals/Marks	CE	CE - CSA	CE	CE, CSA
UL508	cULus (M24 versions)	cULus (M24 versions)	cULus (M24 versions)	cULus
NEMA				1, 2, 4, 4X, 5, 6, 6P, 12

Capacitive level sensors

	Ø18 Sensors for solid, fluid and granulated substances		Ø32 Sensors
Types	2-wire, AC	3-wire, DC	2-wire, AC
Connections	2 m cable	2 m cable	2 m cable
			
Dimensions (mm)	Ø18 x 86	Ø18 x 86	Ø32 x 101
Thread	Smooth	Smooth	Smooth
Operating frequency	10 Hz	30 Hz	10 Hz
Sensing distance (Sn)	3 - 12 mm (adjustable)	3 - 12 mm (adjustable)	2 - 20 mm (adjustable)
References			
Thyristor (SCR) NO	CB18CLN12TOFT		
Thyristor (SCR) NO ATEX	CB18CLN12TOFTAX		
Thyristor (SCR) NC	CB18CLN12TCFT		
Thyristor (SCR) NC ATEX	CB18CLN12TCFTAX		
NPN - NO/NC		CB18CLN12NA	
NPN - NO/NC ATEX		CB18CLN12NAAX	
PNP - NO/NC		CB18CLN12PA	
PNP - NO/NC ATEX		CB18CLN12PAAX	
ON-delay			No
Thyristor (SCR) NO			CB32CLN20TO
Thyristor (SCR) NO ATEX			CB32CLN20TOAX
Thyristor (SCR) NC			CB32CLN20TC
Thyristor (SCR) NC ATEX			CB32CLN20TCAX
ON-delay			Yes
Thyristor (SCR) NO			CB32CLN20TOFT
Thyristor (SCR) NO ATEX			CB32CLN20TOFTAX
Thyristor (SCR) NC			CB32CLN20TCFT
Thyristor (SCR) NC ATEX			CB32CLN20TCFTAX
Specifications			
Rated operating voltage	20 - 250 VAC	10 - 40 VDC	20 - 250 VAC
Voltage drop	≤ 10 VAC	≤ 10 VAC	≤ 10 VAC
Time delay	30 s ON-delay		30 s ON-delay
Degree of protection	IP67	IP67	IP67
Protection short-circuit (S)			
Reverse polarity (P)	T	SPT	T
Transients (T)			
Output current	≤ 500 mA	≤ 200 mA	≤ 500 mA
Housing material	Thermoplastic polyester	Thermoplastic polyester	Thermoplastic polyester
Operating temperature	-25°C to +80°C	-25°C to +80°C	-20°C to +70°C
LED colour	Yellow	Yellow	Yellow
Approvals/Marks	CE - UL - CSA - ATEX	CE - UL - CSA - ATEX	CE - UL - CSA - ATEX

Capacitive level sensors

Types Ø32 Level sensors TRIPLESIELD™ - ATEX

Connections	With ON delay	With OFF delay	Without time delay
-------------	---------------	----------------	--------------------



Dimensions (mm)	Ø32 x 101	Ø32 x 101	Ø32 x 101
Thread	Smooth	Smooth	Smooth
Operating frequency	5 Hz	5 Hz	5 Hz
Sensing distance (Sn)	4 - 20 mm (adjustable)	4 - 20 mm (adjustable)	4 - 20 mm (adjustable)





References

Cable length	2 m	2 m	2 m
120 VAC	CB32CLN20SUAX	CB32CLN20SVAX	CB32CLN20STAX
230 VAC	CB32CLN20RUAX	CB32CLN20RVAX	CB32CLN20RTAX
24 VAC/DC	CB32CLN20QUAX	CB32CLN20QVAX	CB32CLN20QTAX
Cable length	5 m	5 m	5 m
120 VAC	CB32CLN20SUAX5M	CB32CLN20SVAX5M	CB32CLN20STAX5M
230 VAC	CB32CLN20RUAX5M	CB32CLN20RVAX5M	CB32CLN20RTAX5M
24 VAC/DC	CB32CLN20QUAX5M	CB32CLN20QVAX5M	CB32CLN20QTAX5M
Cable length	10 m	10 m	10 m
120 VAC	CB32CLN20SUAX10M	CB32CLN20SVAX10M	CB32CLN20STAX10M
230 VAC	CB32CLN20RUAX10M	CB32CLN20RVAX10M	CB32CLN20RTAX10M
24 VAC/DC	CB32CLN20QUAX10M	CB32CLN20QVAX10M	CB32CLN20QTAX10M



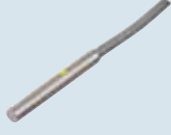

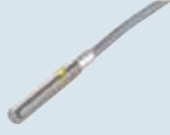



Specifications

Consumption	< 1.5 W	< 1.5 W	< 1.5 W
Hysteresis	3 to 20% of sensing distance	3 to 20% of sensing distance	3 to 20% of sensing distance
Output	Relay SPDT, 2 A / 240 VAC	Relay SPDT, 2 A / 240 VAC	Relay SPDT, 2 A / 240 VAC
Time delay	1 s - 10 m	1 s - 10 m	
Degree of protection	IP67	IP67	IP67
Housing material	PBT	PBT	PBT
Operating temperature	-20°C to +70°C	-20°C to +70°C	-20°C to +70°C
LED colour	Yellow	Yellow	Yellow
Approvals/Marks	CE - ATEX	CE - ATEX	CE - ATEX





Inductive proximity sensors, 3-wire, DC, IO-Link





Types	Ø4 IO-Link - Short body		M5 IO-Link - Short body	
Connections	2 m cable	M8 connector	2 m cable	M8 connector
Flush mountable				
Dimensions (mm)	Ø4 x 28.2	Ø4 x 38.2	M5 x 28.2	M5 x 38.2
Thread (mm)	-	-	M5 x 0.5 x 23	M5 x 0.5 x 23
Operating frequency	4.5 kHz (extended range) 6 kHz (standard range)	4.5 kHz (extended range) 6 kHz (standard range)	4.5 kHz (extended range) 6 kHz (standard range)	4.5 kHz (extended range) 6 kHz (standard range)
Sensing distance (Sn)	0.8 or 1.3 mm (adjustable)	0.8 or 1.3 mm (adjustable)	0.8 or 1.3 mm (adjustable)	0.8 or 1.3 mm (adjustable)
References	IBS04SF15A2IO	IBS04SF15M5IO	ICS05S23F15A2IO	ICS05S23F15M5IO
Characteristics				
Output configuration	NPN, PNP or push-pull NO or NC	NPN, PNP or push-pull NO or NC	NPN, PNP or push-pull NO or NC	NPN, PNP or push-pull NO or NC
Adjustable hysteresis	Standard or increased value	Standard or increased value	Standard or increased value	Standard or increased value
Timer functions	ON delay, OFF delay, ON + OFF delay and one shot	ON delay, OFF delay, ON + OFF delay and one shot	ON delay, OFF delay, ON + OFF delay and one shot	ON delay, OFF delay, ON + OFF delay and one shot
Switchpoint mode	Single point, two point or window	Single point, two point or window	Single point, two point or window	Single point, two point or window
Advanced functions	RPM counter, rotational speed monitoring	RPM counter, rotational speed monitoring	RPM counter, rotational speed monitoring	RPM counter, rotational speed monitoring
Diagnostic functions	Underrun and overrun temperature events, frequency monitoring	Underrun and overrun temperature events, frequency monitoring	Underrun and overrun temperature events, frequency monitoring	Underrun and overrun temperature events, frequency monitoring
Rated operating voltage	10 - 30 VDC	10 - 30 VDC	10 - 30 VDC	10 - 30 VDC
Voltage drop	max. 1.2 VDC (@ 100 mA)	max. 1.2 VDC (@ 100 mA)	max. 1.2 VDC (@ 100 mA)	max. 1.2 VDC (@ 100 mA)
No load supply current (I _o)	≤ 20 mA	≤ 20 mA	≤ 20 mA	≤ 20 mA
Degree of protection	IP67	IP67	IP67	IP67
Protection short-circuit (S) Reverse polarity (P) Transients (T)	SPT	SPT	SPT	SPT
Output current	≤ 100 mA	≤ 100 mA	≤ 100 mA	≤ 100 mA
Housing material	Stainless steel	Stainless steel	Stainless steel	Stainless steel
Operating temperature	-25°C to +70°C	-25°C to +70°C	-25°C to +70°C	-25°C to +70°C
LED colour	Yellow	Yellow	Yellow	Yellow
Communication interface	IO-Link	IO-Link	IO-Link	IO-Link
Transmission type	COM2 (38,4 kBaud)	COM2 (38,4 kBaud)	COM2 (38,4 kBaud)	COM2 (38,4 kBaud)
IO-Link revision	V 1.1	V 1.1	V 1.1	V 1.1
SDCI standard	IEC 61131-9	IEC 61131-9	IEC 61131-9	IEC 61131-9
Profiles	Smart Sensor: Process Data Variable; Device Identification	Smart Sensor: Process Data Variable; Device Identification	Smart Sensor: Process Data Variable; Device Identification	Smart Sensor: Process Data Variable; Device Identification
SIO mode	Yes	Yes	Yes	Yes
Required master port type	A	A	A	A
Min. process cycle time [ms]	10.4 ms	10.4 ms	10.4 ms	10.4 ms
Approvals/Marks	CE - UL - CSA	CE - UL - CSA	CE - UL - CSA	CE - UL - CSA

Inductive proximity sensors, 3-wire, DC, IO-Link

Types	M8 IO-Link - Short body		M8 IO-Link - Long body	
Connections	2 m cable	M8 connector	2 m cable	M8 connector
Flush mountable				
Dimensions (mm)	M8 x 31	M8 x 40	M8 x 46	M8 x 55
Thread (mm)	M8 x 1 x 30	M8 x 1 x 29	M8 x 1 x 45	M8 x 1 x 44
Operating frequency	2 kHz	2 kHz	2 kHz	2 kHz
Sensing distance (Sn)	1 or 2 mm (adjustable)	1 or 2 mm (adjustable)	1 or 2 mm (adjustable)	1 or 2 mm (adjustable)
References	ICS08S30F20A2IO	ICS08S30F20M5IO	ICS08L45F20A2IO	ICS08L45F20M5IO
Non-flush mountable				
Dimensions (mm)	M8 x 34	M8 x 43	M8 x 49	M8 x 58
Thread (mm)	M8 x 1 x 30	M8 x 1 x 29	M8 x 1 x 45	M8 x 1 x 44
Operating frequency	2 kHz	2 kHz	2 kHz	2 kHz
Sensing distance (Sn)	2 or 4 mm (adjustable)	2 or 4 mm (adjustable)	2 or 4 mm (adjustable)	2 or 4 mm (adjustable)
References	ICS08S30N40A2IO	ICS08S30N40M5IO	ICS08L45N40A2IO	ICS08L45N40M5IO
Characteristics flush and non-flush mountable				
Output configuration	NPN, PNP or push-pull NO or NC	NPN, PNP or push-pull NO or NC	NPN, PNP or push-pull NO or NC	NPN, PNP or push-pull NO or NC
Adjustable hysteresis	Standard or increased value	Standard or increased value	Standard or increased value	Standard or increased value
Timer functions	ON delay, OFF delay, ON + OFF delay and one shot	ON delay, OFF delay, ON + OFF delay and one shot	ON delay, OFF delay, ON + OFF delay and one shot	ON delay, OFF delay, ON + OFF delay and one shot
Switchpoint mode	Single point, two point or window	Single point, two point or window	Single point, two point or window	Single point, two point or window
Advanced functions	RPM counter, rotational speed monitoring	RPM counter, rotational speed monitoring	RPM counter, rotational speed monitoring	RPM counter, rotational speed monitoring
Diagnostic functions	Underrun and overrun temperature events, frequency monitoring	Underrun and overrun temperature events, frequency monitoring	Underrun and overrun temperature events, frequency monitoring	Underrun and overrun temperature events, frequency monitoring
Rated operating voltage	10 - 30 VDC	10 - 30 VDC	10 - 30 VDC	10 - 30 VDC
Voltage drop	max. 1.2 VDC (@ 100 mA)	max. 1.2 VDC (@ 100 mA)	max. 1.2 VDC (@ 100 mA)	max. 1.2 VDC (@ 100 mA)
No load supply current (I _o)	≤ 20 mA	≤ 20 mA	≤ 20 mA	≤ 20 mA
Degree of protection	IP67	IP67	IP67	IP67
Protection short-circuit (S)				
Reverse polarity (P)	SPT	SPT	SPT	SPT
Transients (T)				
Output current	≤ 100 mA	≤ 100 mA	≤ 100 mA	≤ 100 mA
Housing material	Stainless steel	Stainless steel	Stainless steel	Stainless steel
Operating temperature	-25°C to +80°C	-25°C to +80°C	-25°C to +80°C	-25°C to +80°C
LED colour	Yellow	Yellow	Yellow	Yellow
Communication interface	IO-Link	IO-Link	IO-Link	IO-Link
Transmission type	COM2 (38,4 kBaud)	COM2 (38,4 kBaud)	COM2 (38,4 kBaud)	COM2 (38,4 kBaud)
IO-Link revision	V 1.1	V 1.1	V 1.1	V 1.1
SDCI standard	IEC 61131-9	IEC 61131-9	IEC 61131-9	IEC 61131-9
Profiles	Smart Sensor: Process Data Variable; Device Identification	Smart Sensor: Process Data Variable; Device Identification	Smart Sensor: Process Data Variable; Device Identification	Smart Sensor: Process Data Variable; Device Identification
SIO mode	Yes	Yes	Yes	Yes
Required master port type	A	A	A	A
Min. process cycle time [ms]	10.4 ms	10.4 ms	10.4 ms	10.4 ms
Approvals/Marks	CE - UL - CSA	CE - UL - CSA	CE - UL - CSA	CE - UL - CSA

Inductive proximity sensors, 3-wire, DC, IO-Link





Types	M12 IO-Link - Short body		M12 IO-Link - Long body	
Connections	2 m cable	M12 connector	2 m cable	M12 connector
Flush mountable				
Dimensions (mm)	M12 x 32	M12 x 50.2	M12 x 52	M12 x 70.2
Thread (mm)	M12 x 1 x 30	M12 x 1 x 30	M12 x 1 x 50	M12 x 1 x 50
Operating frequency	2 kHz	2 kHz	2 kHz	2 kHz
Sensing distance (Sn)	33%, 50%, 75% or 100% of 4 mm	33%, 50%, 75% or 100% of 4 mm	33%, 50%, 75% or 100% of 4 mm	33%, 50%, 75% or 100% of 4 mm
References	ICB12S30F04A2IO	ICB12S30F04M1IO	ICB12L50F04A2IO	ICB12L50F04M1IO





Non-flush mountable				
Dimensions (mm)	M12 x 36	M12 x 54.2	M12 x 56	M12 x 74.2
Thread (mm)	M12 x 1 x 30	M12 x 1 x 30	M12 x 1 x 50	M12 x 1 x 50
Operating frequency	2 kHz	2 kHz	2 kHz	2 kHz
Sensing distance (Sn)	33%, 50%, 75% or 100% of 8 mm	33%, 50%, 75% or 100% of 8 mm	33%, 50%, 75% or 100% of 8 mm	33%, 50%, 75% or 100% of 8 mm
References	ICB12S30N08A2IO	ICB12S30N08M1IO	ICB12L50N08A2IO	ICB12L50N08M1IO

Characteristics flush and non-flush mountable

Output configuration	NPN, PNP or push-pull NO or NC	NPN, PNP or push-pull NO or NC	NPN, PNP or push-pull NO or NC	NPN, PNP or push-pull NO or NC
Adjustable hysteresis	Standard or increased value	Standard or increased value	Standard or increased value	Standard or increased value
Timer functions	ON delay, OFF delay, ON + OFF delay and one shot	ON delay, OFF delay, ON + OFF delay and one shot	ON delay, OFF delay, ON + OFF delay and one shot	ON delay, OFF delay, ON + OFF delay and one shot
Switchpoint mode	Single point, two point or window	Single point, two point or window	Single point, two point or window	Single point, two point or window
Advanced functions	RPM counter, rotational speed monitoring	RPM counter, rotational speed monitoring	RPM counter, rotational speed monitoring	RPM counter, rotational speed monitoring
Diagnostic functions	Underrun and overrun temperature events, frequency monitoring	Underrun and overrun temperature events, frequency monitoring	Underrun and overrun temperature events, frequency monitoring	Underrun and overrun temperature events, frequency monitoring
Rated operating voltage	10 - 36 VDC	10 - 36 VDC	10 - 36 VDC	10 - 36 VDC
Voltage drop	max. 2.5 VDC @ 200 mA	max. 2.5 VDC @ 200 mA	max. 2.5 VDC @ 200 mA	max. 2.5 VDC @ 200 mA
No load supply current (I _o)	≤ 20 mA	≤ 20 mA	≤ 20 mA	≤ 20 mA
Degree of protection	IP67	IP67	IP67	IP67
Protection short-circuit (S)	SPT	SPT	SPT	SPT
Reverse polarity (P)				
Transients (T)				
Output current	≤ 200 mA	≤ 200 mA	≤ 200 mA	≤ 200 mA
Housing material	Nickel-plated brass	Nickel-plated brass	Nickel-plated brass	Nickel-plated brass
Operating temperature	-25°C to +70°C	-40°C to +70°C	-25°C to +70°C	-40°C to +70°C
LED colour	Yellow and Green	Yellow and Green	Yellow and Green	Yellow and Green
Communication interface	IO-Link	IO-Link	IO-Link	IO-Link
Transmission type	COM2 (38,4 kBaud)	COM2 (38,4 kBaud)	COM2 (38,4 kBaud)	COM2 (38,4 kBaud)
IO-Link revision	V 1.1	V 1.1	V 1.1	V 1.1
SDCI standard	IEC 61131-9	IEC 61131-9	IEC 61131-9	IEC 61131-9
Profiles	Smart Sensor: Process Data Variable; Device Identification	Smart Sensor: Process Data Variable; Device Identification	Smart Sensor: Process Data Variable; Device Identification	Smart Sensor: Process Data Variable; Device Identification
SIO mode	Yes	Yes	Yes	Yes
Required master port type	A	A	A	A
Min. process cycle time [ms]	10.4 ms	10.4 ms	10.4 ms	10.4 ms
Approvals/Marks	CE - cULus	CE - cULus	CE - cULus	CE - cULus

Inductive proximity sensors, 3-wire, DC, IO-Link





Types	M18 IO-Link - Short body		M18 IO-Link - Long body	
Connections	2 m cable	M12 connector	2 m cable	M12 connector
Flush mountable				
Dimensions (mm)	M18 x 32	M18 x 54	M18 x 52	M18 x 74
Thread (mm)	M18 x 1 x 30	M18 x 1 x 30	M18 x 1 x 50	M18 x 1 x 50
Operating frequency	1.5 kHz	1.5 kHz	1.5 kHz	1.5 kHz
Sensing distance (Sn)	33%, 50%, 75% or 100% of 8 mm	33%, 50%, 75% or 100% of 8 mm	33%, 50%, 75% or 100% of 8 mm	33%, 50%, 75% or 100% of 8 mm
References	ICB18S30F08A2IO	ICB18S30F08M1IO	ICB18L50F08A2IO	ICB18L50F08M1IO





Non-flush mountable				
Dimensions (mm)	M18 x 42	M18 x 64	M18 x 62	M18 x 84
Thread (mm)	M18 x 1 x 30	M18 x 1 x 30	M18 x 1 x 50	M18 x 1 x 50
Operating frequency	1.5 kHz	1.5 kHz	1.5 kHz	1.5 kHz
Sensing distance (Sn)	33%, 50%, 75% or 100% of 14 mm	33%, 50%, 75% or 100% of 14 mm	33%, 50%, 75% or 100% of 14 mm	33%, 50%, 75% or 100% of 14 mm
References	ICB18S30N14A2IO	ICB18S30N14M1IO	ICB18L50N14A2IO	ICB18L50N14M1IO

Characteristics flush and non-flush mountable

Output configuration	NPN, PNP or push-pull NO or NC	NPN, PNP or push-pull NO or NC	NPN, PNP or push-pull NO or NC	NPN, PNP or push-pull NO or NC
Adjustable hysteresis	Standard or increased value	Standard or increased value	Standard or increased value	Standard or increased value
Timer functions	ON delay, OFF delay, ON + OFF delay and one shot	ON delay, OFF delay, ON + OFF delay and one shot	ON delay, OFF delay, ON + OFF delay and one shot	ON delay, OFF delay, ON + OFF delay and one shot
Switchpoint mode	Single point, two point or window	Single point, two point or window	Single point, two point or window	Single point, two point or window
Advanced functions	RPM counter, rotational speed monitoring	RPM counter, rotational speed monitoring	RPM counter, rotational speed monitoring	RPM counter, rotational speed monitoring
Diagnostic functions	Underrun and overrun temperature events, frequency monitoring	Underrun and overrun temperature events, frequency monitoring	Underrun and overrun temperature events, frequency monitoring	Underrun and overrun temperature events, frequency monitoring
Rated operating voltage	10 - 36 VDC	10 - 36 VDC	10 - 36 VDC	10 - 36 VDC
Voltage drop	max. 2.5 VDC @ 200 mA	max. 2.5 VDC @ 200 mA	max. 2.5 VDC @ 200 mA	max. 2.5 VDC @ 200 mA
No load supply current (I _o)	≤ 20 mA	≤ 20 mA	≤ 20 mA	≤ 20 mA
Degree of protection	IP67	IP67	IP67	IP67
Protection short-circuit (S)				
Reverse polarity (P)	SPT	SPT	SPT	SPT
Transients (T)				
Output current	≤ 200 mA	≤ 200 mA	≤ 200 mA	≤ 200 mA
Housing material	Nickel-plated brass	Nickel-plated brass	Nickel-plated brass	Nickel-plated brass
Operating temperature	-25°C to +70°C	-40°C to +70°C	-25°C to +70°C	-40°C to +70°C
LED colour	Yellow and Green	Yellow and Green	Yellow and Green	Yellow and Green
Communication interface	IO-Link	IO-Link	IO-Link	IO-Link
Transmission type	COM2 (38,4 kBaud)	COM2 (38,4 kBaud)	COM2 (38,4 kBaud)	COM2 (38,4 kBaud)
IO-Link revision	V 1.1	V 1.1	V 1.1	V 1.1
SDCI standard	IEC 61131-9	IEC 61131-9	IEC 61131-9	IEC 61131-9
Profiles	Smart Sensor: Process Data Variable; Device Identification	Smart Sensor: Process Data Variable; Device Identification	Smart Sensor: Process Data Variable; Device Identification	Smart Sensor: Process Data Variable; Device Identification
SIO mode	Yes	Yes	Yes	Yes
Required master port type	A	A	A	A
Min. process cycle time [ms]	10.4 ms	10.4 ms	10.4 ms	10.4 ms
Approvals/Marks	CE - cULus	CE - cULus	CE - cULus	CE - cULus

Inductive proximity sensors, 3-wire, DC, IO-Link





Types	M30 IO-Link - Short body		M30 IO-Link - Long body	
Connections	2 m cable	M12 connector	2 m cable	M12 connector
Flush mountable				
Dimensions (mm)	M30 x 32	M30 x 55	M30 x 52	M30 x 75
Thread (mm)	M30 x 1.5 x 30	M30 x 1.5 x 30	M30 x 1.5 x 50	M30 x 1.5 x 50
Operating frequency	1 kHz	1 kHz	1 kHz	1 kHz
Sensing distance (Sn)	33%, 50%, 75% or 100% of 15 mm	33%, 50%, 75% or 100% of 15 mm	33%, 50%, 75% or 100% of 15 mm	33%, 50%, 75% or 100% of 15 mm
References	ICB30S30F15A2IO	ICB30S30F15M1IO	ICB30L50F15A2IO	ICB30L50F15M1IO





Non-flush mountable				
Dimensions (mm)	M30 x 44	M30 x 67	M30 x 64	M30 x 87
Thread (mm)	M30 x 1.5 x 30	M30 x 1.5 x 30	M30 x 1.5 x 50	M30 x 1.5 x 50
Operating frequency	1 kHz	1 kHz	1 kHz	1 kHz
Sensing distance (Sn)	33%, 50%, 75% or 100% of 22 mm	33%, 50%, 75% or 100% of 22 mm	33%, 50%, 75% or 100% of 22 mm	33%, 50%, 75% or 100% of 22 mm
References	ICB30S30N22A2IO	ICB30S30N22M1IO	ICB30L50N22A2IO	ICB30L50N22M1IO

Characteristics flush and non-flush mountable

Output configuration	NPN, PNP or push-pull NO or NC	NPN, PNP or push-pull NO or NC	NPN, PNP or push-pull NO or NC	NPN, PNP or push-pull NO or NC
Adjustable hysteresis	Standard or increased value	Standard or increased value	Standard or increased value	Standard or increased value
Timer functions	ON delay, OFF delay, ON + OFF delay and one shot	ON delay, OFF delay, ON + OFF delay and one shot	ON delay, OFF delay, ON + OFF delay and one shot	ON delay, OFF delay, ON + OFF delay and one shot
Switchpoint mode	Single point, two point or window	Single point, two point or window	Single point, two point or window	Single point, two point or window
Advanced functions	RPM counter, rotational speed monitoring	RPM counter, rotational speed monitoring	RPM counter, rotational speed monitoring	RPM counter, rotational speed monitoring
Diagnostic functions	Underrun and overrun temperature events, frequency monitoring	Underrun and overrun temperature events, frequency monitoring	Underrun and overrun temperature events, frequency monitoring	Underrun and overrun temperature events, frequency monitoring
Rated operating voltage	10 - 36 VDC	10 - 36 VDC	10 - 36 VDC	10 - 36 VDC
Voltage drop	max. 2.5 VDC @ 200 mA	max. 2.5 VDC @ 200 mA	max. 2.5 VDC @ 200 mA	max. 2.5 VDC @ 200 mA
No load supply current (I _o)	≤ 20 mA	≤ 20 mA	≤ 20 mA	≤ 20 mA
Degree of protection	IP67	IP67	IP67	IP67
Protection short-circuit (S)	SPT	SPT	SPT	SPT
Reverse polarity (P)				
Transients (T)				
Output current	≤ 200 mA	≤ 200 mA	≤ 200 mA	≤ 200 mA
Housing material	Nickel-plated brass	Nickel-plated brass	Nickel-plated brass	Nickel-plated brass
Operating temperature	-25°C to +70°C	-40°C to +70°C	-25°C to +70°C	-40°C to +70°C
LED colour	Yellow and Green	Yellow and Green	Yellow and Green	Yellow and Green
Communication interface	IO-Link	IO-Link	IO-Link	IO-Link
Transmission type	COM2 (38,4 kBaud)	COM2 (38,4 kBaud)	COM2 (38,4 kBaud)	COM2 (38,4 kBaud)
IO-Link revision	V 1.1	V 1.1	V 1.1	V 1.1
SDCI standard	IEC 61131-9	IEC 61131-9	IEC 61131-9	IEC 61131-9
Profiles	Smart Sensor: Process Data Variable; Device Identification	Smart Sensor: Process Data Variable; Device Identification	Smart Sensor: Process Data Variable; Device Identification	Smart Sensor: Process Data Variable; Device Identification
SIO mode	Yes	Yes	Yes	Yes
Required master port type	A	A	A	A
Min. process cycle time [ms]	10.4 ms	10.4 ms	10.4 ms	10.4 ms
Approvals/Marks	CE - cULus	CE - cULus	CE - cULus	CE - cULus

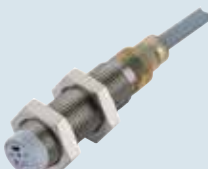
Inductive proximity sensors, 3-wire, DC





Types	M12 Standard - Short body		M12 Standard - Long body	
Connections	2 m cable	M12 connector	2 m cable	M12 connector
Flush mountable				
Dimensions (mm)	M12 x 47	M12 x 50	M12 x 67	M12 x 70
Thread (mm)	M12 x 1 x 30	M12 x 1 x 30	M12 x 1 x 50	M12 x 1 x 50
Operating frequency	2 kHz	2 kHz	2 kHz	2 kHz
Sensing distance (Sn)	2 mm	2 mm	2 mm	2 mm
References				
NPN-NO	ICB12S30F02NO	ICB12S30F02NOM1	ICB12L50F02NO	ICB12L50F02NOM1
PNP-NO	ICB12S30F02PO	ICB12S30F02POM1	ICB12L50F02PO	ICB12L50F02POM1
NPN-NC	ICB12S30F02NC	ICB12S30F02NCM1	ICB12L50F02NC	ICB12L50F02NCM1
PNP-NC	ICB12S30F02PC	ICB12S30F02PCM1	ICB12L50F02PC	ICB12L50F02PCM1

Non-flush mountable				
Dimensions (mm)	M12 x 51	M12 x 54	M12 x 71	M12 x 74
Thread (mm)	M12 x 1 x 30	M12 x 1 x 30	M12 x 1 x 50	M12 x 1 x 50
Operating frequency	2 kHz	2 kHz	2 kHz	2 kHz
Sensing distance (Sn)	4 mm	4 mm	4 mm	4 mm
References				
NPN-NO	ICB12S30N04NO	ICB12S30N04NOM1	ICB12L50N04NO	ICB12L50N04NOM1
PNP-NO	ICB12S30N04PO	ICB12S30N04POM1	ICB12L50N04PO	ICB12L50N04POM1
NPN-NC	ICB12S30N04NC	ICB12S30N04NCM1	ICB12L50N04NC	ICB12L50N04NCM1
PNP-NC	ICB12S30N04PC	ICB12S30N04PCM1	ICB12L50N04PC	ICB12L50N04PCM1





Characteristics flush and non-flush mountable





Rated operating voltage	10 - 36 VDC	10 - 36 VDC	10 - 36 VDC	10 - 36 VDC
Voltage drop	≤ 2.5 VDC @ 200 mA	≤ 2.5 VDC @ 200 mA	≤ 2.5 VDC @ 200 mA	≤ 2.5 VDC @ 200 mA
Degree of protection	IP67	IP67	IP67	IP67
Protection short-circuit (S) Reverse polarity (P) Transients (T)	SPT	SPT	SPT	SPT
Output current	< 200 mA @ 50°C ≤ 150 mA @ 50-70°C	< 200 mA @ 50°C ≤ 150 mA @ 50-70°C	< 200 mA @ 50°C ≤ 150 mA @ 50-70°C	< 200 mA @ 50°C ≤ 150 mA @ 50-70°C
Housing material	Nickel-plated brass	Nickel-plated brass	Nickel-plated brass	Nickel-plated brass
Operating temperature	-25°C to +70°C	-25°C to +70°C	-25°C to +70°C	-25°C to +70°C
LED colour	Yellow	Yellow	Yellow	Yellow
Approvals/Marks	CE - cULus - Cl. I Div. 2	CE - cULus - Cl. I Div. 2	CE - cULus - Cl. I Div. 2	CE - cULus - Cl. I Div. 2

Inductive proximity sensors, 3-wire, DC, extended range

Types	M12 Extended - Extra-short body	M12 Extended - Extra-short body
Connections	2 m cable	M12 connector
Flush mountable		
Dimensions (mm)	M12 x 25	M12 x 40
Thread (mm)	M12 x 1 x 23	M12 x 1 x 23
Operating frequency	2 kHz	2 kHz
Sensing distance (Sn)	4 mm	4 mm
References		
NPN-NO	ICB12S23F04A2NO	ICB12S23F04M1NO
PNP-NO	ICB12S23F04A2PO	ICB12S23F04M1PO
NPN-NC	ICB12S23F04A2NC	ICB12S23F04M1NC
PNP-NC	ICB12S23F04A2PC	ICB12S23F04M1PC
Non-flush mountable		
Dimensions (mm)	M12 x 29	M12 x 44
Thread (mm)	M12 x 1 x 23	M12 x 1 x 23
Operating frequency	2 kHz	2 kHz
Sensing distance (Sn)	8 mm	8 mm
References		
NPN-NO	ICB12S23N08A2NO	ICB12S23N08M1NO
PNP-NO	ICB12S23N08A2PO	ICB12S23N08M1PO
NPN-NC	ICB12S23N08A2NC	ICB12S23N08M1NC
PNP-NC	ICB12S23N08A2PC	ICB12S23N08M1PC
Characteristics quasi-flush and non-flush mountable		
Rated operating voltage	10 - 36 VDC	10 - 36 VDC
Voltage drop	≤ 2.5 VDC @ 200 mA	≤ 2.5 VDC @ 200 mA
Degree of protection	IP67	IP67
Protection short-circuit (S)		
Reverse polarity (P)	SPT	SPT
Transients (T)		
Output current	≤ 200 mA	≤ 200 mA
Housing material	Nickel-plated brass	Nickel-plated brass
Operating temperature	-25°C to +80°C	-25°C to +80°C
LED colour	Yellow	Yellow
Approvals/Marks	CE - cULus	CE - cULus





Inductive proximity sensors, 3-wire, DC, extended range





Types	M12 Extended - Short body		M12 Extended - Long body	
Connections	2 m cable	M12 connector	2 m cable	M12 connector
Flush mountable				
Dimensions (mm)	M12 x 47	M12 x 50	M12 x 67	M12 x 70
Thread (mm)	M12 x 1 x 30	M12 x 1 x 30	M12 x 1 x 50	M12 x 1 x 50
Operating frequency	2 kHz	2 kHz	2 kHz	2 kHz
Sensing distance (Sn)	4 mm	4 mm	4 mm	4 mm
References				
NPN-NO	ICB12S30F04NO	ICB12S30F04NOM1	ICB12L50F04NO	ICB12L50F04NOM1
PNP-NO	ICB12S30F04PO	ICB12S30F04POM1	ICB12L50F04PO	ICB12L50F04POM1
NPN-NC	ICB12S30F04NC	ICB12S30F04NCM1	ICB12L50F04NC	ICB12L50F04NCM1
PNP-NC	ICB12S30F04PC	ICB12S30F04PCM1	ICB12L50F04PC	ICB12L50F04PCM1

Non-flush mountable				
Dimensions (mm)	M12 x 51	M12 x 54	M12 x 71	M12 x 74
Thread (mm)	M12 x 1 x 30	M12 x 1 x 30	M12 x 1 x 50	M12 x 1 x 50
Operating frequency	2 kHz	2 kHz	2 kHz	2 kHz
Sensing distance (Sn)	8 mm	8 mm	8 mm	8 mm
References				
NPN-NO	ICB12S30N08NO	ICB12S30N08NOM1	ICB12L50N08NO	ICB12L50N08NOM1
PNP-NO	ICB12S30N08PO	ICB12S30N08POM1	ICB12L50N08PO	ICB12L50N08POM1
NPN-NC	ICB12S30N08NC	ICB12S30N08NCM1	ICB12L50N08NC	ICB12L50N08NCM1
PNP-NC	ICB12S30N08PC	ICB12S30N08PCM1	ICB12L50N08PC	ICB12L50N08PCM1

Characteristics flush and non-flush mountable				
Rated operating voltage	10 - 36 VDC	10 - 36 VDC	10 - 36 VDC	10 - 36 VDC
Voltage drop	≤ 2.5 VDC @ 200 mA	≤ 2.5 VDC @ 200 mA	≤ 2.5 VDC @ 200 mA	≤ 2.5 VDC @ 200 mA
Degree of protection	IP67	IP67	IP67	IP67
Protection short-circuit (S) Reverse polarity (P) Transients (T)	SPT	SPT	SPT	SPT
Output current	≤ 200 mA @ 50°C ≤ 150 mA @ 50-70°C	≤ 200 mA @ 50°C ≤ 150 mA @ 50-70°C	≤ 200 mA @ 50°C ≤ 150 mA @ 50-70°C	≤ 200 mA @ 50°C ≤ 150 mA @ 50-70°C
Housing material	Nickel-plated brass	Nickel-plated brass	Nickel-plated brass	Nickel-plated brass
Operating temperature	-25°C to +70°C	-25°C to +70°C	-25°C to +70°C	-25°C to +70°C
LED colour	Yellow	Yellow	Yellow	Yellow
Approvals/Marks	CE - cULus - Cl. I Div. 2	CE - cULus - Cl. I Div. 2	CE - cULus - Cl. I Div. 2	CE - cULus - Cl. I Div. 2









Inductive proximity sensors, 3-wire, DC, increased range

Types	M12 Increased - Short body		M12 Increased - Long body	
Connections	2 m cable	M12 connector	2 m cable	M12 connector
Quasi-flush mountable				
Dimensions (mm)	M12 x 48	M12 x 51	M12 x 68	M12 x 71
Thread (mm)	M12 x 1 x 30	M12 x 1 x 30	M12 x 1 x 50	M12 x 1 x 50
Operating frequency	2 kHz	2 kHz	2 kHz	2 kHz
Sensing distance (Sn)	6 mm	6 mm	6 mm	6 mm
References				
NPN-NO	ICB12S30F06NO	ICB12S30F06NOM1	ICB12L50F06NO	ICB12L50F06NOM1
PNP-NO	ICB12S30F06PO	ICB12S30F06POM1	ICB12L50F06PO	ICB12L50F06POM1
NPN-NC	ICB12S30F06NC	ICB12S30F06NCM1	ICB12L50F06NC	ICB12L50F06NCM1
PNP-NC	ICB12S30F06PC	ICB12S30F06PCM1	ICB12L50F06PC	ICB12L50F06PCM1





Non-flush mountable				
Dimensions (mm)	M12 x 51	M12 x 54	M12 x 71	M12 x 74
Thread (mm)	M12 x 1 x 30	M12 x 1 x 30	M12 x 1 x 50	M12 x 1 x 50
Operating frequency	2 kHz	2 kHz	2 kHz	2 kHz
Sensing distance (Sn)	10 mm	10 mm	10 mm	10 mm
References				
NPN-NO	ICB12S30N10NO	ICB12S30N10NOM1	ICB12L50N10NO	ICB12L50N10NOM1
PNP-NO	ICB12S30N10PO	ICB12S30N10POM1	ICB12L50N10PO	ICB12L50N10POM1
NPN-NC	ICB12S30N10NC	ICB12S30N10NCM1	ICB12L50N10NC	ICB12L50N10NCM1
PNP-NC	ICB12S30N10PC	ICB12S30N10PCM1	ICB12L50N10PC	ICB12L50N10PCM1





Characteristics quasi-flush and non-flush mountable				
Rated operating voltage	10 - 36 VDC	10 - 36 VDC	10 - 36 VDC	10 - 36 VDC
Voltage drop	≤ 2.5 VDC @ 200 mA	≤ 2.5 VDC @ 200 mA	≤ 2.5 VDC @ 200 mA	≤ 2.5 VDC @ 200 mA
Degree of protection	IP67	IP67	IP67	IP67
Protection short-circuit (S)				
Reverse polarity (P)	SPT	SPT	SPT	SPT
Transients (T)				
Output current	≤ 200 mA @ 50°C ≤ 150 mA @ 50-70°C	≤ 200 mA @ 50°C ≤ 150 mA @ 50-70°C	≤ 200 mA @ 50°C ≤ 150 mA @ 50-70°C	≤ 200 mA @ 50°C ≤ 150 mA @ 50-70°C
Housing material	Nickel-plated brass	Nickel-plated brass	Nickel-plated brass	Nickel-plated brass
Operating temperature	-25°C to +70°C	-25°C to +70°C	-25°C to +70°C	-25°C to +70°C
LED colour	Yellow	Yellow	Yellow	Yellow
Approvals/Marks	CE - cULus - Cl. I Div. 2	CE - cULus - Cl. I Div. 2	CE - cULus - Cl. I Div. 2	CE - cULus - Cl. I Div. 2

Inductive proximity sensors, 3-wire, DC

Types	M18 Standard - Short body		M18 Standard - Long body	
Connections	2 m cable	M12 connector	2 m cable	M12 connector
Flush mountable				
Dimensions (mm)	M18 x 53	M18 x 54	M18 x 73	M18 x 74
Thread (mm)	M18 x 1 x 30	M18 x 1 x 30	M18 x 1 x 50	M18 x 1 x 50
Operating frequency	1.5 kHz	1.5 kHz	1.5 kHz	1.5 kHz
Sensing distance (Sn)	5 mm	5 mm	5 mm	5 mm
References				
NPN-NO	ICB18S30F05NO	ICB18S30F05NOM1	ICB18L50F05NO	ICB18L50F05NOM1
PNP-NO	ICB18S30F05PO	ICB18S30F05POM1	ICB18L50F05PO	ICB18L50F05POM1
NPN-NC	ICB18S30F05NC	ICB18S30F05NCM1	ICB18L50F05NC	ICB18L50F05NCM1
PNP-NC	ICB18S30F05PC	ICB18S30F05PCM1	ICB18L50F05PC	ICB18L50F05PCM1
Non-flush mountable				
Dimensions (mm)	M18 x 63	M18 x 64	M18 x 83	M18 x 84
Thread (mm)	M18 x 1 x 30	M18 x 1 x 30	M18 x 1 x 50	M18 x 1 x 50
Operating frequency	1.5 kHz	1.5 kHz	1.5 kHz	1.5 kHz
Sensing distance (Sn)	8 mm	8 mm	8 mm	8 mm
References				
NPN-NO	ICB18S30N08NO	ICB18S30N08NOM1	ICB18L50N08NO	ICB18L50N08NOM1
PNP-NO	ICB18S30N08PO	ICB18S30N08POM1	ICB18L50N08PO	ICB18L50N08POM1
NPN-NC	ICB18S30N08NC	ICB18S30N08NCM1	ICB18L50N08NC	ICB18L50N08NCM1
PNP-NC	ICB18S30N08PC	ICB18S30N08PCM1	ICB18L50N08PC	ICB18L50N08PCM1
Characteristics flush and non-flush mountable				
Rated operating voltage	10 - 36 VDC	10 - 36 VDC	10 - 36 VDC	10 - 36 VDC
Voltage drop	≤ 2.5 VDC @ 200 mA	≤ 2.5 VDC @ 200 mA	≤ 2.5 VDC @ 200 mA	≤ 2.5 VDC @ 200 mA
Degree of protection	IP67	IP67	IP67	IP67
Protection short-circuit (S)				
Reverse polarity (P)	SPT	SPT	SPT	SPT
Transients (T)				
Output current	≤ 200 mA @ 50°C ≤ 150 mA @ 50-70°C	≤ 200 mA @ 50°C ≤ 150 mA @ 50-70°C	≤ 200 mA @ 50°C ≤ 150 mA @ 50-70°C	≤ 200 mA @ 50°C ≤ 150 mA @ 50-70°C
Housing material	Nickel-plated brass	Nickel-plated brass	Nickel-plated brass	Nickel-plated brass
Operating temperature	-25°C to +70°C	-25°C to +70°C	-25°C to +70°C	-25°C to +70°C
LED colour	Yellow	Yellow	Yellow	Yellow
Approvals/Marks	CE - cULus - Cl. I Div. 2	CE - cULus - Cl. I Div. 2	CE - cULus - Cl. I Div. 2	CE - cULus - Cl. I Div. 2





Inductive proximity sensors, 3-wire, DC, extended range





Types	M18 Extended - Short body		M18 Extended - Long body	
Connections	2 m cable	M12 connector	2 m cable	M12 connector
Flush mountable				
Dimensions (mm)	M18 x 53	M18 x 54	M18 x 73	M18 x 74
Thread (mm)	M18 x 1 x 30	M18 x 1 x 30	M18 x 1 x 50	M18 x 1 x 50
Operating frequency	1.5 kHz	1.5 kHz	1.5 kHz	1.5 kHz
Sensing distance (Sn)	8 mm	8 mm	8 mm	8 mm
References				
NPN-NO	ICB18S30F08NO	ICB18S30F08NOM1	ICB18L50F08NO	ICB18L50F08NOM1
PNP-NO	ICB18S30F08PO	ICB18S30F08POM1	ICB18L50F08PO	ICB18L50F08POM1
NPN-NC	ICB18S30F08NC	ICB18S30F08NCM1	ICB18L50F08NC	ICB18L50F08NCM1
PNP-NC	ICB18S30F08PC	ICB18S30F08PCM1	ICB18L50F08PC	ICB18L50F08PCM1

Non-flush mountable				
Dimensions (mm)	M18 x 63	M18 x 64	M18 x 83	M18 x 84
Thread (mm)	M18 x 1 x 30	M18 x 1 x 30	M18 x 1 x 50	M18 x 1 x 50
Operating frequency	1.5 kHz	1.5 kHz	1.5 kHz	1.5 kHz
Sensing distance (Sn)	14 mm	14 mm	14 mm	14 mm
References				
NPN-NO	ICB18S30N14NO	ICB18S30N14NOM1	ICB18L50N14NO	ICB18L50N14NOM1
PNP-NO	ICB18S30N14PO	ICB18S30N14POM1	ICB18L50N14PO	ICB18L50N14POM1
NPN-NC	ICB18S30N14NC	ICB18S30N14NCM1	ICB18L50N14NC	ICB18L50N14NCM1
PNP-NC	ICB18S30N14PC	ICB18S30N14PCM1	ICB18L50N14PC	ICB18L50N14PCM1

Characteristics flush and non-flush mountable				
Rated operating voltage	10 - 36 VDC	10 - 36 VDC	10 - 36 VDC	10 - 36 VDC
Voltage drop	≤ 2.5 VDC @ 200 mA	≤ 2.5 VDC @ 200 mA	≤ 2.5 VDC @ 200 mA	≤ 2.5 VDC @ 200 mA
Degree of protection	IP67	IP67	IP67	IP67
Protection short-circuit (S)				
Reverse polarity (P)	SPT	SPT	SPT	SPT
Transients (T)				
Output current	≤ 200 mA @ 50°C ≤ 150 mA @ 50-70°C	≤ 200 mA @ 50°C ≤ 150 mA @ 50-70°C	≤ 200 mA @ 50°C ≤ 150 mA @ 50-70°C	≤ 200 mA @ 50°C ≤ 150 mA @ 50-70°C
Housing material	Nickel-plated brass	Nickel-plated brass	Nickel-plated brass	Nickel-plated brass
Operating temperature	-25°C to +70°C	-25°C to +70°C	-25°C to +70°C	-25°C to +70°C
LED colour	Yellow	Yellow	Yellow	Yellow
Approvals/Marks	CE - cULus - Cl. I Div. 2	CE - cULus - Cl. I Div. 2	CE - cULus - Cl. I Div. 2	CE - cULus - Cl. I Div. 2









Inductive proximity sensors, 3-wire, DC, increased range

Types	M18 Increased - Short body		M18 Increased - Long body	
Connections	2 m cable	M12 connector	2 m cable	M12 connector
Quasi-flush mountable				
Dimensions (mm)	M18 x 54	M18 x 55	M18 x 74	M18 x 75
Thread (mm)	M18 x 1 x 30	M18 x 1 x 30	M18 x 1 x 50	M18 x 1 x 50
Operating frequency	1 kHz	1 kHz	1 kHz	1 kHz
Sensing distance (Sn)	12 mm	12 mm	12 mm	12 mm
References				
NPN-NO	ICB18S30F12NO	ICB18S30F12NOM1	ICB18L50F12NO	ICB18L50F12NOM1
PNP-NO	ICB18S30F12PO	ICB18S30F12POM1	ICB18L50F12PO	ICB18L50F12POM1
NPN-NC	ICB18S30F12NC	ICB18S30F12NCM1	ICB18L50F12NC	ICB18L50F12NCM1
PNP-NC	ICB18S30F12PC	ICB18S30F12PCM1	ICB18L50F12PC	ICB18L50F12PCM1





Non-flush mountable				
Dimensions (mm)	M18 x 63	M18 x 64	M18 x 83	M18 x 84
Thread (mm)	M18 x 1 x 30	M18 x 1 x 30	M18 x 1 x 50	M18 x 1 x 50
Operating frequency	1 kHz	1 kHz	1 kHz	1 kHz
Sensing distance (Sn)	20 mm	20 mm	20 mm	20 mm
References				
NPN-NO	ICB18S30N20NO	ICB18S30N20NOM1	ICB18L50N20NO	ICB18L50N20NOM1
PNP-NO	ICB18S30N20PO	ICB18S30N20POM1	ICB18L50N20PO	ICB18L50N20POM1
NPN-NC	ICB18S30N20NC	ICB18S30N20NCM1	ICB18L50N20NC	ICB18L50N20NCM1
PNP-NC	ICB18S30N20PC	ICB18S30N20PCM1	ICB18L50N20PC	ICB18L50N20PCM1





Characteristics quasi-flush and non-flush mountable				
Rated operating voltage	10 - 36 VDC	10 - 36 VDC	10 - 36 VDC	10 - 36 VDC
Voltage drop	≤ 2.5 VDC @ 200 mA	≤ 2.5 VDC @ 200 mA	≤ 2.5 VDC @ 200 mA	≤ 2.5 VDC @ 200 mA
Degree of protection	IP67	IP67	IP67	IP67
Protection short-circuit (S)				
Reverse polarity (P)	SPT	SPT	SPT	SPT
Transients (T)				
Output current	≤ 200 mA @ 50°C ≤ 150 mA @ 50-70°C	≤ 200 mA @ 50°C ≤ 150 mA @ 50-70°C	≤ 200 mA @ 50°C ≤ 150 mA @ 50-70°C	≤ 200 mA @ 50°C ≤ 150 mA @ 50-70°C
Housing material	Nickel-plated brass	Nickel-plated brass	Nickel-plated brass	Nickel-plated brass
Operating temperature	-25°C to +70°C	-25°C to +70°C	-25°C to +70°C	-25°C to +70°C
LED colour	Yellow	Yellow	Yellow	Yellow
Approvals/Marks	CE - cULus - Cl. I Div. 2	CE - cULus - Cl. I Div. 2	CE - cULus - Cl. I Div. 2	CE - cULus - Cl. I Div. 2

Inductive proximity sensors, 3-wire, DC

Types	M30 Standard - Short body		M30 Standard - Long body	
Connections	2 m cable	M12 connector	2 m cable	M12 connector
Flush mountable				
Dimensions (mm)	M30 x 43.6	M30 x 55	M30 x 63.6	M30 x 75
Thread (mm)	M30 x 1.5 x 30	M30 x 1.5 x 30	M30 x 1.5 x 50	M30 x 1.5 x 50
Operating frequency	1 kHz	1 kHz	1 kHz	1 kHz
Sensing distance (Sn)	10 mm	10 mm	10 mm	10 mm
References				
NPN-NO	ICB30S30F10NO	ICB30S30F10NOM1	ICB30L50F10NO	ICB30L50F10NOM1
PNP-NO	ICB30S30F10PO	ICB30S30F10POM1	ICB30L50F10PO	ICB30L50F10POM1
NPN-NC	ICB30S30F10NC	ICB30S30F10NCM1	ICB30L50F10NC	ICB30L50F10NCM1
PNP-NC	ICB30S30F10PC	ICB30S30F10PCM1	ICB30L50F10PC	ICB30L50F10PCM1
Non-flush mountable				
Dimensions (mm)	M30 x 55.6	M30 x 67	M30 x 75.6	M30 x 87
Thread (mm)	M30 x 1.5 x 30	M30 x 1.5 x 30	M30 x 1.5 x 50	M30 x 1.5 x 50
Operating frequency	1 kHz	1 kHz	1 kHz	1 kHz
Sensing distance (Sn)	15 mm	15 mm	15 mm	15 mm
References				
NPN-NO	ICB30S30N15NO	ICB30S30N15NOM1	ICB30L50N15NO	ICB30L50N15NOM1
PNP-NO	ICB30S30N15PO	ICB30S30N15POM1	ICB30L50N15PO	ICB30L50N15POM1
NPN-NC	ICB30S30N15NC	ICB30S30N15NCM1	ICB30L50N15NC	ICB30L50N15NCM1
PNP-NC	ICB30S30N15PC	ICB30S30N15PCM1	ICB30L50N15PC	ICB30L50N15PCM1
Characteristics flush and non-flush mountable				
Rated operating voltage	10 - 36 VDC	10 - 36 VDC	10 - 36 VDC	10 - 36 VDC
Voltage drop	≤ 2.5 VDC @ 200 mA	≤ 2.5 VDC @ 200 mA	≤ 2.5 VDC @ 200 mA	≤ 2.5 VDC @ 200 mA
Degree of protection	IP67	IP67	IP67	IP67
Protection short-circuit (S)				
Reverse polarity (P)	SPT	SPT	SPT	SPT
Transients (T)				
Output current	≤ 200 mA @ 50°C ≤ 150 mA @ 50-70°C	≤ 200 mA @ 50°C ≤ 150 mA @ 50-70°C	≤ 200 mA @ 50°C ≤ 150 mA @ 50-70°C	≤ 200 mA @ 50°C ≤ 150 mA @ 50-70°C
Housing material	Nickel-plated brass	Nickel-plated brass	Nickel-plated brass	Nickel-plated brass
Operating temperature	-25°C to +70°C	-40°C to +70°C	-25°C to +70°C	-40°C to +70°C
LED colour	Yellow	Yellow	Yellow	Yellow
Approvals/Marks	CE - cULus - Cl. I Div. 2	CE - cULus - Cl. I Div. 2	CE - cULus - Cl. I Div. 2	CE - cULus - Cl. I Div. 2





Inductive proximity sensors, 3-wire, DC, extended range





Types	M30 Extended - Short body		M30 Extended - Long body	
Connections	2 m cable	M12 connector	2 m cable	M12 connector
Flush mountable				
Dimensions (mm)	M30 x 43.6	M30 x 55	M30 x 63.6	M30 x 75
Thread (mm)	M30 x 1.5 x 30	M30 x 1.5 x 30	M30 x 1.5 x 50	M30 x 1.5 x 50
Operating frequency	1 kHz	1 kHz	1 kHz	1 kHz
Sensing distance (Sn)	15 mm	15 mm	15 mm	15 mm
References				
NPN-NO	ICB30S30F15NO	ICB30S30F15NOM1	ICB30L50F15NO	ICB30L50F15NOM1
PNP-NO	ICB30S30F15PO	ICB30S30F15POM1	ICB30L50F15PO	ICB30L50F15POM1
NPN-NC	ICB30S30F15NC	ICB30S30F15NCM1	ICB30L50F15NC	ICB30L50F15NCM1
PNP-NC	ICB30S30F15PC	ICB30S30F15PCM1	ICB30L50F15PC	ICB30L50F15PCM1

Non-flush mountable				
Dimensions (mm)	M30 x 55.6	M30 x 67	M30 x 75.6	M30 x 87
Thread (mm)	M30 x 1.5 x 30	M30 x 1.5 x 30	M30 x 1.5 x 50	M30 x 1.5 x 50
Operating frequency	1 kHz	1 kHz	1 kHz	1 kHz
Sensing distance (Sn)	22 mm	22 mm	22 mm	22 mm
References				
NPN-NO	ICB30S30N22NO	ICB30S30N22NOM1	ICB30L50N22NO	ICB30L50N22NOM1
PNP-NO	ICB30S30N22PO	ICB30S30N22POM1	ICB30L50N22PO	ICB30L50N22POM1
NPN-NC	ICB30S30N22NC	ICB30S30N22NCM1	ICB30L50N22NC	ICB30L50N22NCM1
PNP-NC	ICB30S30N22PC	ICB30S30N22PCM1	ICB30L50N22PC	ICB30L50N22PCM1

Characteristics flush and non-flush mountable				
Rated operating voltage	10 - 36 VDC	10 - 36 VDC	10 - 36 VDC	10 - 36 VDC
Voltage drop	≤ 2.5 VDC @ 200 mA	≤ 2.5 VDC @ 200 mA	≤ 2.5 VDC @ 200 mA	≤ 2.5 VDC @ 200 mA
Degree of protection	IP67	IP67	IP67	IP67
Protection short-circuit (S)				
Reverse polarity (P)	SPT	SPT	SPT	SPT
Transients (T)				
Output current	≤ 200 mA @ 50°C ≤ 150 mA @ 50-70°C	≤ 200 mA @ 50°C ≤ 150 mA @ 50-70°C	≤ 200 mA @ 50°C ≤ 150 mA @ 50-70°C	≤ 200 mA @ 50°C ≤ 150 mA @ 50-70°C
Housing material	Nickel-plated brass	Nickel-plated brass	Nickel-plated brass	Nickel-plated brass
Operating temperature	-25°C to +70°C	-40°C to +70°C	-25°C to +70°C	-40°C to +70°C
LED colour	Yellow	Yellow	Yellow	Yellow
Approvals/Marks	CE - cULus - Cl. I Div. 2	CE - cULus - Cl. I Div. 2	CE - cULus - Cl. I Div. 2	CE - cULus - Cl. I Div. 2

Inductive proximity sensors, 3-wire, DC, increased range

Types	M30 Increased - Short body		M30 Increased - Long body	
Connections	2 m cable	M12 connector	2 m cable	M12 connector
Quasi-flush mountable				
Dimensions (mm)	M30 x 35	M30 x 60	M30 x 50	M30 x 75
Thread (mm)	M30 x 1.5 x 35	M30 x 1.5 x 35	M30 x 1.5 x 50	M30 x 1.5 x 50
Operating frequency	100 Hz	100 Hz	100 Hz	100 Hz
Sensing distance (Sn)	22 mm	22 mm	22 mm	22 mm
References				
NPN-NO	ICB30S35F22NO	ICB30S35F22NOM1	ICB30L50F22NO	ICB30L50F22NOM1
PNP-NO	ICB30S35F22PO	ICB30S35F22POM1	ICB30L50F22PO	ICB30L50F22POM1
NPN-NC	ICB30S35F22NC	ICB30S35F22NCM1	ICB30L50F22NC	ICB30L50F22NCM1
PNP-NC	ICB30S35F22PC	ICB30S35F22PCM1	ICB30L50F22PC	ICB30L50F22PCM1





Non-flush mountable				
Dimensions (mm)	M30 x 47	M30 x 72	M30 x 62	M30 x 87
Thread (mm)	M30 x 1.5 x 35	M30 x 1.5 x 35	M30 x 1.5 x 50	M30 x 1.5 x 50
Operating frequency	100 Hz	100 Hz	100 Hz	100 Hz
Sensing distance (Sn)	40 mm	40 mm	40 mm	40 mm
References				
NPN-NO	ICB30S35N40NO	ICB30S35N40NOM1	ICB30L50N40NO	ICB30L50N40NOM1
PNP-NO	ICB30S35N40PO	ICB30S35N40POM1	ICB30L50N40PO	ICB30L50N40POM1
NPN-NC	ICB30S35N40NC	ICB30S35N40NCM1	ICB30L50N40NC	ICB30L50N40NCM1
PNP-NC	ICB30S35N40PC	ICB30S35N40PCM1	ICB30L50N40PC	ICB30L50N40PCM1

Characteristics quasi-flush and non-flush mountable				
Rated operating voltage	10 - 36 VDC	10 - 36 VDC	10 - 36 VDC	10 - 36 VDC
Voltage drop	≤ 2.5 VDC @ 200 mA	≤ 2.5 VDC @ 200 mA	≤ 2.5 VDC @ 200 mA	≤ 2.5 VDC @ 200 mA
Degree of protection	IP67	IP67	IP67	IP67
Protection short-circuit (S)				
Reverse polarity (P)	SPT	SPT	SPT	SPT
Transients (T)				
Output current	≤ 200 mA @ 50°C ≤ 150 mA @ 50-70°C	≤ 200 mA @ 50°C ≤ 150 mA @ 50-70°C	≤ 200 mA @ 50°C ≤ 150 mA @ 50-70°C	≤ 200 mA @ 50°C ≤ 150 mA @ 50-70°C
Housing material	Nickel-plated brass	Nickel-plated brass	Nickel-plated brass	Nickel-plated brass
Operating temperature	-25°C to +70°C	-25°C to +70°C	-25°C to +70°C	-25°C to +70°C
LED colour	Yellow	Yellow	Yellow	Yellow
Approvals/Marks	CE - cULus - Cl. I Div. 2	CE - cULus - Cl. I Div. 2	CE - cULus - Cl. I Div. 2	CE - cULus - Cl. I Div. 2

Inductive proximity sensors, 3-wire, DC, washdown IP69K

Types	M12 Standard - Long body	M12 Extended - Long body	M18 Standard - Long body	M18 Extended - Long body
-------	--------------------------	--------------------------	--------------------------	--------------------------

Connections	M12 connector	M12 connector	M12 connector	M12 connector
-------------	---------------	---------------	---------------	---------------

Flush mountable				
------------------------	---	---	--	---

Dimensions (mm)	M12 x 64.8	M12 x 64.8	M18 x 63	M18 x 63
Thread (mm)	M12 x 1 x 38.7	M12 x 1 x 38.7	M12 x 1 x 35	M12 x 1 x 35
Operating frequency	2 kHz	2 kHz	1.5 kHz	1.5 kHz
Sensing distance (Sn)	2 mm	4 mm	5 mm	8 mm

References

NPN-NO	ICS12LF02NOM1-FB	ICS12LF04NOM1-FB	ICS18LF05NOM1-FB	ICS18LF08NOM1-FB
PNP-NO	ICS12LF02POM1-FB	ICS12LF04POM1-FB	ICS18LF05POM1-FB	ICS18LF08POM1-FB
NPN-NC	ICS12LF02NCM1-FB	ICS12LF04NCM1-FB	ICS18LF05NCM1-FB	ICS18LF08NCM1-FB
PNP-NC	ICS12LF02PCM1-FB	ICS12LF04PCM1-FB	ICS18LF05PCM1-FB	ICS18LF08PCM1-FB

Non-flush mountable				
----------------------------	---	---	--	---

Dimensions (mm)	M12 x 64.8	M12 x 64.8	M18 x 63	M18 x 63
Thread (mm)	M12 x 1 x 32.5	M12 x 1 x 32.5	M12 x 1 x 27	M12 x 1 x 27
Operating frequency	2 kHz	2 kHz	1.5 kHz	1.5 kHz
Sensing distance (Sn)	4 mm	8 mm	8 mm	12 mm

References





NPN-NO	ICS12LN04NOM1-FB	ICS12LN08NOM1-FB	ICS18LN08NOM1-FB	ICS18LN12NOM1-FB
PNP-NO	ICS12LN04POM1-FB	ICS12LN08POM1-FB	ICS18LN08POM1-FB	ICS18LN12POM1-FB
NPN-NC	ICS12LN04NCM1-FB	ICS12LN08NCM1-FB	ICS18LN08NCM1-FB	ICS18LN12NCM1-FB
PNP-NC	ICS12LN04PCM1-FB	ICS12LN08PCM1-FB	ICS18LN08PCM1-FB	ICS18LN12PCM1-FB

Characteristics flush and non-flush mountable

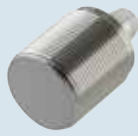
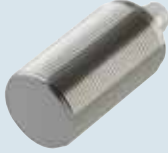
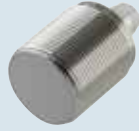
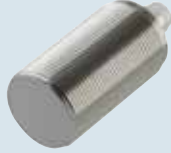
Rated operating voltage	10 - 36 VDC	10 - 36 VDC	10 - 36 VDC	10 - 36 VDC
Voltage drop	≤ 2.5 VDC @ 200 mA	≤ 2.5 VDC @ 200 mA	≤ 2.5 VDC @ 200 mA	≤ 2.5 VDC @ 200 mA
Degree of protection	IP67, IP68, IP69K	IP67, IP68, IP69K	IP67, IP68, IP69K	IP67, IP68, IP69K
Protection short-circuit (S)				
Reverse polarity (P)	SPT	SPT	SPT	SPT
Transients (T)				
Output current	≤ 200 mA @ 50°C ≤ 150 mA @ 50-80°C	≤ 200 mA @ 50°C ≤ 150 mA @ 50-80°C	≤ 200 mA @ 50°C ≤ 150 mA @ 50-80°C	≤ 200 mA @ 50°C ≤ 150 mA @ 50-80°C
Housing material	Stainless steel (AISI 316L)	Stainless steel (AISI 316L)	Stainless steel (AISI 316L)	Stainless steel (AISI 316L)
Front cap material	PPS grey - FDA certified	PPS grey - FDA certified	PPS grey - FDA certified	PPS grey - FDA certified
Operating temperature	-40°C to +80°C	-40°C to +80°C	-40°C to +80°C	-40°C to +80°C
LED colour	Yellow	Yellow	Yellow	Yellow
Approvals/Marks	CE - cULus - ECOLAB - Cl. I Div. 2	CE - cULus - ECOLAB - Cl. I Div. 2	CE - cULus - ECOLAB - Cl. I Div. 2	CE - cULus - ECOLAB - Cl. I Div. 2

Inductive proximity sensors, 3-wire, DC, washdown IP69K







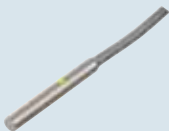

Types	M30 Standard		M30 Extended	
	Short body	Long body	Short body	Long body
Connections	M12 connector	M12 connector	M12 connector	M12 connector
Flush mountable				
Dimensions (mm)	M30 x 47	M30 x 67.5	M30 x 47	M30 x 67.5
Thread (mm)	M30 x 1.5 x 30	M30 x 1.5 x 50	M30 x 1.5 x 30	M30 x 1.5 x 50
Operating frequency	1 kHz	1 kHz	1 kHz	1 kHz
Sensing distance (Sn)	10 mm	10 mm	15 mm	15 mm
References				
NPN-NO	ICS30SF10NOM1-FB	ICS30LF10NOM1-FB	ICS30SF15NOM1-FB	ICS30LF15NOM1-FB
PNP-NO	ICS30SF10POM1-FB	ICS30LF10POM1-FB	ICS30SF15POM1-FB	ICS30LF15POM1-FB
NPN-NC	ICS30SF10NCM1-FB	ICS30LF10NCM1-FB	ICS30SF15NCM1-FB	ICS30LF15NCM1-FB
PNP-NC	ICS30SF10PCM1-FB	ICS30LF10PCM1-FB	ICS30SF15PCM1-FB	ICS30LF15PCM1-FB

Non-flush mountable				
Dimensions (mm)	M30 x 59.5	M30 x 79.5	M30 x 59.5	M30 x 79.5
Thread (mm)	M30 x 1.5 x 30	M30 x 1.5 x 50	M30 x 1.5 x 30	M30 x 1.5 x 50
Operating frequency	1 kHz	1 kHz	1 kHz	1 kHz
Sensing distance (Sn)	15 mm	15 mm	22 mm	22 mm
References				
NPN-NO	ICS30SN15NOM1-FB	ICS30LN15NOM1-FB	ICS30SN22NOM1-FB	ICS30LN22NOM1-FB
PNP-NO	ICS30SN15POM1-FB	ICS30LN15POM1-FB	ICS30SN22POM1-FB	ICS30LN22POM1-FB
NPN-NC	ICS30SN15NCM1-FB	ICS30LN15NCM1-FB	ICS30SN22NCM1-FB	ICS30LN22NCM1-FB
PNP-NC	ICS30SN15PCM1-FB	ICS30LN15PCM1-FB	ICS30SN22PCM1-FB	ICS30LN22PCM1-FB

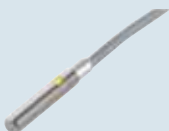

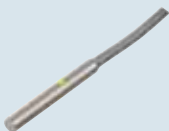

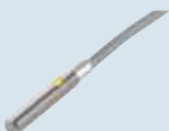
Characteristics flush and non-flush mountable

Rated operating voltage	10 - 36 VDC	10 - 36 VDC	10 - 36 VDC	10 - 36 VDC
Voltage drop	≤ 2 VDC @ 200 mA	≤ 2 VDC @ 200 mA	≤ 2 VDC @ 200 mA	≤ 2 VDC @ 200 mA
Degree of protection	IP67, IP68, IP69K	IP67, IP68, IP69K	IP67, IP68, IP69K	IP67, IP68, IP69K
Protection short-circuit (S)				
Reverse polarity (P)	SPT	SPT	SPT	SPT
Transients (T)				
Output current	≤ 200 mA @ 50°C ≤ 150 mA @ 50-80°C ≤ 100 mA @ 80-85°C	≤ 200 mA @ 50°C ≤ 150 mA @ 50-80°C ≤ 100 mA @ 80-85°C	≤ 200 mA @ 50°C ≤ 150 mA @ 50-80°C ≤ 100 mA @ 80-85°C	≤ 200 mA @ 50°C ≤ 150 mA @ 50-80°C ≤ 100 mA @ 80-85°C
Housing material	Stainless steel (AISI 316L)	Stainless steel (AISI 316L)	Stainless steel (AISI 316L)	Stainless steel (AISI 316L)
Front cap material	PPS grey - FDA certified	PPS grey - FDA certified	PPS grey - FDA certified	PPS grey - FDA certified
Operating temperature	-40°C to +85°C	-40°C to +85°C	-40°C to +85°C	-40°C to +85°C
LED colour	Yellow	Yellow	Yellow	Yellow
Approvals/Marks	CE - cULus - ECOLAB - Cl. I Div. 2	CE - cULus - ECOLAB - Cl. I Div. 2	CE - cULus - ECOLAB - Cl. I Div. 2	CE - cULus - ECOLAB - Cl. I Div. 2

Inductive proximity sensors, 3-wire, DC

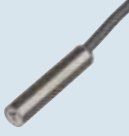
Types	Ø4 Standard & Extended Short body		M5 Standard & Extended Short body	
	2 m cable	M8 connector	2 m cable	M8 connector
Flush mountable - Standard				
Dimensions (mm)	Ø4 x 28.2	Ø4 x 38.2	M5 x 28.2	M5 x 38.2
Thread (mm)	-	-	M5 x 0.5 x 23	M5 x 0.5 x 23
Operating frequency	6 kHz	6 kHz	6 kHz	6 kHz
Sensing distance (Sn)	0.8 mm	0.8 mm	0.8 mm	0.8 mm
References				
NPN-NO	IBS04SF08A2NO	IBS04SF08M5NO	ICS05S23F08A2NO	ICS05S23F08M5NO
PNP-NO	IBS04SF08A2PO	IBS04SF08M5PO	ICS05S23F08A2PO	ICS05S23F08M5PO
NPN-NC	IBS04SF08A2NC	IBS04SF08M5NC	ICS05S23F08A2NC	ICS05S23F08M5NC
PNP-NC	IBS04SF08A2PC	IBS04SF08M5PC	ICS05S23F08A2PC	ICS05S23F08M5PC
Flush mountable - Extended				
Dimensions (mm)	Ø4 x 28.2	Ø4 x 38.2	M5 x 28.2	M5 x 38.2
Thread (mm)	-	-	M5 x 0.5 x 23	M5 x 0.5 x 23
Operating frequency	4.5 kHz	4.5 kHz	4.5 kHz	4.5 kHz
Sensing distance (Sn)	1.3 mm	1.3 mm	1.3 mm	1.3 mm
References				
NPN-NO	IBS04SF15A2NO	IBS04SF15M5NO	ICS05S23F15A2NO	ICS05S23F15M5NO
PNP-NO	IBS04SF15A2PO	IBS04SF15M5PO	ICS05S23F15A2PO	ICS05S23F15M5PO
NPN-NC	IBS04SF15A2NC	IBS04SF15M5NC	ICS05S23F15A2NC	ICS05S23F15M5NC
PNP-NC	IBS04SF15A2PC	IBS04SF15M5PC	ICS05S23F15A2PC	ICS05S23F15M5PC
Characteristics				
Rated operating voltage	10 - 30 VDC	10 - 30 VDC	10 - 30 VDC	10 - 30 VDC
Voltage drop	max. 1.2 VDC (@ 100 mA)	max. 1.2 VDC (@ 100 mA)	max. 1.2 VDC (@ 100 mA)	max. 1.2 VDC (@ 100 mA)
Degree of protection	IP67	IP67	IP67	IP67
Protection short-circuit (S)				
Reverse polarity (P)	SPT	SPT	SPT	SPT
Transients (T)				
Output current	≤ 100 mA	≤ 100 mA	≤ 100 mA	≤ 100 mA
Housing material	Stainless steel	Stainless steel	Stainless steel	Stainless steel
Operating temperature	-25°C to +70°C	-25°C to +70°C	-25°C to +70°C	-25°C to +70°C
LED colour	Yellow	Yellow	Yellow	Yellow
Approvals/Marks	CE - UL - CSA	CE - UL - CSA	CE - UL - CSA	CE - UL - CSA

Inductive proximity sensors, 3-wire, DC

Types	Ø6.5 Extended - Short body		Ø6.5 Extended - Long body	
Connections	2 m cable	M8 connector	2 m cable	M8 connector
Flush mountable				
Dimensions (mm)	Ø6.5 x 31	Ø6.5 x 40	Ø6.5 x 46	Ø6.5 x 55
Thread (mm)	-	-	-	-
Operating frequency	2 kHz	2 kHz	2 kHz	2 kHz
Sensing distance (Sn)	2 mm	2 mm	2 mm	2 mm
References				
NPN-NO	IBS06SF02NO	IBS06SF02NOM5	IBS06LF02NO	IBS06LF02NOM5
PNP-NO	IBS06SF02PO	IBS06SF02POM5	IBS06LF02PO	IBS06LF02POM5
NPN-NC	IBS06SF02NC	IBS06SF02NCM5	IBS06LF02NC	IBS06LF02NCM5
PNP-NC	IBS06SF02PC	IBS06SF02PCM5	IBS06LF02PC	IBS06LF02PCM5
Characteristics flush and non-flush mountable				
Rated operating voltage	10 - 36 VDC	10 - 36 VDC	10 - 36 VDC	10 - 36 VDC
Voltage drop	max. 1.6 VDC (@ 200 mA)	max. 1.6 VDC (@ 200 mA)	max. 1.6 VDC (@ 200 mA)	max. 1.6 VDC (@ 200 mA)
Degree of protection	IP67	IP67	IP67	IP67
Protection short-circuit (S)				
Reverse polarity (P)	SPT	SPT	SPT	SPT
Transients (T)				
Output current	≤ 200 mA @ 50°C; ≤ 150 mA @ 50-80°C	≤ 200 mA @ 50°C; ≤ 150 mA @ 50-80°C	≤ 200 mA @ 50°C; ≤ 150 mA @ 50-80°C	≤ 200 mA @ 50°C; ≤ 150 mA @ 50-80°C
Housing material	Stainless steel	Stainless steel	Stainless steel	Stainless steel
Operating temperature	-25°C to +80°C	-25°C to +80°C	-25°C to +80°C	-25°C to +80°C
LED colour	Yellow	Yellow	Yellow	Yellow
Approvals/Marks	CE - cULus	CE - cULus	CE - cULus	CE - cULus

Inductive proximity sensors, 3-wire, DC

Types M8 Standard - Short body

Connections 2 m cable M8 connector M12 connector

Flush mountable



Dimensions (mm)	M8 x 31	M8 x 40	M8 x 53.6
Thread (mm)	M8 x 1 x 30	M8 x 1 x 29	M8 x 1 x 29
Operating frequency	2 kHz	2 kHz	2 kHz
Sensing distance (Sn)	1 mm	1 mm	1.5 mm

References

NPN-NO	ICS08S30F01NO	ICS08S30F01NOM5	
PNP-NO	ICS08S30F01PO	ICS08S30F01POM5	ICS08S30F15POM1
NPN-NC	ICS08S30F01NC	ICS08S30F01NCM5	
PNP-NC	ICS08S30F01PC	ICS08S30F01PCM5	

Flush mountable - Extended



Dimensions (mm)	M8 x 34	M8 x 43	M8 x 56.6
Thread (mm)	M8 x 1 x 30	M8 x 1 x 29	M8 x 1 x 29
Operating frequency	2 kHz	2 kHz	2 kHz
Sensing distance (Sn)	2 mm	2 mm	2.5 mm

References

NPN-NO	ICS08S30N02NO	ICS08S30N02NOM5	
PNP-NO	ICS08S30N02PO	ICS08S30N02POM5	ICS08S30N25POM1
NPN-NC	ICS08S30N02NC	ICS08S30N02NCM5	
PNP-NC	ICS08S30N02PC	ICS08S30N02PCM5	

Characteristics

Rated operating voltage	10 - 36 VDC	10 - 36 VDC	10 - 36 VDC
Voltage drop	max. 1.6 VDC (@ 200 mA)	max. 1.6 VDC (@ 200 mA)	max. 1.6 VDC (@ 200 mA)
Degree of protection	IP67	IP67	IP67
Protection short-circuit (S) Reverse polarity (P) Transients (T)	SPT	SPT	SPT
Output current	≤ 200 mA @ 50°C; ≤ 150 mA @ 50-80°C	≤ 200 mA @ 50°C; ≤ 150 mA @ 50-80°C	≤ 200 mA @ 50°C; ≤ 150 mA @ 50-80°C
Housing material	Stainless steel	Stainless steel	Stainless steel
Operating temperature	-25°C to +80°C	-25°C to +80°C	-25°C to +80°C
LED colour	Yellow	Yellow	Yellow
Approvals/Marks	CE - cULus	CE - cULus	CE - cULus

Inductive proximity sensors, 3-wire, DC

Types M8 Standard - Long body

Connections 2 m cable M8 connector

Flush mountable



Dimensions (mm)	M8 x 46	M8 x 55
Thread (mm)	M8 x 1 x 45	M8 x 1 x 44
Operating frequency	2 kHz	2 kHz
Sensing distance (Sn)	1 mm	1 mm

References

NPN-NO	ICS08L45F01NO	ICS08L45F01NOM5
PNP-NO	ICS08L45F01PO	ICS08L45F01POM5
NPN-NC	ICS08L45F01NC	ICS08L45F01NCM5
PNP-NC	ICS08L45F01PC	ICS08L45F01PCM5

Flush mountable - Extended



Dimensions (mm)	M8 x 49	M8 x 58
Thread (mm)	M8 x 1 x 45	M8 x 1 x 44
Operating frequency	2 kHz	2 kHz
Sensing distance (Sn)	2 mm	2 mm



References



NPN-NO	ICS08L45N02NO	ICS08L45N02NOM5
PNP-NO	ICS08L45N02PO	ICS08L45N02POM5
NPN-NC	ICS08L45N02NC	ICS08L45N02NCM5
PNP-NC	ICS08L45N02PC	ICS08L45N02PCM5

Characteristics

Rated operating voltage	10 - 36 VDC	10 - 36 VDC
Voltage drop	max. 1.6 VDC (@ 200 mA)	max. 1.6 VDC (@ 200 mA)
Degree of protection	IP67	IP67
Protection short-circuit (S)		
Reverse polarity (P)	SPT	SPT
Transients (T)		
Output current	≤ 200 mA @ 50°C; ≤ 150 mA @ 50-80°C	≤ 200 mA @ 50°C; ≤ 150 mA @ 50-80°C
Housing material	Stainless steel	Stainless steel
Operating temperature	-25°C to +80°C	-25°C to +80°C
LED colour	Yellow	Yellow
Approvals/Marks	CE - cULus	CE - cULus

Inductive proximity sensors, 3-wire, DC

Types	M8 Extended - Short body		
Connections	2 m cable	M8 connector	M12 connector
Flush mountable			
Dimensions (mm)	M8 x 31	M8 x 40	M8 x 53.6
Thread (mm)	M8 x 1 x 30	M8 x 1 x 29	M8 x 1 x 29
Operating frequency	2 kHz	2 kHz	2 kHz
Sensing distance (Sn)	2 mm	2 mm	2 mm
References			
NPN-NO	ICS08S30F02NO	ICS08S30F02NOM5	
PNP-NO	ICS08S30F02PO	ICS08S30F02POM5	ICS08S30F02POM1
NPN-NC	ICS08S30F02NC	ICS08S30F02NCM5	
PNP-NC	ICS08S30F02PC	ICS08S30F02PCM5	

Non-flush mountable			
Dimensions (mm)	M8 x 34	M8 x 43	M8 x 56.6
Thread (mm)	M8 x 1 x 30	M8 x 1 x 29	M8 x 1 x 29
Operating frequency	2 kHz	2 kHz	2 kHz
Sensing distance (Sn)	4 mm	4 mm	4 mm
References			
NPN-NO	ICS08S30N04NO	ICS08S30N04NOM5	
PNP-NO	ICS08S30N04PO	ICS08S30N04POM5	ICS08S30N04POM1
NPN-NC	ICS08S30N04NC	ICS08S30N04NCM5	
PNP-NC	ICS08S30N04PC	ICS08S30N04PCM5	

Characteristics flush and non-flush mountable			
Rated operating voltage	10 - 36 VDC	10 - 36 VDC	10 - 36 VDC
Voltage drop	max. 1.6 VDC (@ 200 mA)	max. 1.6 VDC (@ 200 mA)	max. 1.6 VDC (@ 200 mA)
Degree of protection	IP67	IP67	IP67
Protection short-circuit (S) Reverse polarity (P) Transients (T)	SPT	SPT	SPT
Output current	≤ 200 mA @ 50°C; ≤ 150 mA @ 50-80°C	≤ 200 mA @ 50°C; ≤ 150 mA @ 50-80°C	≤ 200 mA @ 50°C; ≤ 150 mA @ 50-80°C
Housing material	Stainless steel	Stainless steel	Stainless steel
Operating temperature	-25°C to +80°C	-25°C to +80°C	-25°C to +80°C
LED colour	Yellow	Yellow	Yellow
Approvals/Marks	CE - cULus	CE - cULus	CE - cULus

Inductive proximity sensors, 3-wire, DC

Types M8 Extended - Long body

Connections 2 m cable M8 connector

Flush mountable



Dimensions (mm)	M8 x 46	M8 x 55
Thread (mm)	M8 x 1 x 45	M8 x 1 x 44
Operating frequency	2 kHz	2 kHz
Sensing distance (Sn)	2 mm	2 mm

References

NPN-NO	ICS08L45F02NO	ICS08L45F02NOM5
PNP-NO	ICS08L45F02PO	ICS08L45F02POM5
NPN-NC	ICS08L45F02NC	ICS08L45F02NCM5
PNP-NC	ICS08L45F02PC	ICS08L45F02PCM5

Non-flush mountable



Dimensions (mm)	M8 x 49	M8 x 58
Thread (mm)	M8 x 1 x 45	M8 x 1 x 44
Operating frequency	2 kHz	2 kHz
Sensing distance (Sn)	4 mm	4 mm





References





NPN-NO	ICS08L45N04NO	ICS08L45N04NOM5
PNP-NO	ICS08L45N04PO	ICS08L45N04POM5
NPN-NC	ICS08L45N04NC	ICS08L45N04NCM5
PNP-NC	ICS08L45N04PC	ICS08L45N04PCM5

Characteristics flush and non-flush mountable

Rated operating voltage	10 - 36 VDC	10 - 36 VDC
Voltage drop	max. 1.6 VDC (@ 200 mA)	max. 1.6 VDC (@ 200 mA)
Degree of protection	IP67	IP67
Protection short-circuit (S)		
Reverse polarity (P)	SPT	SPT
Transients (T)		
Output current	≤ 200 mA @ 50°C; ≤ 150 mA @ 50-80°C	≤ 200 mA @ 50°C; ≤ 150 mA @ 50-80°C
Housing material	Stainless steel	Stainless steel
Operating temperature	-25°C to +80°C	-25°C to +80°C
LED colour	Yellow	Yellow
Approvals/Marks	CE - cULus	CE - cULus

Inductive proximity sensors, 4-wire, DC, extended range

Types	M8 Extended - Short body		M8 Extended - Long body	
Connections	2 m cable	M8 connector	2 m cable	M8 connector
Flush mountable				
Dimensions (mm)	M8 x 31	M8 x 40	M8 x 46	M8 x 55
Thread (mm)	M8 x 1 x 30	M8 x 1 x 29	M8 x 1 x 45	M8 x 1 x 44
Operating frequency	2 kHz	2 kHz	2 kHz	2 kHz
Sensing distance (Sn)	2 mm	2 mm	2 mm	2 mm
References				
NPN-NO+NC	ICS08S30F02NA	ICS08S30F02NAM5	ICS08L45F02NA	ICS08L45F02NAM5
PNP-NO+NC	ICS08S30F02PA	ICS08S30F02PAM5	ICS08L45F02PA	ICS08L45F02PAM5

Non-flush mountable				
Dimensions (mm)	M8 x 34	M8 x 43	M8 x 49	M8 x 58
Thread (mm)	M8 x 1 x 30	M8 x 1 x 29	M8 x 1 x 45	M8 x 1 x 44
Operating frequency	2 kHz	2 kHz	2 kHz	2 kHz
Sensing distance (Sn)	4 mm	4 mm	4 mm	4 mm
References				
NPN-NO+NC	ICS08S30N04NA	ICS08S30N04NAM5	ICS08L45N04NA	ICS08L45N04NAM5
PNP-NO+NC	ICS08S30N04PA	ICS08S30N04PAM5	ICS08L45N04PA	ICS08L45N04PAM5

Characteristics flush and non-flush mountable				
Rated operating voltage	10 - 36 VDC	10 - 36 VDC	10 - 36 VDC	10 - 36 VDC
Voltage drop	≤ 1.6 VDC @ 200 mA	≤ 1.6 VDC @ 200 mA	≤ 1.6 VDC @ 200 mA	≤ 1.6 VDC @ 200 mA
Degree of protection	IP67	IP67	IP67	IP67
Protection short-circuit (S)				
Reverse polarity (P)	SPT	SPT	SPT	SPT
Transients (T)				
Output current	≤ 200 mA @ 50°C ≤ 150 mA @ 50-70°C	≤ 200 mA @ 50°C ≤ 150 mA @ 50-70°C	≤ 200 mA @ 50°C ≤ 150 mA @ 50-70°C	≤ 200 mA @ 50°C ≤ 150 mA @ 50-70°C
Housing material	Stainless steel (AISI304)	Stainless steel (AISI304)	Stainless steel (AISI304)	Stainless steel (AISI304)
Operating temperature	-25°C to +80°C	-25°C to +80°C	-25°C to +80°C	-25°C to +80°C
LED colour	Yellow	Yellow	Yellow	Yellow
Approvals/Marks	CE - cULus	CE - cULus	CE - cULus	CE - cULus

Inductive proximity sensors, 4-wire, DC

Types	M12 Standard - Short body		M12 Standard - Long body	
Connections	2 m cable	M12 connector	2 m cable	M12 connector

Flush mountable



Dimensions (mm)	M12 x 47	M12 x 50	M12 x 67	M12 x 70
Thread (mm)	M12 x 1 x 30	M12 x 1 x 30	M12 x 1 x 50	M12 x 1 x 50
Operating frequency	2 kHz	2 kHz	2 kHz	2 kHz
Sensing distance (Sn)	2 mm	2 mm	2 mm	2 mm

References

NPN-NO+NC	ICB12S30F02NA	ICB12S30F02NAM1	ICB12L50F02NA	ICB12L50F02NAM1
PNP-NO+NC	ICB12S30F02PA	ICB12S30F02PAM1	ICB12L50F02PA	ICB12L50F02PAM1

Non-flush mountable

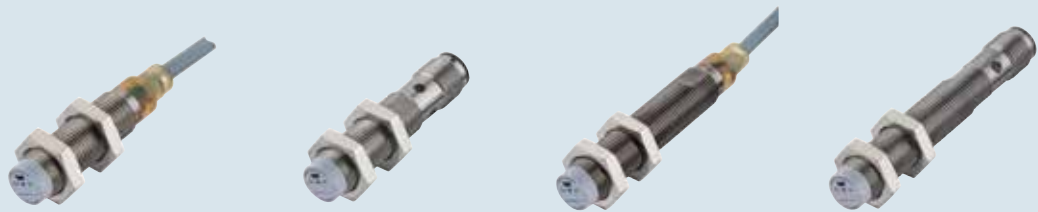

Dimensions (mm)	M12 x 51	M12 x 54	M12 x 71	M12 x 74
Thread (mm)	M12 x 1 x 30	M12 x 1 x 30	M12 x 1 x 50	M12 x 1 x 50
Operating frequency	2 kHz	2 kHz	2 kHz	2 kHz
Sensing distance (Sn)	4 mm	4 mm	4 mm	4 mm





References





NPN-NO+NC	ICB12S30N04NA	ICB12S30N04NAM1	ICB12L50N04NA	ICB12L50N04NAM1
PNP-NO+NC	ICB12S30N04PA	ICB12S30N04PAM1	ICB12L50N04PA	ICB12L50N04PAM1

Characteristics flush and non-flush mountable

Rated operating voltage	10 - 36 VDC	10 - 36 VDC	10 - 36 VDC	10 - 36 VDC
Voltage drop	≤ 2.5 VDC @ 200 mA	≤ 2.5 VDC @ 200 mA	≤ 2.5 VDC @ 200 mA	≤ 2.5 VDC @ 200 mA
Degree of protection	IP67	IP67	IP67	IP67
Protection short-circuit (S)				
Reverse polarity (P)	SPT	SPT	SPT	SPT
Transients (T)				
Output current	< 200 mA @ 50°C ≤ 150 mA @ 50-70°C	< 200 mA @ 50°C ≤ 150 mA @ 50-70°C	< 200 mA @ 50°C ≤ 150 mA @ 50-70°C	< 200 mA @ 50°C ≤ 150 mA @ 50-70°C
Housing material	Nickel-plated brass	Nickel-plated brass	Nickel-plated brass	Nickel-plated brass
Operating temperature	-25°C to +70°C	-25°C to +70°C	-25°C to +70°C	-25°C to +70°C
LED colour	Yellow	Yellow	Yellow	Yellow
Approvals/Marks	CE - cULus	CE - cULus	CE - cULus	CE - cULus





Inductive proximity sensors, 4-wire, DC, extended range





Types	M12 Extended - Short body		M12 Extended - Long body	
Connections	2 m cable	M12 connector	2 m cable	M12 connector
Flush mountable				
Dimensions (mm)	M12 x 47	M12 x 50	M12 x 67	M12 x 70
Thread (mm)	M12 x 1 x 30	M12 x 1 x 30	M12 x 1 x 50	M12 x 1 x 50
Operating frequency	2 kHz	2 kHz	2 kHz	2 kHz
Sensing distance (Sn)	4 mm	4 mm	4 mm	4 mm
References				
NPN-NO+NC	ICB12S30F04NA	ICB12S30F04NAM1	ICB12L50F04NA	ICB12L50F04NAM1
PNP-NO+NC	ICB12S30F04PA	ICB12S30F04PAM1	ICB12L50F04PA	ICB12L50F04PAM1

Non-flush mountable				
Dimensions (mm)	M12 x 51	M12 x 54	M12 x 71	M12 x 74
Thread (mm)	M12 x 1 x 30	M12 x 1 x 30	M12 x 1 x 50	M12 x 1 x 50
Operating frequency	2 kHz	2 kHz	2 kHz	2 kHz
Sensing distance (Sn)	8 mm	8 mm	8 mm	8 mm
References				
NPN-NO+NC	ICB12S30N08NA	ICB12S30N08NAM1	ICB12L50N08NA	ICB12L50N08NAM1
PNP-NO+NC	ICB12S30N08PA	ICB12S30N08PAM1	ICB12L50N08PA	ICB12L50N08PAM1

Characteristics flush and non-flush mountable				
Rated operating voltage	10 - 36 VDC	10 - 36 VDC	10 - 36 VDC	10 - 36 VDC
Voltage drop	≤ 2.5 VDC @ 200 mA	≤ 2.5 VDC @ 200 mA	≤ 2.5 VDC @ 200 mA	≤ 2.5 VDC @ 200 mA
Degree of protection	IP67	IP67	IP67	IP67
Protection short-circuit (S)				
Reverse polarity (P)	SPT	SPT	SPT	SPT
Transients (T)				
Output current	≤ 200 mA @ 50°C ≤ 150 mA @ 50-70°C	≤ 200 mA @ 50°C ≤ 150 mA @ 50-70°C	≤ 200 mA @ 50°C ≤ 150 mA @ 50-70°C	≤ 200 mA @ 50°C ≤ 150 mA @ 50-70°C
Housing material	Nickel-plated brass	Nickel-plated brass	Nickel-plated brass	Nickel-plated brass
Operating temperature	-25°C to +70°C	-25°C to +70°C	-25°C to +70°C	-25°C to +70°C
LED colour	Yellow	Yellow	Yellow	Yellow
Approvals/Marks	CE - cULus	CE - cULus	CE - cULus	CE - cULus

Inductive proximity sensors, 4-wire, DC

Types	M18 Standard - Short body		M18 Standard - Long body	
Connections	2 m cable	M12 connector	2 m cable	M12 connector
Flush mountable				
Dimensions (mm)	M18 x 53	M18 x 54	M18 x 73	M18 x 74
Thread (mm)	M18 x 1 x 30	M18 x 1 x 30	M18 x 1 x 50	M18 x 1 x 50
Operating frequency	1.5 kHz	1.5 kHz	1.5 kHz	1.5 kHz
Sensing distance (Sn)	5 mm	5 mm	5 mm	5 mm
References				
NPN-NO+NC	ICB18S30F05NA	ICB18S30F05NAM1	ICB18L50F05NA	ICB18L50F05NAM1
PNP-NO+NC	ICB18S30F05PA	ICB18S30F05PAM1	ICB18L50F05PA	ICB18L50F05PAM1

Non-flush mountable				
Dimensions (mm)	M18 x 63	M18 x 64	M18 x 83	M18 x 84
Thread (mm)	M18 x 1 x 30	M18 x 1 x 30	M18 x 1 x 50	M18 x 1 x 50
Operating frequency	1.5 kHz	1.5 kHz	1.5 kHz	1.5 kHz
Sensing distance (Sn)	8 mm	8 mm	8 mm	8 mm
References				
NPN-NO+NC	ICB18S30N08NA	ICB18S30N08NAM1	ICB18L50N08NA	ICB18L50N08NAM1
PNP-NO+NC	ICB18S30N08PA	ICB18S30N08PAM1	ICB18L50N08PA	ICB18L50N08PAM1

Characteristics flush and non-flush mountable

Rated operating voltage	10 - 36 VDC	10 - 36 VDC	10 - 36 VDC	10 - 36 VDC
Voltage drop	≤ 2.5 VDC @ 200 mA	≤ 2.5 VDC @ 200 mA	≤ 2.5 VDC @ 200 mA	≤ 2.5 VDC @ 200 mA
Degree of protection	IP67	IP67	IP67	IP67
Protection short-circuit (S)				
Reverse polarity (P)	SPT	SPT	SPT	SPT
Transients (T)				
Output current	≤ 200 mA @ 50°C ≤ 150 mA @ 50-70°C	≤ 200 mA @ 50°C ≤ 150 mA @ 50-70°C	≤ 200 mA @ 50°C ≤ 150 mA @ 50-70°C	≤ 200 mA @ 50°C ≤ 150 mA @ 50-70°C
Housing material	Nickel-plated brass	Nickel-plated brass	Nickel-plated brass	Nickel-plated brass
Operating temperature	-25°C to +70°C	-25°C to +70°C	-25°C to +70°C	-25°C to +70°C
LED colour	Yellow	Yellow	Yellow	Yellow
Approvals/Marks	CE - cULus	CE - cULus	CE - cULus	CE - cULus

Inductive proximity sensors, 4-wire, DC, extended range

Types	M18 Extended - Short body		M18 Extended - Long body	
Connections	2 m cable	M12 connector	2 m cable	M12 connector



Dimensions (mm)	M18 x 53	M18 x 54	M18 x 73	M18 x 74
Thread (mm)	M18 x 1 x 30	M18 x 1 x 30	M18 x 1 x 50	M18 x 1 x 50
Operating frequency	1.5 kHz	1.5 kHz	1.5 kHz	1.5 kHz
Sensing distance (Sn)	8 mm	8 mm	8 mm	8 mm

References

NPN-NO+NC	ICB18S30F08NA	ICB18S30F08NAM1	ICB18L50F08NA	ICB18L50F08NAM1
PNP-NO+NC	ICB18S30F08PA	ICB18S30F08PAM1	ICB18L50F08PA	ICB18L50F08PAM1



Dimensions (mm)	M18 x 63	M18 x 64	M18 x 83	M18 x 84
Thread (mm)	M18 x 1 x 30	M18 x 1 x 30	M18 x 1 x 50	M18 x 1 x 50
Operating frequency	1.5 kHz	1.5 kHz	1.5 kHz	1.5 kHz
Sensing distance (Sn)	14 mm	14 mm	14 mm	14 mm

References

NPN-NO+NC	ICB18S30N14NA	ICB18S30N14NAM1	ICB18L50N14NA	ICB18L50N14NAM1
PNP-NO+NC	ICB18S30N14PA	ICB18S30N14PAM1	ICB18L50N14PA	ICB18L50N14PAM1

Characteristics quasi-flush and non-flush mountable

Rated operating voltage	10 - 36 VDC	10 - 36 VDC	10 - 36 VDC	10 - 36 VDC
Voltage drop	≤ 2.5 VDC @ 200 mA	≤ 2.5 VDC @ 200 mA	≤ 2.5 VDC @ 200 mA	≤ 2.5 VDC @ 200 mA
Degree of protection	IP67	IP67	IP67	IP67
Protection short-circuit (S) Reverse polarity (P) Transients (T)	SPT	SPT	SPT	SPT
Output current	≤ 200 mA @ 50°C ≤ 150 mA @ 50-70°C	≤ 200 mA @ 50°C ≤ 150 mA @ 50-70°C	≤ 200 mA @ 50°C ≤ 150 mA @ 50-70°C	≤ 200 mA @ 50°C ≤ 150 mA @ 50-70°C
Housing material	Nickel-plated brass	Nickel-plated brass	Nickel-plated brass	Nickel-plated brass
Operating temperature	-25°C to +70°C	-25°C to +70°C	-25°C to +70°C	-25°C to +70°C
LED colour	Yellow	Yellow	Yellow	Yellow
Approvals/Marks	CE - cULus	CE - cULus	CE - cULus	CE - cULus

Inductive proximity sensors, 4-wire, DC

Types	M30 Standard - Short body		M30 Standard - Long body	
Connections	2 m cable	M12 connector	2 m cable	M12 connector

Flush mountable



Dimensions (mm)	M30 x 43.6	M30 x 55	M30 x 63.6	M30 x 75
Thread (mm)	M30 x 1.5 x 30	M30 x 1.5 x 30	M30 x 1.5 x 50	M30 x 1.5 x 50
Operating frequency	1 kHz	1 kHz	1 kHz	1 kHz
Sensing distance (Sn)	10 mm	10 mm	10 mm	10 mm

References

NPN-NO+NC	ICB30S30F10NA	ICB30S30F10NAM1	ICB30L50F10NA	ICB30L50F10NAM1
PNP-NO+NC	ICB30S30F10PA	ICB30S30F10PAM1	ICB30L50F10PA	ICB30L50F10PAM1

Non-flush mountable



Dimensions (mm)	M30 x 55.6	M30 x 67	M30 x 75.6	M30 x 87
Thread (mm)	M30 x 1.5 x 30	M30 x 1.5 x 30	M30 x 1.5 x 50	M30 x 1.5 x 50
Operating frequency	1 kHz	1 kHz	1 kHz	1 kHz
Sensing distance (Sn)	15 mm	15 mm	15 mm	15 mm



References





NPN-NO+NC	ICB30S30N15NA	ICB30S30N15NAM1	ICB30L50N15NA	ICB30L50N15NAM1
PNP-NO+NC	ICB30S30N15PA	ICB30S30N15PAM1	ICB30L50N15PA	ICB30L50N15PAM1

Characteristics flush and non-flush mountable

Rated operating voltage	10 - 36 VDC	10 - 36 VDC	10 - 36 VDC	10 - 36 VDC
Voltage drop	≤ 2.5 VDC @ 200 mA	≤ 2.5 VDC @ 200 mA	≤ 2.5 VDC @ 200 mA	≤ 2.5 VDC @ 200 mA
Degree of protection	IP67	IP67	IP67	IP67
Protection short-circuit (S)				
Reverse polarity (P)	SPT	SPT	SPT	SPT
Transients (T)				
Output current	≤ 200 mA @ 50°C ≤ 150 mA @ 50-70°C	≤ 200 mA @ 50°C ≤ 150 mA @ 50-70°C	≤ 200 mA @ 50°C ≤ 150 mA @ 50-70°C	≤ 200 mA @ 50°C ≤ 150 mA @ 50-70°C
Housing material	Nickel-plated brass	Nickel-plated brass	Nickel-plated brass	Nickel-plated brass
Operating temperature	-25°C to +70°C	-40°C to +70°C	-25°C to +70°C	-40°C to +70°C
LED colour	Yellow	Yellow	Yellow	Yellow
Approvals/Marks	CE - cULus	CE - cULus	CE - cULus	CE - cULus









Inductive proximity sensors, 4-wire, DC, extended range

Types	M30 Extended - Short body		M30 Extended - Long body	
Connections	2 m cable	M12 connector	2 m cable	M12 connector
Flush mountable				
Dimensions (mm)	M30 x 43.6	M30 x 55	M30 x 63.6	M30 x 75
Thread (mm)	M30 x 1.5 x 30	M30 x 1.5 x 30	M30 x 1.5 x 50	M30 x 1.5 x 50
Operating frequency	1 kHz	1 kHz	1 kHz	1 kHz
Sensing distance (Sn)	15 mm	15 mm	15 mm	15 mm
References				
NPN-NO+NC	ICB30S30F15NA	ICB30S30F15NAM1	ICB30L50F15NA	ICB30L50F15NAM1
PNP-NO+NC	ICB30S30F15PA	ICB30S30F15PAM1	ICB30L50F15PA	ICB30L50F15PAM1





Non-flush mountable				
Dimensions (mm)	M30 x 55.6	M30 x 67	M30 x 75.6	M30 x 87
Thread (mm)	M30 x 1.5 x 30	M30 x 1.5 x 30	M30 x 1.5 x 50	M30 x 1.5 x 50
Operating frequency	1 kHz	1 kHz	1 kHz	1 kHz
Sensing distance (Sn)	22 mm	22 mm	22 mm	22 mm
References				
NPN-NO+NC	ICB30S30N22NA	ICB30S30N22NAM1	ICB30L50N22NA	ICB30L50N22NAM1
PNP-NO+NC	ICB30S30N22PA	ICB30S30N22PAM1	ICB30L50N22PA	ICB30L50N22PAM1

Characteristics flush and non-flush mountable				
Rated operating voltage	10 - 36 VDC	10 - 36 VDC	10 - 36 VDC	10 - 36 VDC
Voltage drop	≤ 2.5 VDC @ 200 mA	≤ 2.5 VDC @ 200 mA	≤ 2.5 VDC @ 200 mA	≤ 2.5 VDC @ 200 mA
Degree of protection	IP67	IP67	IP67	IP67
Protection short-circuit (S)				
Reverse polarity (P)	SPT	SPT	SPT	SPT
Transients (T)				
Output current	≤ 200 mA @ 50°C ≤ 150 mA @ 50-70°C	≤ 200 mA @ 50°C ≤ 150 mA @ 50-70°C	≤ 200 mA @ 50°C ≤ 150 mA @ 50-70°C	≤ 200 mA @ 50°C ≤ 150 mA @ 50-70°C
Housing material	Nickel-plated brass	Nickel-plated brass	Nickel-plated brass	Nickel-plated brass
Operating temperature	-25°C to +70°C	-40°C to +70°C	-25°C to +70°C	-40°C to +70°C
LED colour	Yellow	Yellow	Yellow	Yellow
Approvals/Marks	CE - cULus	CE - cULus	CE - cULus	CE - cULus



Inductive proximity sensors, NAMUR, DC



Types	M12		M18	
Housing	Steel	Plastic	Steel	Plastic
Flush mountable				
Dimensions short body (mm)	Cable: M12 x 41 Plug (M12): M12 x 54.5	Cable: M12 x 41 Plug (M12): M12 x 54.5	Cable: M18 x 41.6 Plug (M12): M18 x 55	Cable: M18 x 41.6 Plug (M12): M18 x 55
Dimensions long body (mm)	Cable: M12 x 61 Plug (M12): M12 x 74.5	Cable: M12 x 61 Plug (M12): M12 x 74.5	Cable: M18 x 61.6 Plug (M12): M18 x 75	Cable: M18 x 61.6 Plug (M12): M18 x 75
Thread (mm)	Short: M12 x 1 x 30 Long: M12 x 1 x 50	Short: M12 x 1 x 30 Long: M12 x 1 x 50	Short: M18 x 1 x 30 Long: M18 x 1 x 50	Short: M18 x 1 x 30 Long: M18 x 1 x 50
Operating frequency	1.4 kHz	1.4 kHz	500 Hz	500 Hz
Sensing distance (Sn)	2 mm	2 mm	5 mm	5 mm
References				
Short body cable	IA12ESF02UC	IA12CSF02UC	IA18ESF05UC	IA18CSF05UC
Long body cable	IA12ELF02UC	IA12CLF02UC	IA18ELF05UC	IA18CLF05UC
Short body plug	IA12ESF02UCM1	IA12CSF02UCM1	IA18ESF05UCM1	IA18CSF05UCM1
Long body plug	IA12ELF02UCM1	IA12CLF02UCM1	IA18ELF05UCM1	IA18CLF05UCM1
Non-flush mountable				
Dimensions short body (mm)	Cable: M12 x 45 Plug (M12): M12 x 58.5	Cable: M12 x 45 Plug (M12): M12 x 58.5	Cable: M18 x 49.6 Plug (M12): M18 x 63	Cable: M18 x 49.6 Plug (M12): M18 x 63
Dimensions long body (mm)	Cable: M12 x 65 Plug (M12): M12 x 78.5	Cable: M12 x 65 Plug (M12): M12 x 78.5	Cable: M18 x 69.6 Plug (M12): M18 x 83	Short: M18 x 1 x 30 Long: M18 x 1 x 50
Thread (mm)	Short: M12 x 1 x 30 Long: M12 x 1 x 50	Short: M12 x 1 x 30 Long: M12 x 1 x 50	Short: M18 x 1 x 30 Long: M18 x 1 x 50	Short: M18 x 1 x 30 Long: M18 x 1 x 50
Operating frequency	1.2 kHz	1.2 kHz	200 Hz	200 Hz
Sensing distance (Sn)	4 mm	4 mm	8 mm	8 mm
References				
Short body cable	IA12ESN04UC	IA12CSN04UC	IA18ESN08UC	IA18CSN08UC
Long body cable	IA12ELN04UC	IA12CLN04UC	IA18ELN08UC	IA18CLN08UC
Short body plug	IA12ESN04UCM1	IA12CSN04UCM1	IA18ESN08UCM1	IA18CSN08UCM1
Long body plug	IA12ELN04UCM1	IA12CLN04UCM1	IA18ELN08UCM1	IA18CLN08UCM1
Characteristics flush and non-flush mountable				
Rated operating voltage	7 - 9 VDC	7 - 9 VDC	7 - 9 VDC	7 - 9 VDC
Degree of protection	IP67	IP67	IP67	IP67
Housing material	Stainless steel	Thermoplastic polyester	Stainless steel	Thermoplastic polyester
Operating temperature	-25°C to +70°C	-25°C to +70°C	-25°C to +70°C	-25°C to +70°C
LED colour	Yellow	Yellow	Yellow	Yellow
Approvals/Marks	CE - UL - CSA	CE - UL - CSA	CE - UL - CSA	CE - UL - CSA

Inductive proximity sensors, NAMUR, DC

Types	M30	
Housing	Steel	Plastic
Flush mountable		
Dimensions short body (mm)	Cable: M30 x 43.6 Plug (M12): M30 x 55.5	Cable: M30 x 43.6 Plug (M12): M30 x 55.5
Dimensions long body (mm)	Cable: M30 x 63.6 Plug (M12): M30 x 75.5	Cable: M30 x 63.6 Plug (M12): M30 x 75.5
Thread (mm)	Short: M30 x 1.5 x 30 Long: M30 x 1.5 x 50	Short: M30 x 1.5 x 30 Long: M30 x 1.5 x 50
Operating frequency	300 Hz	300 Hz
Sensing distance (Sn)	10 mm	10 mm
References		
Short body cable	IA30ESF10UC	IA30CSF10UC
Long body cable	IA30ELF10UC	IA30CLF10UC
Short body plug	IA30ESF10UCM1	IA30CSF10UCM1
Long body plug	IA30ELF10UCM1	IA30CLF10UCM1
Non-flush mountable		
Dimensions short body (mm)	Cable: M30 x 55.6 Plug (M12): M30 x 67.5	Cable: M30 x 55.6 Plug (M12): M30 x 67.5
Dimensions long body (mm)	Cable: M30 x 75.6 Plug (M12): M30 x 87.5	Cable: M30 x 75.6 Plug (M12): M30 x 87.5
Thread (mm)	Short: M30 x 1.5 x 30 Long: M30 x 1.5 x 50	Short: M30 x 1.5 x 30 Long: M30 x 1.5 x 50
Operating frequency	100 Hz	100 Hz
Sensing distance (Sn)	15 mm	15 mm
References		
Short body cable	IA30ESN15UC	IA30CSN15UC
Long body cable	IA30ELN15UC	IA30CLN15UC
Short body plug	IA30ESN15UCM1	IA30CSN15UCM1
Long body plug	IA30ELN15UCM1	IA30CLN15UCM1
Characteristics flush and non-flush mountable		
Rated operating voltage	7 - 9 VDC	7 - 9 VDC
Degree of protection	IP67	IP67
Housing material	Stainless steel	Thermoplastic polyester
Operating temperature	-25°C to +70°C	-25°C to +70°C
LED colour	Yellow	Yellow
Approvals/Marks	CE - UL - CSA	CE - UL - CSA

Inductive proximity sensors, 2-wire, DC, extended range





Types	M8 Extended - Short body		M12 Extended - Short body	
Connections	2 m cable		2 m cable	M12 connector
Flush mountable				
Dimensions (mm)	M8 x 30		M12 x 49	M12 x 63
Thread (mm)	M8 x 1 x 30		M12 x 1 x 38	M12 x 1 x 38
Operating frequency	2 kHz		1 kHz	1 kHz
Sensing distance (Sn)	2 mm		4 mm	4 mm
References				
NO	IA08BSF02DO		IA12DSF04DO	IA12ASF04DOM1
NC	IA08BSF02DC		IA12DSF04DC	IA12ASF04DCM1





Non-flush mountable				
Dimensions (mm)	M8 x 30		M12 x 53	M12 x 67
Thread (mm)	M8 x 1 x 26		M12 x 1 x 38	M12 x 1 x 38
Operating frequency	2 kHz		800 Hz	800 Hz
Sensing distance (Sn)	4 mm		8 mm	8 mm
References				
NO	IA08BSN04DO		IA12DSN08DO	IA12ASN08DOM1
NC	IA08BSN04DC		IA12DSN08DC	IA12ASN08DCM1

Characteristics flush and non-flush mountable

Rated operating voltage	10 - 30 VDC	10 - 40 VDC	10 - 40 VDC
Voltage drop	≤ 8 VDC @ max. load	≤ 3 VDC @ max. load	≤ 3 VDC @ max. load
Degree of protection	IP67	IP67	IP67
Protection short-circuit (S)			
Reverse polarity (P)	SPT	SPT	SPT
Transients (T)			
Output current	3 - 100 mA	5 - 100 mA	5 - 100 mA
Housing material	Stainless steel	Nickel-plated brass	Nickel-plated brass
Operating temperature	-25°C to +70°C	-25°C to +70°C	-25°C to +70°C
LED colour	Yellow	Yellow	Yellow
Approvals/Marks	CE - CSA	CE - UL - CSA	CE - UL - CSA

Inductive proximity sensors, 2-wire, DC, extended range

Types	M18 Extended - Short body		M30 Extended - Short body	
Connections	2 m cable	M12 connector	2 m cable	M12 connector
Flush mountable				
Dimensions (mm)	M18 x 42	M18 x 55	M30 x 44	M30 x 55
Thread (mm)	M18 x 1 x 30	M18 x 1 x 30	M30 x 1.5 x 30	M30 x 1.5 x 30
Operating frequency	500 Hz	500 Hz	400 Hz	400 Hz
Sensing distance (Sn)	8 mm	8 mm	15 mm	15 mm
References				
NO	IA18DSF08DO	IA18ASF08DOM1	IA30DSF15DO	IA30ASF15DOM1
NC	IA18DSF08DC	IA18ASF08DCM1	IA30DSF15DC	IA30ASF15DCM1

Non-flush mountable				
Dimensions (mm)	M18 x 50	M18 x 63	M30 x 56	M30 x 67
Thread (mm)	M18 x 1 x 30	M18 x 1 x 30	M30 x 1.5 x 30	M30 x 1.5 x 30
Operating frequency	400 Hz	400 Hz	200 Hz	200 Hz
Sensing distance (Sn)	14 mm	14 mm	22 mm	22 mm
References				
NO	IA18DSN14DO	IA18ASN14DOM1	IA30DSN22DO	IA30ASN22DOM1
NC	IA18DSN14DC	IA18ASN14DCM1	IA30DSN22DC	IA30ASN22DCM1

Characteristics flush and non-flush mountable				
Rated operating voltage	10 - 40 VDC	10 - 40 VDC	10 - 40 VDC	10 - 40 VDC
Voltage drop	≤ 3 VDC @ max. load	≤ 3 VDC @ max. load	≤ 3 VDC @ max. load	≤ 3 VDC @ max. load
Degree of protection	IP67	IP67	IP67	IP67
Protection short-circuit (S)				
Reverse polarity (P)	SPT	SPT	SPT	SPT
Transients (T)				
Output current	5 - 100 mA	5 - 100 mA	5 - 100 mA	5 - 100 mA
Housing material	Nickel-plated brass	Nickel-plated brass	Nickel-plated brass	Nickel-plated brass
Operating temperature	-25°C to +70°C	-25°C to +70°C	-25°C to +70°C	-25°C to +70°C
LED colour	Yellow	Yellow	Yellow	Yellow
Approvals/Marks	CE - UL - CSA	CE - UL - CSA	CE - UL - CSA	CE - UL - CSA

Inductive proximity sensors, 2-wire, AC

Types

M12 Standard - Long body

Connections

2 m cable

M12 connector

Flush mountable



Dimensions (mm)

M12 x 66

M12 x 74.5

Thread (mm)

M12 x 1 x 50

M12 x 1 x 50

Operating frequency

25 Hz

25 Hz

Sensing distance (Sn)

2 mm

2 mm

References

SCR-NO

EI1202TBOSL

EI1202TBOSL-6

SCR-NC

EI1202TBCSL

Non-flush mountable



Dimensions (mm)

M12 x 70

M12 x 78.5

Thread (mm)

M12 x 1 x 50

M12 x 1 x 50

Operating frequency

25 Hz

25 Hz

Sensing distance (Sn)

4 mm

4 mm

References

SCR-NO

EI1204TBOSL

EI1204TBOSL-6

SCR-NC

EI1204TBCSL

Characteristics flush and non-flush mountable

Rated operating voltage

20 - 265 VAC

20 - 265 VAC

Voltage drop

≤ 8 VAC

≤ 8 VAC

Degree of protection

IP67

IP67

Protection short-circuit (S)

Reverse polarity (P)

Transients (T)

T

T

Output current

< 500 mA

< 500 mA

Housing material

Stainless steel

Stainless steel

Operating temperature

-25°C to +70°C

-25°C to +70°C

LED colour

Yellow





Yellow





Approvals/Marks

CE - UL - CSA

CE - UL - CSA

Inductive proximity sensors, 2-wire, AC

Types	M18 Standard - Short body		M18 Standard - Long body	
Connections	2 m cable	M12 connector	2 m cable	M12 connector
Flush mountable				
Dimensions (mm)	M18 x 57	M18 x 55	M18 x 77	M18 x 75
Thread (mm)	M18 x 1 x 30	M18 x 1 x 30	M18 x 1 x 50	M18 x 1 x 50
Operating frequency	25 Hz	25 Hz	25 Hz	25 Hz
Sensing distance (Sn)	5 mm	5 mm	5 mm	5 mm
References				
SCR-NO	EI1805TBOSS	EI1805TBOSS-6	EI1805TBOSL	EI1805TBOSL-6
SCR-NC	EI1805TBCSS		EI1805TBCSL	

Non-flush mountable				
Dimensions (mm)	M18 x 65	M18 x 63	M18 x 85	M18 x 83
Thread (mm)	M18 x 1 x 30	M18 x 1 x 30	M18 x 1 x 50	M18 x 1 x 50
Operating frequency	25 Hz	25 Hz	25 Hz	25 Hz
Sensing distance (Sn)	8 mm	8 mm	8 mm	8 mm
References				
SCR-NO	EI1808TBOSS	EI1808TBOSS-6	EI1808TBOSL	EI1808TBOSL-6
SCR-NC	EI1808TBCSS		EI1808TBCSL	EI1808TBCSL-6

Characteristics flush and non-flush mountable				
Rated operating voltage	20 - 265 VAC	20 - 265 VAC	20 - 265 VAC	20 - 265 VAC
Voltage drop	≤ 8 VAC	≤ 8 VAC	≤ 8 VAC	≤ 8 VAC
Degree of protection	IP67	IP67	IP67	IP67
Protection short-circuit (S)				
Reverse polarity (P)	T	T	T	T
Transients (T)				
Output current	< 500 mA	< 500 mA	< 500 mA	< 500 mA
Housing material	Stainless steel	Stainless steel	Stainless steel	Stainless steel
Operating temperature	-25°C to +70°C	-25°C to +70°C	-25°C to +70°C	-25°C to +70°C
LED colour	Yellow	Yellow	Yellow	Yellow
Approvals/Marks	CE - UL - CSA	CE - UL - CSA	CE - UL - CSA	CE - UL - CSA

Inductive proximity sensors, 2-wire, AC

Types	M30 Standard - Short body		M30 Standard - Long body	
Connections	2 m cable	M12 connector	2 m cable	M12 connector

Flush mountable



Dimensions (mm)	M30 x 59		M30 x 79	M30 x 75.5
Thread (mm)	M30 x 1.5 x 30		M30 x 1.5 x 50	M30 x 1.5 x 50
Operating frequency	25 Hz		25 Hz	25 Hz
Sensing distance (Sn)	10 mm		10 mm	10 mm

References

SCR-NO	EI3010TBOSS		EI3010TBOSL	EI3010TBOSL-6
SCR-NC	EI3010TBCSS		EI3010TBCSL	

Non-flush mountable



Dimensions (mm)	M30 x 87.5	M30 x 67.5	M30 x 91	M30 x 71
Thread (mm)	M30 x 1.5 x 30	M30 x 1.5 x 30	M30 x 1.5 x 50	M30 x 1.5 x 50
Operating frequency	25 Hz	25 Hz	25 Hz	25 Hz
Sensing distance (Sn)	15 mm	15 mm	15 mm	15 mm



References



SCR-NO	EI3015TBOSS	EI3015TBOSS-6	EI3015TBOSL	EI3015TBOSL-6
SCR-NC	EI3015TBCSS		EI3015TBCSL	

Characteristics flush and non-flush mountable

Rated operating voltage	20 - 265 VAC	20 - 265 VAC	20 - 265 VAC	20 - 265 VAC
Voltage drop	≤ 8 VAC	≤ 8 VAC	≤ 8 VAC	≤ 8 VAC
Degree of protection	IP67	IP67	IP67	IP67
Protection short-circuit (S)				
Reverse polarity (P)	T	T	T	T
Transients (T)				
Output current	< 500 mA	< 500 mA	< 500 mA	< 500 mA
Housing material	Stainless steel	Stainless steel	Stainless steel	Stainless steel
Operating temperature	-25°C to +70°C	-25°C to +70°C	-25°C to +70°C	-25°C to +70°C
LED colour	Yellow	Yellow	Yellow	Yellow
Approvals/Marks	CE - UL - CSA	CE - UL - CSA	CE - UL - CSA	CE - UL - CSA

Inductive proximity sensors, 2-wire, AC

Types	M18 Standard Short body	M18 Standard - Long body		M30 Standard Long body
Connections	2 m cable	2 m cable	M12 connector	2 m cable
Flush mountable				
Dimensions (mm)	M18 x 57	M18 x 77		M30 x 79
Thread (mm)	M18 x 1 x 30	M18 x 1 x 50		M30 x 1.5 x 50
Operating frequency	25 Hz	25 Hz		25 Hz
Sensing distance (Sn)	5 mm	5 mm		10 mm
References				
SCR-NO	EI1805TBOPS	EI1805TBOPL		EI3010TBOPL

Non-flush mountable				
Dimensions (mm)		M18 x 85	M18 x 83	M30 x 91
Thread (mm)		M18 x 1 x 50	M18 x 1 x 50	M30 x 1.5 x 50
Operating frequency		25 Hz	25 Hz	25 Hz
Sensing distance (Sn)		8 mm	8 mm	15 mm
References				
SCR-NO		EI1808TBOPL		EI3015TBOPL
SCR-NC		EI1808TBCPL	EI1808TBCPL-6	

Characteristics flush and non-flush mountable				
Rated operating voltage	20 - 265 VAC	20 - 265 VAC	20 - 265 VAC	20 - 265 VAC
Voltage drop	≤ 8 VAC	≤ 8 VAC	≤ 8 VAC	≤ 8 VAC
Degree of protection	IP67	IP67	IP67	IP67
Protection short-circuit (S)				
Reverse polarity (P)	T	T	T	T
Transients (T)				
Output current	< 500 mA	< 500 mA	< 500 mA	< 500 mA
Housing material	Thermoplastic polyester	Thermoplastic polyester	Thermoplastic polyester	Thermoplastic polyester
Operating temperature	-25°C to +70°C	-25°C to +70°C	-25°C to +70°C	-25°C to +70°C
LED colour	Yellow	Yellow	Yellow	Yellow
Approvals/Marks	CE - UL - CSA	CE - UL - CSA	CE - UL - CSA	CE - UL - CSA

Inductive proximity sensors, micro switch 2-wire DC

Types Micro switch

Connections 2 m cable



Dimensions body (mm) 30 x 19 x 15

Thread (mm) Ø 12 x 16

Sensing distance (Sn) 1 kHz

Output 4 mm

References

NO IG12FSF04DO

NC IG12FSF04DC

Specifications

Rated operating voltage 10 to 40 VDC

Voltage drop ≤ 3 VDC at max. load

Degree of protection IP67

Protection short-circuit (S)
Reverse polarity (P)
Transients (T) SPT



Output current ≤ 5 - 100 mA

Housing material Anodized aluminium





Operating temperature -25°C to +70°C

Approvals/Marks CE

Inductive proximity sensors, switch, polyester housing

Types	Transistor NPN/PNP		Power MOSFET output AC/DC	
Connections	Terminals		Terminals	Terminals
Non-flush mountable				
Dimensions (mm)	40 x 40 x 118		40 x 40 x 118	40 x 40 x 118
Operating frequency	≤ 100 Hz		≤ 25 Hz AC; 40 Hz DC	≤ 25 Hz
Sensing distance (Sn)	30 mm		30 mm	30 mm
References				
NPN - NO / NC	IC40CNN30NAT1			
PNP - NO / NC	IC40CNN30PAT1			
AC / DC - NO			IC40CNN30COT1	
AC / DC - NC			IC40CNN30CCT1	
AC - NO / NC				IC40CNN30TAT1
Specifications				
Rated operating voltage	10 - 30 VDC		20 - 250 VAC/DC	20 - 250 VAC
Degree of protection	IP67		IP67	IP67
Protection short-circuit (S) Reverse polarity (P) Transients (T)	SP		S	
Output current	≤ 200 mA		5 - 200 mA @ 25°C	5 - 200 mA @ 25°C
Housing material	Thermoplastic polyester		Thermoplastic polyester	Thermoplastic polyester
Operating temperature	-25°C to +70°C		-25°C to +70°C	-25°C to +70°C
LED colour	Red, Green		Red, Green	Red, Green
Approvals/Marks	CE		CE	CE

Inductive proximity sensors, loop detector

Types	Single loop	Dual loop	Single loop	Dual loop
Connections	Plug 11 pin circular	Plug 11 pin circular	DIN rail	DIN rail
				
Dimensions HxWxD (mm)	81 x 35.5 x 60.2	81 x 35.5 x 60.2	84 x 22 x 99	84 x 22 x 99
Adjustment	Auto	Auto	Auto	Auto
Adjustable sensitivity via potentiometer	0.01% to 1.00%	0.01% to 1.00%	0.01% to 1.00%	0.01% to 1.00%
Loop inductance	20-1000 µH	20-1000 µH	20-1000 µH	20-1000 µH
Input	1 Loop	2 Loop	1 Loop	2 Loop
Output	2 x SPDT, relay output	2 x SPDT, relay output	2 x SPDT, relay output	2 x SPDT, relay output
References				
24-240 VAC/VDC	LDP1PA2DU24	LDP2PA2DU24	LDD1PA2DU24	LDD2PA2DU24
Main features				
Automatic sensitivity boost (ASB)	Yes	Yes	Yes	Yes
Automatic loop frequency tuning	Yes	Yes	Yes	Yes
4 adjustable loop frequency channels	Yes	Yes	Yes	Yes
Selectable fail safe / fail secure mode	Yes	Yes	Yes	Yes
Multicolor LED for easy setup and advanced diagnostics	Yes	Yes	Yes	Yes
Directional logic	No	Yes	No	Yes
Specifications				
Operating temperature	-40°C to +70°C	-40°C to +70°C	-40°C to +70°C	-40°C to +70°C
Degree of protection	IP30	IP30	IP20	IP20
Mounting	11 pin circular plug	11 pin circular plug	DIN rail	DIN rail
Approvals/Marks	CE - UL - CSA	CE - UL - CSA	CE - cULus	CE - cULus

Ultrasonic sensors, 1 x digital output - Short body

Types	UA18CSD..TI	UA18CSD..M1TI	UA18ESD..TI	UA18ESD..M1TI
Connections	2 m cable	M12 connector	2 m cable	M12 connector
				
Dimensions (mm)	M18 x 53	M18 x 60	M18 x 53	M18 x 60
References				
Sensing distance (Sn)	40 - 300 mm	40 - 300 mm	40 - 300 mm	40 - 300 mm
Operating frequency	≤ 8 Hz	≤ 8 Hz	≤ 8 Hz	≤ 8 Hz
Blind zone	≤ 40 mm	≤ 40 mm	≤ 40 mm	≤ 40 mm
1 x NPN	UA18CSD03NPTI	UA18CSD03NPM1TI	UA18ESD03NPTI	UA18ESD03NPM1TI
1 x PNP	UA18CSD03PPTI	UA18CSD03PPM1TI	UA18ESD03PPTI	UA18ESD03PPM1TI
Sensing distance (Sn)	80 - 800 mm	80 - 800 mm	80 - 800 mm	80 - 800 mm
Operating frequency	≤ 5 Hz	≤ 5 Hz	≤ 5 Hz	≤ 5 Hz
Blind zone	≤ 80 mm	≤ 80 mm	≤ 80 mm	≤ 80 mm
1 x NPN	UA18CSD08NPTI	UA18CSD08NPM1TI	UA18ESD08NPTI	UA18ESD08NPM1TI
1 x PNP	UA18CSD08PPTI	UA18CSD08PPM1TI	UA18ESD08PPTI	UA18ESD08PPM1TI
Specifications				
Rated operating voltage	10 - 30 VDC	10 - 30 VDC	10 - 30 VDC	10 - 30 VDC
Voltage drop	≤ 2.2 VDC	≤ 2.2 VDC	≤ 2.2 VDC	≤ 2.2 VDC
Degree of protection	IP67	IP67	IP67	IP67
Protection short-circuit (S) Reverse polarity (P) Transients (T)	SPT	SPT	SPT	SPT
Load current	< 100 mA	< 100 mA	< 100 mA	< 100 mA
Housing material	PBT	PBT	Stainless steel AISI 316L	Stainless steel AISI 316L
Operating temperature	-20°C to +60°C	-20°C to +60°C	-20°C to +60°C	-20°C to +60°C
LED colour	Yellow (output), Green (Echo ON)	Yellow (output), Green (Echo ON)	Yellow (output), Green (Echo ON)	Yellow (output), Green (Echo ON)
Approvals/Marks	CE - cULus	CE - cULus	CE - cULus	CE - cULus



Ultrasonic sensors, analogue output - Short body

Types	UA18CSD..TI	UA18CSD..M1TI	UA18ESD..TI	UA18ESD..M1TI
Connections	2 m cable	M12 connector	2 m cable	M12 connector
				
Dimensions (mm)	M18 x 53	M18 x 60	M18 x 53	M18 x 60
References				
Sensing distance (Sn)	40 - 300 mm	40 - 300 mm	40 - 300 mm	40 - 300 mm
Response time	≤ 400 mS	≤ 400 mS	≤ 400 mS	≤ 400 mS
Blind zone	≤ 40 mm	≤ 40 mm	≤ 40 mm	≤ 40 mm
4-20 mA	UA18CSD03AGTI	UA18CSD03AGM1TI	UA18ESD03AGTI	UA18ESD03AGM1TI
0-10 V	UA18CSD03AKTI	UA18CSD03AKM1TI	UA18ESD03AKTI	UA18ESD03AKM1TI
Sensing distance (Sn)	80 - 800 mm	80 - 800 mm	80 - 800 mm	80 - 800 mm
Response time	≤ 400 mS	≤ 400 mS	≤ 400 mS	≤ 400 mS
Blind zone	≤ 80 mm	≤ 80 mm	≤ 80 mm	≤ 80 mm
4-20 mA	UA18CSD08AGTI	UA18CSD08AGM1TI	UA18ESD08AGTI	UA18ESD08AGM1TI
0-10 V	UA18CSD08AKTI	UA18CSD08AKM1TI	UA18ESD08AKTI	UA18ESD08AKM1TI
Specifications				
Rated operating voltage NG or PG NK or PK	10 - 30 VDC	10 - 30 VDC	10 - 30 VDC	10 - 30 VDC
Degree of protection	IP67	IP67	IP67	IP67
Protection short-circuit (S) Reverse polarity (P) Transients (T)	Supply: PT Analogue output: P	Supply: PT Analogue output: P	Supply: PT Analogue output: P	Supply: PT Analogue output: P
Housing material	PBT	PBT	Stainless steel AISI 316L	Stainless steel AISI 316L
Operating temperature	-20°C to +60°C	-20°C to +60°C	-20°C to +60°C	-20°C to +60°C
LED colour	Yellow (output), Green (Echo ON)	Yellow (output), Green (Echo ON)	Yellow (output), Green (Echo ON)	Yellow (output), Green (Echo ON)
Approvals/Marks	CE - cULus	CE - cULus	CE - cULus	CE - cULus

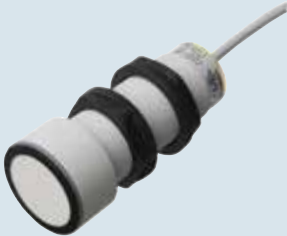

Ultrasonic sensors, 2 x digital outputs

Types	UA18CAD..TI	UA18CAD..M1TI	UA30CAD35..TI	UA30CAD35..M1TI
Connections	2 m cable	M12 connector	2 m cable	M12 connector
				
Dimensions (mm)	M18 x 85	M18 x 85	M30 x 90	M30 x 90
References				
Sensing distance (Sn)	50 - 400 mm	50 - 400 mm	250 - 3500 mm	250 - 3500 mm
Operating frequency	≤ 10 Hz	≤ 10 Hz	≤ 2 Hz	≤ 2 Hz
Blind zone	≤ 50 mm	≤ 50 mm	≤ 250 mm	≤ 250 mm
2 x NPN	UA18CAD04NPTI	UA18CAD04NPM1TI	UA30CAD35NPTI	UA30CAD35NPM1TI
2 x PNP	UA18CAD04PPTI	UA18CAD04PPM1TI	UA30CAD35PPTI	UA30CAD35PPM1TI
Sensing distance (Sn)	100 - 900 mm	100 - 900 mm		
Operating frequency	≤ 4 Hz	≤ 4 Hz		
Blind zone	≤ 100 mm	≤ 100 mm		
2 x NPN	UA18CAD09NPTI	UA18CAD09NPM1TI		
2 x PNP	UA18CAD09PPTI	UA18CAD09PPM1TI		
Sensing distance (Sn)	200 - 2200 mm	200 - 2200 mm		
Operating frequency	≤ 1 Hz	≤ 1 Hz		
Blind zone	≤ 200 mm	≤ 200 mm		
2 x NPN	UA18CAD22NPTI	UA18CAD22NPM1TI		
2 x PNP	UA18CAD22PPTI	UA18CAD22PPM1TI		
Specifications				
Rated operating voltage	15 - 30 VDC	15 - 30 VDC	12 - 30 VDC	12 - 30 VDC
Voltage drop	≤ 2.2 VDC	≤ 2.2 VDC	≤ 2.2 VDC	≤ 2.2 VDC
Degree of protection	IP67	IP67	IP67	IP67
Protection short-circuit (S) Reverse polarity (P) Transients (T)	SPT	SPT	SPT	SPT
Load current	< 500 mA	< 500 mA	< 300 mA	< 300 mA
Load current - UL	< 100 mA	< 100 mA	< 100 mA	< 100 mA
Housing material	PBT	PBT	PBT	PBT
Operating temperature	-20°C to +60°C	-20°C to +60°C	-20°C to +70°C	-20°C to +70°C
LED colour	Yellow	Yellow	Yellow, Green	Yellow, Green
Approvals/Marks	CE - cULus	CE - cULus	CE - cULus	CE - cULus

Ultrasonic sensors, 2 x digital outputs

Types	UA30CAD60..TI	UA30CAD60..M1TI
Connections	2 m cable	M12 connector
		
Dimensions (mm)	M30 (Ø40) x 90	M30 (Ø40) x 90
References		
Sensing distance (Sn)	350 - 6000 mm	350 - 6000 mm
Operating frequency	≤ 1 Hz	≤ 1 Hz
Blind zone	≤ 350 mm	≤ 350 mm
2 x NPN	UA30CAD60NPTI	UA30CAD60NPM1TI
2 x PNP	UA30CAD60PPTI	UA30CAD60PPM1TI
Specifications		
Rated operating voltage	12 - 30 VDC	12 - 30 VDC
Voltage drop	≤ 2.2 VDC	≤ 2.2 VDC
Degree of protection	IP67	IP67
Protection short-circuit (S) Reverse polarity (P) Transients (T)	SPT	SPT
Load current	< 300 mA	< 300 mA
Load current - UL	< 100 mA	< 100 mA
Housing material	PBT	PBT
Operating temperature	-20°C to +70°C	-20°C to +70°C
LED colour	Yellow, Green	Yellow, Green
Approvals/Marks	CE - cULus	CE - cULus



Ultrasonic sensors, 2 x digital outputs

Types	UA18EAD..TI	UA18EAD..M1TI	UA30EAD35..TI	UA30EAD35..M1TI
Connections	2 m cable	M12 connector	2 m cable	M12 connector
				
Dimensions (mm)	M18 x 85	M18 x 85	M30 x 90	M30 x 90
References				
Sensing distance (Sn)	50 - 400 mm	50 - 400 mm	350 - 3500 mm	350 - 3500 mm
Operating frequency	≤ 10 Hz	≤ 10 Hz	≤ 2 Hz	≤ 2 Hz
Blind zone	≤ 50 mm	≤ 50 mm	≤ 350 mm	≤ 350 mm
2 x NPN	UA18EAD04NPTI	UA18EAD04NPM1TI	UA30EAD35NPTI	UA30EAD35NPM1TI
2 x PNP	UA18EAD04PPTI	UA18EAD04PPM1TI	UA30EAD35PPTI	UA30EAD35PPM1TI
Sensing distance (Sn)	100 - 900 mm	100 - 900 mm		
Operating frequency	≤ 4 Hz	≤ 4 Hz		
Blind zone	≤ 100 mm	≤ 100 mm		
2 x NPN	UA18EAD09NPTI	UA18EAD09NPM1TI		
2 x PNP	UA18EAD09PPTI	UA18EAD09PPM1TI		
Sensing distance (Sn)	200 - 1500 mm	200 - 1500 mm		
Operating frequency	≤ 1 Hz	≤ 1 Hz		
Blind zone	≤ 200 mm	≤ 200 mm		
2 x NPN	UA18EAD15NPTI	UA18EAD15NPM1TI		
2 x PNP	UA18EAD15PPTI	UA18EAD15PPM1TI		
Specifications				
Rated operating voltage	15 - 30 VDC	15 - 30 VDC	12 - 30 VDC	12 - 30 VDC
Voltage drop	≤ 2.2 VDC	≤ 2.2 VDC	≤ 2.2 VDC	≤ 2.2 VDC
Degree of protection	IP67	IP67	IP67	IP67
Protection short-circuit (S) Reverse polarity (P) Transients (T)	SPT	SPT	SPT	SPT
Load current	< 500 mA	< 500 mA	< 300 mA	< 300 mA
Load current - UL	< 100 mA	< 100 mA	< 100 mA	< 100 mA
Housing material	AISI 316L	AISI 316L	AISI 316L	AISI 316L
Operating temperature	-20°C to +60°C	-20°C to +60°C	-20°C to +70°C	-20°C to +70°C
LED colour	Yellow	Yellow	Yellow, Green	Yellow, Green
Approvals/Marks	CE - cULus	CE - cULus	CE - cULus	CE - cULus

Ultrasonic sensors, analogue and digital output

Types	UA18CAD..TI	UA18CAD..M1TI	UA30CAD35..TI	UA30CAD35..M1TI
Connections	2 m cable	M12 connector	2 m cable	M12 connector
				
Dimensions (mm)	M18 x 85	M18 x 85	M30 x 90	M30 x 90
References				
Sensing distance (Sn)	50 - 400 mm	50 - 400 mm	250 - 3500 mm	250 - 3500 mm
Operating frequency	≤ 10 Hz	≤ 10 Hz	≤ 2 Hz	≤ 2 Hz
Blind zone	≤ 50 mm	≤ 50 mm	≤ 250 mm	≤ 250 mm
NPN, 4-20 mA	UA18CAD04NGTI	UA18CAD04NGM1TI	UA30CAD35NGTI	UA30CAD35NGM1TI
PNP, 4-20 mA	UA18CAD04PGTI	UA18CAD04PGM1TI	UA30CAD35PGTI	UA30CAD35PGM1TI
NPN, 0-10 V	UA18CAD04NKTI	UA18CAD04NKM1TI	UA30CAD35NKTI	UA30CAD35NKM1TI
PNP, 0-10 V	UA18CAD04PKTI	UA18CAD04PKM1TI	UA30CAD35PKTI	UA30CAD35PKM1TI
Sensing distance (Sn)	100 - 900 mm	100 - 900 mm		
Operating frequency	≤ 4 Hz	≤ 4 Hz		
Blind zone	≤ 100 mm	≤ 100 mm		
NPN, 4-20 mA	UA18CAD09NGTI	UA18CAD09NGM1TI		
PNP, 4-20 mA	UA18CAD09PGTI	UA18CAD09PGM1TI		
NPN, 0-10 V	UA18CAD09NKTI	UA18CAD09NKM1TI		
PNP, 0-10 V	UA18CAD09PKTI	UA18CAD09PKM1TI		
Sensing distance (Sn)	200 - 2200 mm	200 - 2200 mm		
Operating frequency	≤ 1 Hz	≤ 1 Hz		
Blind zone	≤ 200 mm	≤ 200 mm		
NPN, 4-20 mA	UA18CAD22NGTI	UA18CAD22NGM1TI		
PNP, 4-20 mA	UA18CAD22PGTI	UA18CAD22PGM1TI		
NPN, 0-10 V	UA18CAD22NKTI	UA18CAD22NKM1TI		
PNP, 0-10 V	UA18CAD22PKTI	UA18CAD22PKM1TI		
Specifications				
Rated operating voltage NG or PG NK or PK	15 - 30 VDC 15 - 30 VDC	15 - 30 VDC 15 - 30 VDC	12 - 30 VDC 15 - 30 VDC	12 - 30 VDC 15 - 30 VDC
Voltage drop	≤ 2.2 VDC	≤ 2.2 VDC	≤ 2.2 VDC	≤ 2.2 VDC
Degree of protection	IP67	IP67	IP67	IP67
Protection short-circuit (S) Reverse polarity (P) Transients (T)	Digital output: SPT Supply: PT Analogue output: P	Digital output: SPT Supply: PT Analogue output: P	Digital output: SPT Supply: PT Analogue output: P	Digital output: SPT Supply: PT Analogue output: P
Load current	< 500 mA	< 500 mA	< 100 mA	< 100 mA
Load current - UL	< 100 mA	< 100 mA	< 100 mA	< 100 mA
Housing material	PBT	PBT	PBT	PBT
Operating temperature	-20°C to +60°C	-20°C to +60°C	-20°C to +70°C	-20°C to +70°C
LED colour	Yellow	Yellow	Yellow, Green	Yellow, Green
Approvals/Marks	CE - cULus	CE - cULus	CE - cULus	CE - cULus

Ultrasonic sensors, analogue and digital output

Types	UA30CAD60..TI	UA30CAD60..M1TI
Connections	2 m cable	M12 connector
		
Dimensions (mm)	M30 (Ø40) x 90	M30 (Ø40) x 90
References		
Sensing distance (Sn)	350 - 6000 mm	350 - 6000 mm
Operating frequency	≤ 1 Hz	≤ 1 Hz
Blind zone	≤ 350 mm	≤ 350 mm
NPN, 4-20 mA	UA30CAD60NGTI	UA30CAD60NGM1TI
PNP, 4-20 mA	UA30CAD60PGTI	UA30CAD60PGM1TI
NPN, 0-10 V	UA30CAD60NKTI	UA30CAD60NKM1TI
PNP, 0-10 V	UA30CAD60PKTI	UA30CAD60PKM1TI
Specifications		
Rated operating voltage NG or PG NK or PK	12 - 30 VDC 15 - 30 VDC	12 - 30 VDC 15 - 30 VDC
Voltage drop	≤ 2.2 VDC	≤ 2.2 VDC
Degree of protection	IP67	IP67
Protection short-circuit (S) Reverse polarity (P) Transients (T)	Digital output: SPT Supply: PT Analogue output: P	Digital output: SPT Supply: PT Analogue output: P
Load current	< 100 mA	< 100 mA
Load current - UL	< 100 mA	< 100 mA
Housing material	PBT	PBT
Operating temperature	-20°C to +70°C	-20°C to +70°C
LED colour	Yellow, Green	Yellow, Green
Approvals/Marks	CE - cULus	CE - cULus

Ultrasonic sensors, analogue and digital output

Types	UA18EAD..TI	UA18EAD..M1TI	UA30EAD35..TI	UA30EAD35..M1TI
Connections	2 m cable	M12 connector	2 m cable	M12 connector
				
Dimensions (mm)	M18 x 85	M18 x 85	M30 x 93	M30 x 100
References				
Sensing distance (Sn)	50 - 400 mm	50 - 400 mm	350 - 3500 mm	350 - 3500 mm
Operating frequency	≤ 10 Hz	≤ 10 Hz	≤ 2 Hz	≤ 2 Hz
Blind zone	≤ 50 mm	≤ 50 mm	≤ 350 mm	≤ 350 mm
NPN, 4-20 mA	UA18EAD04NGTI	UA18EAD04NGM1TI	UA30EAD35NGTI	UA30EAD35NGM1TI
PNP, 4-20 mA	UA18EAD04PGTI	UA18EAD04PGM1TI	UA30EAD35PGTI	UA30EAD35PGM1TI
NPN, 0-10 V	UA18EAD04NKTI	UA18EAD04NKM1TI	UA30EAD35NKTI	UA30EAD35NKM1TI
PNP, 0-10 V	UA18EAD04PKTI	UA18EAD04PKM1TI	UA30EAD35PKTI	UA30EAD35PKM1TI
Sensing distance (Sn)	100 - 900 mm	100 - 900 mm		
Operating frequency	≤ 4 Hz	≤ 4 Hz		
Blind zone	≤ 100 mm	≤ 100 mm		
NPN, 4-20 mA	UA18EAD09NGTI	UA18EAD09NGM1TI		
PNP, 4-20 mA	UA18EAD09PGTI	UA18EAD09PGM1TI		
NPN, 0-10 V	UA18EAD09NKTI	UA18EAD09NKM1TI		
PNP, 0-10 V	UA18EAD09PKTI	UA18EAD09PKM1TI		
Sensing distance (Sn)	200 - 1500 mm	200 - 1500 mm		
Operating frequency	≤ 1 Hz	≤ 1 Hz		
Blind zone	≤ 200 mm	≤ 200 mm		
NPN, 4-20 mA	UA18EAD15NGTI	UA18EAD15NGM1TI		
PNP, 4-20 mA	UA18EAD15PGTI	UA18EAD15PGM1TI		
NPN, 0-10 V	UA18EAD15NKTI	UA18EAD15NKM1TI		
PNP, 0-10 V	UA18EAD15PKTI	UA18EAD15PKM1TI		
Specifications				
Rated operating voltage NG or PG NK or PK	15 - 30 VDC 15 - 30 VDC	15 - 30 VDC 15 - 30 VDC	12 - 30 VDC 15 - 30 VDC	12 - 30 VDC 15 - 30 VDC
Voltage drop	≤ 2.2 VDC	≤ 2.2 VDC	≤ 2.2 VDC	≤ 2.2 VDC
Degree of protection	IP67	IP67	IP67	IP67
Protection short-circuit (S) Reverse polarity (P) Transients (T)	Digital output: SPT Supply: PT Analogue output: P	Digital output: SPT Supply: PT Analogue output: P	Digital output: SPT Supply: PT Analogue output: P	Digital output: SPT Supply: PT Analogue output: P
Load current	< 100 mA	< 100 mA	< 100 mA	< 100 mA
Load current - UL	< 100 mA	< 100 mA	< 100 mA	< 100 mA
Housing material	AISI 316L	AISI 316L	AISI 316L	AISI 316L
Operating temperature	-20°C to +60°C	-20°C to +60°C	-20°C to +70°C	-20°C to +70°C
LED colour	Yellow	Yellow	Yellow, Green	Yellow, Green
Approvals/Marks	CE - cULus	CE - cULus	CE - cULus	CE - cULus

Ultrasonic sensors, DC, analogue, remote teach

	Programmable RS232	Integrated amplifier
Types	UA30CLD..M7	UA12BLD..M1TR
Connections	M16 connector	M12 connector



Dimensions (mm)	M30 x 136	M12 x 79
-----------------	-----------	----------

Diffuse reflective references

Operating frequency	5 - 30 Hz programmable	20 Hz
Sensing distance (Sn)	150 - 1500 mm adj.	25 - 200 mm adj.
0-10 VDC	UA30CLD15FKM7	
4-20 mA	UA30CLD15FGM7	
NPN-NO/NC		UA12BLD02NPM1TR
PNP-NO/NC		UA12BLD02PPM1TR
Sensing distance (Sn)	250 - 2000 mm adj.	
0-10 VDC	UA30CLD20FKM7	
4-20 mA	UA30CLD20FGM7	
Sensing distance (Sn)	350 - 3500 mm adj.	
0-10 VDC	UA30CLD35FKM7	
4-20 mA	UA30CLD35FGM7	

Specifications

Rated operating voltage	19 - 30 VDC	10 - 30 VDC
Voltage drop	≤ 2.5 VDC	≤ 4.5 V
Degree of protection	IP67	IP65
Protection short-circuit (S)		
Reverse polarity (P)	SPT	SPT
Transients (T)		
Load current	< 100 mA Analogue see type	< 100 mA
Housing material	PBTB	Stainless steel
Operating temperature	-15°C to +70°C	-20°C to +70°C
LED colour	Yellow + Green	
Remarks	Hold/sync. input RS232	
Approvals/Marks	CE - UL - cUL	CE

Adapters

Types	AUA - RT
Connections	M12 connector







Dimensions (mm)	17 x 56
-----------------	---------





Specifications

Programming adapter for remote teach sensors ending with "RT"

Conductive level sensors

Types	VN / VNI		VNY / VNYI		VPC		VPP	
Connections	Cable (PVC) 2 m		Screw connection		Screw connection		Screw connection	
								
Electrodes								
Number of electrodes	1, 2, 3 or 4		1, 2, 3 or 4		1, 2 or 3		1, 2 or 3	
Diameter/length (mm)	D5/1000		D5/1000		D4/500		D4/500	
Material	Stainless steel		Stainless steel		Stainless steel		Stainless steel	
Isolation of electrodes	Yes (VNI)		Yes (VNYI)		Yes		Yes	
Isolation	Polyethylene		Polyethylene		Polyethylene		PVDF	
Housing								
Pipe thread	1½"		1½"		½" [VPC x05] or 1" [VPC x10]		½" [VPC x05] or 1" [VPC x10]	
Material	Nylon 6		Nylon 6		PVC		Polypropylene	
References								
1 electrode	VN1	VNI1	VNY1	VNYI1	VPC105	VPC110	VPP105	VPP110
2 electrodes	VN2	VNI2	VNY2	VNYI2	VPC205	VPC210	VPP205	VPP210
3 electrodes	VN3	VNI3	VNY3	VNYI3	VPC310		VPP310	
4 electrodes	VN4	VNI4	VNY4	VNYI4				
Specifications								
Degree of protection	IP67		IP67		IP67		IP67	
Operating temperature	0°C to +90°C		0°C to +90°C		0°C to +60°C		0°C to +100°C	
Approvals/Marks	CE		CE		CE		CE	

Conductive level sensors

Types	VT / VTI	CLH	VH	A 94-10
Connections	Cable (Silicone)	Screw connection	Cable (Neoprene)	Cable (PVC)
				

Electrodes				
Number of electrodes	1, 2, 3 or 4	2 or 4 + reference	1 (hanging)	2 (hanging)
Diameter/length (mm)	D5/1000	D4	D18/36.5 or D32/75.5	D22/75.0
Material	Stainless steel	Stainless steel	Stainless steel	Stainless steel
Isolation of electrodes	Yes [VTI]	Yes	No [VH1, VH3, VH4] - Yes [VH2]	No
Isolation	Teflon	Kynar, Polyolefin	Nylon 6	

Housing				
Pipe thread	1½"	1½"		
Material	Teflon	Polypropylene	Nylon 6 [VH1, VH2] Polycarbonate [VH3, VH4]	Polyester





References				
1 electrode	VT1	VTI1		
1 electrode with Neoprene cable			VH1 or VH2	
1 electrode with UV resistant PVC cable			VH3	
1 electrode without cable			VH4	
2 electrodes	VT2	VTI2		A 94-10
3 electrodes	VT3	VTI3	CLH3*	
4 electrodes	VT4	VTI4		
5 electrodes			CLH5*	

Specifications				
Degree of protection	IP67	IP65	IP67	IP67
Operating temperature	0°C to +145°C	-20°C to +90°C	0°C to +90°C	0°C to +60°C
Approvals/Marks	CE	CE	CE	CE

Electrodes (Stainless steel ANSI316)				
No Insulation				
1 m			CLE1	
2 m			CLE2	
Extension 1 m			CLE1X	
Kynar (DVP) insulation				
1 m			CLE1K	
2 m			CLE2K	
Extension 1 m			CLE1KX	
Polyolefin insulation				
1 m			CLE1P	
2 m			CLE2P	
Extension 1 m			CLE1PX	





* Electrodes shall be ordered separately

Conductive level sensors



Level controller				
Types	CLD1	CLD2	CLP2 Basic	CLP2
Connections	DIN-rail	DIN-rail	Plug 11 pin circular	Plug 11 pin circular
				
Function	Filling or emptying. Selectable by rotary switches. Conductive liquids	Filling or emptying. Selectable by rotary switches. Conductive liquids	Filling or emptying. Selectable by rotary switches. Conductive liquids	Filling or emptying. Selectable by rotary switches. Conductive liquids
Adjustable	Yes, Potentiometer	Yes, Potentiometer	Yes, Potentiometer	Yes, Potentiometer
Sensitivity	5 K Ω to 150 K Ω	250 Ω to 500 K Ω	5 K Ω to 150 K Ω	250 Ω to 500 K Ω
Functions switch	- Timer 1 to 30 sec. delay on filling or/and emptying	- Filling / Emptying - 3-levels: Low, Standard and High	- Filling / Emptying	- Filling / Emptying - 3-levels: Low, Standard and High
Input	1 + reference	2 + reference	2 + reference	2 + reference
Output	8 A / 250 VAC SPST	8 A / 250 VAC SPDT	8 A / 250 VAC SPDT	8 A / 250 VAC DPDT
Power Supply	24 VAC/DC	24 - 240 VAC/DC	24 VDC, 24 VAC, 115 VAC or 230 VAC	24 VAC/DC, 115 VAC or 230 VAC
References				
24 240 VAC/DC		CLD2EB1BU24		
24 VDC			CLP2EB1B724	
24 VAC			CLP2EB1B024	
24 VAC/DC	CLD1EA1CM24			CLP2EA1CM24
115 VAC			CLP2EB1B115	CLP2EA1C115
230 VAC			CLP2EB1B230	CLP2EA1C230
Specifications				
Time delay	< 300 mS	< 2S	< 2S	< 300 mS
Housing material	ABS VO	PA66	NORYL PPO	NORYL PPO
Operating temperature	-20°C to +50°C	-20°C to +50°C	-20°C to +50°C	-20°C to +50°C
Output LED colour	Yellow	Yellow	Yellow	Yellow
Power LED colour	Green	Green	Green	Green
Approvals/Marks	CE - cURus - CSA	CE - cULus	CE - cURus - CSA	CE - cURus - CSA

Conductive level sensors

Level controller

Types	CLD2	CLP2 Master-Slave	CLD4	CLP4
Connections	DIN-rail	Plug 11 pin circular	DIN-rail	Plug 11 pin circular
				
Function	Filling or emptying. Selectable by rotary switches. Conductive liquids	Filling or emptying. Selectable by rotary switches. Conductive liquids Master - Slave system	Filling, emptying or combinations. Selectable by rotary switches. Conductive liquids	Filling, emptying or combinations. Selectable by rotary switches. Conductive liquids
Adjustable	Yes, Potentiometer	Yes, Potentiometer	Yes, Potentiometer	Yes, Potentiometer
Sensitivity	250 Ω to 500 KΩ	250 Ω to 500 KΩ	250 Ω to 500 KΩ	250 Ω to 500 KΩ
Functions switch	- Filling / Emptying - 3-levels: Low, Standard and High	- Filling / Emptying - 3-levels: Low, Standard and High	- Tank - well - Direct in to out 2 probe - Low and High alarm - 2 system in one, filling and/or emptying - 3-levels: Low, Standard and High	- Tank - well - Direct in to out 2 probe - Low and High alarm - 2 system in one, filling and/or emptying - 3-levels: Low, Standard and High
Input	2 + reference	2 + reference	2 to 4 + reference	2 to 4 + reference
Output	8 A / 250 VAC DPDT	8 A / 250 VAC SPDT	8 A / 250 VAC SPDT, SPST	8 A / 250 VAC 2 X SPST
Power Supply	24 VAC/DC, 115 VAC or 230 VAC	24 VAC/DC, 115 VAC or 230 VAC	24 VAC/DC, 115 VAC or 230 VAC	24 VAC/DC, 115 VAC or 230 VAC
References				
24 VAC/DC	CLD2EA1CM24	CLP2FA1BM24	CLD4MA2DM24	CLP4MA2AM24
115 VAC	CLD2EA1C115	CLP2FA1B115	CLD4MA2D115	CLP4MA2A115
230 VAC	CLD2EA1C230	CLP2FA1B230	CLD4MA2D230	CLP4MA2A230
Specifications				
Time delay	< 300 mS	< 300 mS	< 300 mS	< 300 mS
Housing material	ABS VO	NORYL PPO	ABS VO	NORYL PPO
Operating temperature	-20°C to +50°C	-20°C to +50°C	-20°C to +50°C	-20°C to +50°C
Output LED colour	Yellow	Yellow	Yellow	Yellow
Power LED colour	Green	Green	Green	Green
Approvals/Marks	CE - cURus - CSA	CE - cURus - CSA	CE - cURus - CSA	CE - cURus - CSA

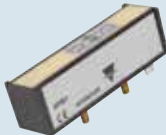
Proximity magnetic sensors, rectangular

Rectangular			
Types	S series	SPB2 series	SPA1 series
			
Dimensions (mm)	11.5 x 79 x 21.2	25.5 x 85 x 24	16 x 90 x 20
Electrical specifications			
Max. switch. voltage contact	250 VAC [SA / SC 2, SB2 / -S5] 1500 VAC [SA / SC 8] 230 VAC [SS2, S.BS.2]	250 VAC	24 VDC [output 1 and 2]
Max. switch. current contact	1 A [SS2, S.BS.2] 3 A [SA2, SC2, SB2, SB2S5, SA8, SC8]	3 A	0.5 A [output 1] 4 A [output 2]
Max. switch. power contact	100 VA [SA / SC 2, SB2 / -S5] 120 VA [SA / SC 8] 60 VA [SS2, S.BS.2]	100 VA	5 VA [output 1] 100 VA [output 2]
Power supply			24 VDC
General specifications			
Operating distance	5 - 32 mm	5 - 30 mm	12 mm
Output connection	PVC cable, 0.5 m (0.24 m Type S5)	Faston [SPB2] 2 m PVC Cable [SPB22MT]	PVC cable, 19 cm Pig-tail
Degree of protection	IP67	IP67 [SPB22MT] IP65 [SPB2]	IP67
Operating temperature	-25°C to +75°C	-25°C to +75°C	-25°C to +80°C
Housing material	Plastic	Plastic	ABS class V0
References			
Normally open	SA2 SA8		
Normally closed	SC2 SC8		
Change - Over	SS2		
Bistable	SB2 SB2S5	SPB2 SPB22MT	
Bistable CO	S.BS.2		
Normally closed, 2 outputs			SPA1S2 SPA1S3

Proximity magnetic sensors, rectangular

Rectangular

Types	M and MS series	MM series
		

Dimensions (mm)	8.3 x 37 x 16	6.1 x 23.5 x 14 [A6] 7 x 27 x 11 [A3, S1]
-----------------	---------------	--

Electrical specifications

Max. switch. voltage contact	100 VAC [MS1] 230 VAC [MSA1] 500 VAC [MA3, MC3]	100 VAC [S1, A6] 500 VAC [A3]
Max. switch. current contact	0.25 A [MS1] 0.5 A [MA3, MC3] 0.75 A [MSA1]	0.25 A [S1] 0.5 A [A3, A6]
Max. switch. power contact	5 VA [MS1] 10 VA [MSA1, MA3, MC3]	5 VA [S1] 10 VA [A3, A6]

General specifications



Operating distance	7 - 35 mm	10 - 40 mm
Output connection	PVC cable, 0.5 m (2 m, Type MSA1)	PVC cable [A3, S1] Twin lead cable [A6]
Degree of protection	IP67	IP67
Operating temperature	-25°C to +75°C	-25°C to +75°C
Housing material	Plastic	Plastic

References

Normally open	MSA1 MA3	MMA3 MMA6
Normally closed	MC3	
Change - Over	MS1	MMS1

Proximity magnetic sensors, cylindrical

Cylindrical

Types	FM... series	FMM... series	FMMP... series
			

Dimensions (mm)	Ø 9.3 [A3, C3, S1] M10 x 0.75 [A3S5, A6] M12 x 1 [C3S1, A9S1]	M8 x 1	Ø 6 x 25 [L25] Ø 6 x 33 [L33] Ø 6 x 38 [L38]
-----------------	---	--------	--

Electrical specifications

Max. switch. voltage contact	100 VAC [S1, A6] 230 VAC [A9S1] 500 VAC [A3, C3, A3S5, C3S1]	100 VAC [A6, S1] 500 VAC [A3]	140 VAC
Max. switch. current contact	0.25 A [S1] 0.5 A [A3, C3, A6, A3S5, C3S1] 3 A [A9S1]	0.25 A [S1] 0.5 A [A3, A6]	1 A
Max. switch. power contact	5 VA [A3, C3, A3S5, C3S1] 60 VA [A9S1] 100 VA [S1, A6]	5 VA [S1] 10 VA [A3, A6]	10 VA
Max carry current			1.2 A

General specifications

Operating distance	5 - 36 mm	8 - 27 mm	> 8 mm
Output connection	PVC cable 0.5 m for Ø 9.3 2 m for M10 and M12	PVC cable, 2 m	Twin lead cable, 0.5 m
Degree of protection	IP67	IP67	IP67
Operating temperature	-25°C to +75°C	-25°C to +70°C	-20°C to +75°C
Housing material	Plastic [A3, C3, S1] Nickel plated brass [A6] Brass [A3S5, C3S1, A9S1]	Stainless steel [A3, S1] Nickel plated brass [A6]	Plastic

References

Normally open	FMA3 FMA3S5 FMA6 FMA9S1	FMMA3 FMMA6	FMMPA7L25
Normally closed	FMC3 FMC3S1		
Change - Over	FMS1	FMMS1	

Proximity magnetic sensors, cylindrical

Cylindrical			
Types	FMP... series	FS... series	FSM... series
			

Dimensions (mm)	M12 x 1 x 100	Ø 13.5 [A2, A8, C2, C8, S2] M10 x 1.25 [A2S3, S2S1] M12 x 1 [A2S4, S2S4] M16 x 1.5 [B2]	M12 x 1 [A2, A7, S2] M16 x 1 [S2S2AT]
-----------------	---------------	--	--

Electrical specifications

Max. switch. voltage contact	120 VAC/DC [C7] 175 VDC, 120 VAC [S1] 200 VDC, 140 VAC [A7] 230 VAC/DC [A9, C9, A9S1] 250 VAC/DC [B2]	230 VAC [S2, S2S1, S2S4] 250 VAC [A2, B2, C2, A2S3, A2S4] 1500 VAC [A8, C8]	24 VDC [A7] 230 VAC [S2, S2S2AT] 250 VAC [A2]
Max. switch. current contact	0.25 A [S1] 0.5 A [C7] 1 A [A7] 3 A [B2, A9, C9, A9S1]	1 A [S2, S2S4, S2S1] 3 A [A2, B2, C2, A8, C8, A2S3, A2S4]	0.5 A [S2S2AT] 1 A [S2] 3 A [A2] 50 mA [A7]
Max. switch. power contact	5 VA [S1] 10 VA [A7, C7] 60 VA [A9, C9, A9S1] 120 VA [B2]	60 VA [S2S1, S2S4, S2] 100 VA [A2, B2, C2, A2S3, A2S4] 120 VA [A8, C8]	30 VA [S2S2AT] 60 VA [S2] 100 VA [A2] (A7 negligible)





General specifications

Operating distance	7 - 26 mm	3 - 32 mm	2 - 19 mm
Output connection	PVC cable, 2 m	PVC cable, 2 m 0.5 m for Ø 13.5	Silicone cable, 2 m [A7] Silicone cable, 0.5 m [S2S2AT] PVC cable, 2 m [A2, S2]
Degree of protection	IP67	IP67	IP67
Operating temperature	-25°C to +75°C	-25°C to +75°C	-25°C to +75°C [A2, A7, S2] -20°C to +150°C [S2S2AT]
Housing material	Plastic	Plastic [A2, A8, C2, C8, S2, B2] Brass [A2S3 / S4, S2S1 / S4]	Brass [S2S2, S2S2AT] Nickel plated brass [A2, A7, S2]



References

Normally open	FMPA7 [black] FMPA9 [black] FMPA9S1 [black]	FSA2 FSA8 FSA2S32MT FSA2S42MT	FSMA2 FSMA7
Normally closed	FMPC7 [red] FMPC9 [red]	FSC2 FSC8	
Change - Over	FMPS1 [blue]	FSS2 FSS2S12MT FSS2S42MT	FSMS2 FSMS2S2AT
Bistable	FMPB2 [grey]	FSB22MT	

Proximity magnetic sensors, slot

			Slot	
Types	ISY series		IM series	
				
Dimensions (mm)	10 x 45 x 37		7 x 28 x 18.5	
Electrical specifications				
Max. switch. voltage contact	100 VAC [S1] 500 VAC [C3]		100 VAC [S1] 500 VAC [C3]	
Max. switch. current contact	0.25 A [S1] 0.5 A [C3]		0.25 A [S1] 0.5 A [C3]	
Max. switch. power contact	5 VA [S1] 10 VA [C3]		5 VA [S1] 10 VA [C3]	
General specifications				
Output connection	PVC cable, 0.5 m		PVC cable, 0.5 m	
Degree of protection	IP67		IP67	
Operating temperature	-25°C to +75°C		-25°C to +75°C	
Housing materials	Plastic		Plastic	
References				
Normally closed	ISYC3		IMC3	
Change - Over	ISYS1		IMS1	
Types	Magnetic units CL series			
Shapes	Rectangular	Trapezoidal		Cylindrical
				
General specifications				
Minimum separation:	Dimensions (mm)	References		
10	25 x 14 x 8	CL1		
20	44.5 x 12 x 9	CL2		
30	59 x 18 x 9	CL3		
50	76 x 25 x 18	CL4		
Not mandatory		Dimensions (mm)	References	Dimensions (mm) References
		90 x 31 x 22.5	CL90	Ø 9.3 x 32 CL10
				Ø 13.5 x 65 CL11
				Ø 18 x 6 CL18
				Ø 23 x 9 CL23
				Ø 31 x 10 CL31
				Ø 20 x 10 CL20S1
				Ø 22.1 x 11.3 CL20S3

Level magnetic sensors

Cylindrical			
Types	ILM series	ILMM series	ILMP series
			

Float Diameter (mm)	Ø 53	Ø 28	Ø 25
---------------------	------	------	------



Output functions			
	Normally open, Normally closed [2, 8] Change-over [S2]	Normally open and normally closed [5, 590, 5ATS1] Normally open [5S1] Normally closed [5S2, 5S2AT]	Normally open, normally closed

Electrical specifications			
Max. switch. voltage contact	230 VAC [S2] - 250 VAC [2] 1500 VAC [8]	240 VAC, 220 VDC	240 VAC, 200 VDC
Max. switch. current contact	1 A [S2] 3 A [2, 8]	0.5 A	0.5 A
Max. switch. power contact	60 VA [S2] - 100 VA [2] 120 VA [8]	50 VA	50 VA



General specifications			
Output connection	Silicone cable, 0.5 m	XLPE cable, 0.3 m 1,1 m [ATS1]	PVC cable, 0.3 m
Min. liquid specific gravity	0.75 kg / dm ³	0.75 kg / dm ³	
Max. pressure	20 kg / cm ²	10 kg / cm ²	2 kg / cm ²
Degree of protection	IP67	IP67	IP67
Operating temperature	-25°C to +120°C [2, 8, S2]	-10°C to +120°C [5, 590] -10°C to +200°C [5ATS1, 5S2AT] -20°C to +120°C [5S1, 5S2]	-20°C to +80°C
Housing materials	AISI 316 stainless steel	"AISI 304 stainless steel [5, 590 5ATS1] AISI316 stainless steel [5S2AT, 5S1, 5S2]"	Plastic

References			
Normally open / Normally closed	ILM.2 ILM8	ILMM5 ILMM590 ILMM5ATS1	ILMP5 ILMP5P
Change - Over	ILMS2		
Normally closed		ILMM5S2AT ILMM5S2	
Normally open		ILMM5S1	

Level magnetic sensors

Cylindrical			
Types	ILMPU - ILU - ILMU series	ILSP series	FLM series - Flux Sensors
			
Float Diameter (mm)	Ø 17.5 [ILMPU] Ø 31 [ILMU] Ø 45 [ILU]	Ø 44	Ø 20
Electrical specifications			
Max. switch. voltage contact	240 VAC, 230 VAC [ILUS2], 200 VDC [ILMPU5, ILMU5], 250 VAC [ILU2], 1000 VAC [ILU8]	230 VAC [S2], 250 VAC [2], 1500 VAC [8]	100 VAC
Max. switch. current contact	0.5 A [ILMP, ILM], 1 A [ILUS2], 3 A [ILU2, ILU8]	1 A [S2], 3 A [2, 8]	0.4 A
Max. switch. power contact	50 VA [ILMP, ILM], 60 VA [ILUS2], 100 VA [ILU2], 120 VA [ILU8]	60 VA [S2], 100 VA [2], 120 VA [8]	10 VA
General specifications			
Output connection	XLPE cable, 0.3 m [ILMPU5], PVC cable, 0.3 m [ILMU5], Silicone cable, 0.5 m [ILU2, ILU8, ILUS2]	Silicone cable, 0.5 m	HT105 PVC cable ended with 6.35 mm female faston
Operating distance D_{on}			+5 mm
Release distance D_{off}			$D_{on} - 2$ mm
Min. liquid specific gravity	0.70 kg / dm ³ [ILMPU, ILMU], 0.75 kg / dm ³ [ILU]	0.75 kg / dm ³	
Max. pressure	2 kg / cm ² [ILMPU, ILMU], 100 kg / cm ² [ILU]	0.6 kg / cm ²	
Degree of protection	IP68	IP67	IP67
Operating temperature	-20°C to +80°C [ILMPU, ILMU], -25°C to +100°C [ILU]	-25°C to +100 °C	-30°C to +105°C
Housing materials	Non toxic polypropylene or plastic	Plastic	Stainless steel
References			
Normally open / Normally closed	ILMPU5 ILMU5	ILSP2 ILSP8	
Normally open	ILU2 ILU8		FLMA1S1
Change - Over	ILUS2	ILSPS2	

Safety magnetic sensors

Safety magnetic sensors			
Types	MC 88C... Left exit		
Connections	2 m cable	M8 connector	M12 pig-tail
			
Dimensions (mm)	88 x 25 x 13	88 x 25 x 13	88 x 25 x 13
Operating frequency	100 Hz	100 Hz	100 Hz
Assured switching distance (Sao)	5 mm (with MC88CM1) 8 mm (with MC88CM2) 18 mm (with MC88CM3)	5 mm (with MC88CM1) 8 mm (with MC88CM2) 18 mm (with MC88CM3)	5 mm (with MC88CM1) 8 mm (with MC88CM2) 18 mm (with MC88CM3)
Assured switch-off distance (Sar)	15 mm (with MC88CM1) 18 mm (with MC88CM2) 30 mm (with MC88CM3)	15 mm (with MC88CM1) 18 mm (with MC88CM2) 30 mm (with MC88CM3)	15 mm (with MC88CM1) 18 mm (with MC88CM2) 30 mm (with MC88CM3)
Electrical specifications			
Rated operating voltage	12-24 VAC/DC	12-24 VAC/DC	12-24 VAC/DC
Rated operating current	0.25 A (resistive load)	0.25 A (resistive load)	0.25 A (resistive load)
Maximum switching load	6 W (resistive load)	6 W (resistive load)	6 W (resistive load)
General specifications			
Rated insulation voltage	120 V AC	60 V AC / 75 V DC	120 V AC
Degree of protection	IP67	IP67	IP67
Reverse polarity protection	Yes	Yes	Yes
Housing material	PBT red	PBT red	PBT red
Operating temperature	-25°C to +80°C	-25°C to +80°C	-25°C to +80°C
Output connection	2 m PVC cable, 4 x 0.25 mm ² (2NO or 1NO+1NC) or 6 x 0.25 mm ² (2NO+1 NC)	M8 4-pin connector	Pig tail with M12 connector, L=0.1 m
Vibration resistance	10 g (10...150 Hz)	10 g (10...150 Hz)	10 g (10...150 Hz)
Shock resistance	30 g (11 ms)	30 g (11 ms)	30 g (11 ms)
Approvals/Marks	CE - cULus	CE - cULus	CE - cULus
References - versions without LED			
2 NO outputs	MC88CH20LA2	MC88CH20LM5	MC88CH20LT1
1 NO + 1 NC outputs	MC88CH101CLA2	MC88CH101CLM5	MC88CH101CLT1
2 NO + 1 NC outputs	MC88CH201CLA2		
References - versions with LED			
2 NO outputs	MC88CH20LA2L	MC88CH20LM5L	MC88CH20LT1L
1 NO + 1 NC outputs	MC88CH101CLA2L	MC88CH101CLM5L	MC88CH101CLT1L
2 NO + 1 NC outputs	MC88CH201CLA2L		
LED color	Yellow	Yellow	Yellow
Actuator			
Dimensions (mm)	88 x 25 x 13	88 x 25 x 13	88 x 25 x 13
References	MC88CM1, MC88CM2, MC88CM3	MC88CM1, MC88CM2, MC88CM3	MC88CM1, MC88CM2, MC88CM3

Safety magnetic sensors

Safety magnetic sensors

Types

MC 88C... Right exit

Connections

2 m cable

M8 connector

M12 pig-tail



Dimensions (mm)	88 x 25 x 13	88 x 25 x 13	88 x 25 x 13
Operating frequency	100 Hz	100 Hz	100 Hz
Assured switching distance (Sao)	5 mm (with MC88CM1)	5 mm (with MC88CM1)	5 mm (with MC88CM1)
	8 mm (with MC88CM2)	8 mm (with MC88CM2)	8 mm (with MC88CM2)
	18 mm (with MC88CM3)	18 mm (with MC88CM3)	18 mm (with MC88CM3)
Assured switch-off distance (Sar)	15 mm (with MC88CM1)	15 mm (with MC88CM1)	15 mm (with MC88CM1)
	18 mm (with MC88CM2)	18 mm (with MC88CM2)	18 mm (with MC88CM2)
	30 mm (with MC88CM3)	30 mm (with MC88CM3)	30 mm (with MC88CM3)

Electrical specifications

Rated operating voltage	12-24 VAC/DC	12-24 VAC/DC	12-24 VAC/DC
Rated operating current	0.25 A (resistive load)	0.25 A (resistive load)	0.25 A (resistive load)
Maximum switching load	6 W (resistive load)	6 W (resistive load)	6 W (resistive load)

General specifications

Rated insulation voltage	120 V AC	60 V AC / 75 V DC	120 V AC
Degree of protection	IP67	IP67	IP67
Reverse polarity protection	Yes	Yes	Yes
Housing material	PBT red	PBT red	PBT red
Operating temperature	-25°C to +80°C	-25°C to +80°C	-25°C to +80°C
Output connection	2 m PVC cable, 4 x 0.25 mm ² (2NO or 1NO+1NC) or 6 x 0.25 mm ² (2NO+1 NC)	M8 4-pin connector	Pig tail with M12 connector, L=0.1 m
Vibration resistance	10 g (10...150 Hz)	10 g (10...150 Hz)	10 g (10...150 Hz)
Shock resistance	30 g (11 ms)	30 g (11 ms)	30 g (11 ms)
Approvals/Marks	CE - cULus	CE - cULus	CE - cULus

References - versions without LED

2 NO outputs	MC88CH2ORA2	MC88CH2ORM5	MC88CH2ORT1
1 NO + 1 NC outputs	MC88CH1O1CRA2	MC88CH1O1CRM5	MC88CH1O1CRT1
2 NO + 1 NC outputs	MC88CH2O1CRA2		

References - versions with LED





2 NO outputs	MC88CH2ORA2L	MC88CH2ORM5L	MC88CH2ORT1L
1 NO + 1 NC outputs	MC88CH1O1CRA2L	MC88CH1O1CRM5L	MC88CH1O1CRT1L
2 NO + 1 NC outputs	MC88CH2O1CRA2L		
LED color	Yellow	Yellow	Yellow

Actuator

Dimensions (mm)	88 x 25 x 13	88 x 25 x 13	88 x 25 x 13
References	MC88CM1, MC88CM2, MC88CM3	MC88CM1, MC88CM2, MC88CM3	MC88CM1, MC88CM2, MC88CM3

Safety magnetic sensors

Compact safety magnetic sensors

Types	MC 36C... Left exit		MC 36C... Right exit	
Connections	2 m cable	M8 connector	2 m cable	M8 connector
				
Dimensions (mm)	36 x 26 x 13	36 x 26 x 13	36 x 26 x 13	36 x 26 x 13
Operating frequency	100 Hz	100 Hz	100 Hz	100 Hz
Assured switching distance (Sao)	5 mm (with MC36CM)	5 mm (with MC36CM)	5 mm (with MC36CM)	5 mm (with MC36CM)
Assured switch-off distance (Sar)	15 mm (with MC36CM)	15 mm (with MC36CM)	15 mm (with MC36CM)	15 mm (with MC36CM)
Electrical specifications				
Rated operating voltage	12-24 VAC/DC	12-24 VAC/DC	12-24 VAC/DC	12-24 VAC/DC
Rated operating current	0.25 A (resistive load)	0.25 A (resistive load)	0.25 A (resistive load)	0.25 A (resistive load)
Maximum switching load	6 W (resistive load)	6 W (resistive load)	6 W (resistive load)	6 W (resistive load)
General specifications				
Rated insulation voltage	120 V AC	60 V AC / 75 V DC	120 V AC	60 V AC / 75 V DC
Degree of protection	IP67	IP67	IP67	IP67
Reverse polarity protection	Yes	Yes	Yes	Yes
Housing material	PBT red	PBT red	PBT red	PBT red
Operating temperature	-25°C to +80°C	-25°C to +80°C	-25°C to +80°C	-25°C to +80°C
Output connection	2 m PVC cable 4 x 0.25 mm ²	M8 4-pin connector	2 m PVC cable 4 x 0.25 mm ²	M8 4-pin connector
Vibration resistance	10 g (10...150 Hz)	10 g (10...150 Hz)	10 g (10...150 Hz)	10 g (10...150 Hz)
Shock resistance	30 g (11 ms)	30 g (11 ms)	30 g (11 ms)	30 g (11 ms)
Approvals/Marks	CE - cULus	CE - cULus	CE - cULus	CE - cULus
References - versions without LED				
2 NO outputs	MC36CH20LA2	MC36CH20LM5	MC36CH20RA2	MC36CH20RM5
1 NO + 1 NC outputs	MC36CH101CLA2	MC36CH101CLM5	MC36CH101CRA2	MC36CH101CRM5
References - versions with LED				
2 NO outputs	MC36CH20LA2L	MC36CH20LM5L	MC36CH20RA2L	MC36CH20RM5L
1 NO + 1 NC outputs	MC36CH101CLA2L	MC36CH101CLM5L	MC36CH101CRA2L	MC36CH101CRM5L
LED color	Yellow	Yellow	Yellow	Yellow
Actuator				
Dimensions (mm)	36 x 26 x 13	36 x 26 x 13	36 x 26 x 13	36 x 26 x 13
References	MC36CM	MC36CM	MC36CM	MC36CM

Safety magnetic sensors

Safety magnetic sensors

Types

SMS...

CLS...



Electrical specifications

Max. switch. voltage	100 VAC
Max. switch. power	5 VA
Max. switch. current	0.25 A

General specifications



External dimensions (mm)	M18x1 SMSA2; M30x1.5 SMSA3P	
Suitable magnetic unit	CLSA2 (SMSA2P); CLSA3 (SMSA3P)	
Output connection	Cable (PVC, AWG 22 to 26, L=2 m.);	
Degree of protection	IP67	IP67
Operating temperature	-25°C to +70°C	-25°C to +70°C
Housing material	Plastic; PBT + 30 % glass	Plastic (CLS, CLSA2, CLS3); Stainless steel (CLSA2M)
Approvals/Marks	CE - (UL version is available for some items with different codification)	CE - (UL version is available for some items with different codification)

References

	Safety Aux. Outputs	Aux. Outputs	REFERENCES	Dimensions	REFERENCES
Housing type: Cylindrical Material: Plastic	1NO+1NC		SMSA2P02	Ø25.1 x 9.3	CLSA2
	2NO		SMSA2P03		
	1NO		SMSA2P10		
	2NO		SMSA2P30		
	1NO+1NC		SMSA3P02	Ø30 x 16	CLSA3
	2NO		SMSA3P03		

Intrinsic safety

Explosion proof sensors

Types	Cylindrical series FSQ	Rectangular series MQ	Level series ILM
			
Exter. Dimensions (mm) Float Dimensions (mm)	Ø16 x 110	37 x 16 x 8.3	Spherical Ø 53 [S], Cylindrical Ø 45x55 [C]
Category	2G, 2D	2G, 2D [MQx1EX] 1G, 1D [MQA0EX]	2G, 2D [ILMx2] 1G, 1D [ILMx0]
EX Identification	<ul style="list-style-type: none"> ⊕ II2GExmbIICT5Gb ⊕ II2DExmbIICT100°CDbIP67 	<ul style="list-style-type: none"> ⊕ II2GExmbIICT5Gb [MQx1EX] ⊕ II2DExmbIICT100°CDbIP67 [MQx1EX] ⊕ II1GExialICT6Ga [MQA0EX] ⊕ II1DExialICT100°CDaIP67 [MQA0EX] 	<ul style="list-style-type: none"> ⊕ II2GExmbIICT5Gb [ILMx2] ⊕ II2DExmbIICT100°CDbIP67 [ILMx2] ⊕ II1GExialICT6Ga [ILMx0] ⊕ II1DExialICT100°CDaIP67 [ILMx0]





General specifications

Max. switch. voltage contact	250 VAC	230 VAC/DC [MQA1EX, MQC1EX] 30 VAC/DC [MQA0EX] 150 VAC/DC [MQS1EX]	250 VAC/DC [ILMA2] 230 VAC/DC [ILMS2] 30 VAC/DC [ILMx0]
Max. switch. current contact	3 A	0.25 to 0.75 A [MQx1EX] 120 mA [MQA0EX]	3 A [ILMA2]; 1A [ILMS2] 120 mA [ILMx0]
Max. switch. power contact	100 VA	5 to 10 VA [MQx1EX] - [MQA0EX]	100 VA [ILMA2] 60 VA [ILMS2]
Operating distance	8 - 30 mm	10 - 35 mm	-
Degree of protection	IP67 IP66 (FSQA2HFEX)	IP67	IP67
Temperature Class	T5	T5 [MQx1EX] T6 [MQA0EX]	T5 [ILMx2] T6 [ILMx0]
Body material	Stainless steel AISI 303	Self-exting. PP + 30% glass fiber	Stainless steel AISI 316
Approvals/Marks	CE - TÜV Sud	CE - TÜV Sud	CE - TÜV Sud

References



Normally open	FSQA2B01SLEX FSQA2HFEX	MQA1EX MQA0EX	ILMA2SSLEX ILMA2CSLEX ILMA0SSLEX ILMA0CSLEX
Normally closed		MQC1EX	
Change - Over		MQS1EX	ILMS2SEX ILMS2CEX ILMS0SEX ILMS0CEX

Safety modules





	Emergency stop, safety gates, lift levelling, interlocks		Safety gates	Two hand control
Types	SMS20	SMS31	SMSA31	SM2H21
				
Dimensions HxWxD (mm)	110.8 x 17.5 x 121.1	110.8 x 17.5 x 121.1	110.8 x 17.5 x 121.1	110.8 x 17.5 x 121.1
Safety category	Category 4	Category 4	Category 4	Category 4
Performance Level	PL e (EN ISO 13849-1)	PL e (EN ISO 13849-1)	PL e (EN ISO 13849-1)	PL e (EN ISO 13849-1)
Function	Category 0 emergency stop module, safety gates, safety magnetic switches, interlocks, lift levelling	Category 0 emergency stop module, safety gates, safety magnetic switches, interlocks, lift levelling	Safety gates, safety magnetic switches in antivalent mode	Two hand control Type IIIC
Output specifications				
	2 x NO safety relay	3 x NO safety relay + 1 NC relay	3 x NO safety relay + 1 NC relay	2 x NO safety relay + 1 NC relay, 1 NO PNP
Max. load AC1	6 A @ 250 VAC	6 A @ 250 VAC	6 A @ 250 VAC	6 A @ 250 VAC
Max. load DC1	6 A @ 24 VDC	6 A @ 24 VDC	6 A @ 24 VDC	6 A @ 24 VDC
Electrical life	> 10 ⁵ operations	> 10 ⁵ operations	> 10 ⁵ operations	> 10 ⁵ operations
Input specifications				
Type	2 x NO, voltage free	2 x NO, voltage free	1 x NO + 1 x NC, voltage free	2 x NO, 2 x NC, voltage free
General specifications				
Power supply	24 VDC -10% +10% 24 VAC -15% +10%	24 VDC -10% +10% 24 VAC -15% +10%	24 VDC -10% +10% 24 VAC -15% +10%	24 VDC -10% +10% 24 VAC -15% +10%
Screw terminals	Detachable	Detachable	Detachable	Detachable
Start	Automatic, Manual and Monitored manual	Automatic, Manual and Monitored manual	Automatic, Manual and Monitored manual	Automatic
Approvals/Marks	CE - UL - TÜV - RoHS - EN 81-20, EN 81-50	CE - UL - TÜV - RoHS - EN 81-20, EN 81-50	CE - UL - TÜV - RoHS	CE - UL - TÜV - RoHS
References				
	SMS20	SMS31	SMSA31	SM2H21

Safety modules

Multifunction safety modules

Types	Delayed outputs	Instantaneous outputs	Lift levelling
			
Dimensions HxWxD (mm)	90 x 17.5 x 63	90 x 17.5 x 63	90 x 17.5 x 63
Safety Integrity Level (EN 62061)	SIL CL 3	SIL CL 3	SIL CL 3
Safety Integrity Level (EN 61058)	SIL 3	SIL 3	SIL 3
Performance Level (EN ISO 13849-1:2015)	Cat 4, PL e	Cat 4, PL e	Cat 4, PL e
Lift Standards	-	-	EN 81-20 EN 81-50
Function	Category 0 emergency stop module, safety gates, safety magnetic switches, interlocks, safety light curtains (ESPE Type 4, Type 2), safety mats. Selectable delay time through HEX switch	Category 0 emergency stop module, safety gates, safety magnetic switches, interlocks, safety light curtains (ESPE Type 4, Type 2), safety mats.	Category 0 emergency stop module, safety gates, safety magnetic switches, interlocks, safety light curtains (ESPE Type 4, Type 2), safety mats. Control of levelling, re-levelling and preliminary operation with doors not closed and locked
Output specifications			
Safety Output / Auxiliary Output	2 x OSSD direct + 2 x OSSD delayed	4 x OSSD (NO)	3 x OSSD (NO) + 1 OSSD Auxiliary (1 NC)
Max. load DC24	≤400 mA	≤400 mA	≤400 mA
Input specifications			
Type	24 VDC, >12 V = High, <2 V = Low, >6 mA min current	24 VDC, >12 V = High, <2 V = Low, >6 mA min current	24 VDC, >12 V = High, <2 V = Low, >6 mA min current
General specifications			
Power supply	24 VDC ± 20%	24 VDC ± 20%	24 VDC ± 20%
Screw terminals	Fixed	Fixed	Fixed
Start	Manual or automatic start selectable	Manual or automatic start selectable	Manual or automatic start selectable
Approvals/Marks	CE - TÜV - cULus - RoHS	CE - TÜV - cULus - RoHS	CE - TÜV - cULus - RoHS
References			
	CM22D0A	CM40D0A	CM30D1A
			CL20D2A

Safety modules

	Safety expansion unit	Safety mat & edge		Safety light curtains
Types	SME41	NSE02C	NST02C	NLG02D/NLG13D
				
Dimensions HxWxD (mm)	110.8 x 17.5 x 121.1	84 x 22.5 x 100	84 x 22.5 x 100	99 x 22.5 x 114
Safety category	Category 4	Category 3 (EN ISO 13849-1)	Category 3 (EN ISO 13849-1)	Category 4 (EN ISO 13849-1)
Performance Level	PL e (EN ISO 13849-1)	PL d (EN ISO 13849-1)	PL d (EN ISO 13849-1)	PL e (EN ISO 13849-1)
Function	Safety expansion relay unit	Safety mat & edge module	Safety mat module	Light curtains safety modules
Output specifications				
	4 x NO safety relay + 1 x NC relay	2 x NO safety relay	2 x NO safety relay	3 x NO safety relay + 1 NC relay
Max. load AC1	6 A @ 250 VAC	5 A @ 230 VAC	5 A @ 230 VAC	6 A @ 230 VAC
Max. load DC1	6 A @ 24 VDC	5 A @ 24 VDC	5 A @ 24 VDC	6 A @ 24 VDC
Electrical life	> 10 ⁵ operations	> 10 ⁵ operations	> 10 ⁵ operations	> 10 ⁵ operations
Input specifications				
Type	2 x NO, voltage free or OSSD	2-wire mats or safety edges	4-wire mats	2 x NO min 10 mA / 17 V max 60 mA / 38 V [NLG02] max 30 mA / 38 V
General specifications				
Power supply	24 VDC -10% +10% 24 VAC -15% +10%	24 VAC/DC ±15%	24 VAC/DC ±15%	24 VDC - 15% +10%
Screw terminals	Detachable	Fixed	Fixed	Fixed [SA, SC] Detachable [DA, DC]
Start	-	Automatic / Manual [SA] Monitored manual [SC]	Automatic / Manual [SA] Monitored manual [SC]	Automatic / Manual [SA, DA] Monitored manual [SC, DC]
Approvals/Marks	CE - UL - TÜV - RoHS	CE - TÜV - RoHS	CE - TÜV - RoHS	CE - UL - TÜV - RoHS
References				
	SME41	NSE02CB24SA NSE02CB24SC	NST02CB24SA NST02CB24SC	NLG02D724SA NLG02D724SC NLG02D724DA NLG02D724DC NLG13D724SA NLG13D724SC NLG13D724DA NLG13D724DC

Configurable safety modules

Configurable master module

Types

CMM



Dimensions HxWxD (mm)	108 x 22.5 x 114.5
Safety Level	Safety Integrity Level SIL 3, according to EN 61508 Safety Integrity Level SIL CL 3, according to EN 62061 Performance Level PL e and Cat. 4, according to EN ISO 13489-1
Function	Monitors and controls different safety signals; able to control single and multiple safety circuits. Manages up to 14 expansion units leaving out C2 R/C4 R modules

Safety inputs and outputs specifications

CMM as a stand alone unit	- 8 digital inputs, PNP active high according to EN 61131-2 - 2 pairs of solid state programmable safety outputs (OSSD), PNP active high 400 mA at 24 VDC max
Max. digital inputs with expansion modules	128
Max. digital outputs with expansion modules	16 pairs (OSSD)
Max. n° of expansion modules	14, leaving out C2 R/C4 R modules

Non-Safety inputs and outputs specifications

Test outputs	4
Programmable digital signal outputs	2
Input for Start/Restart interlock and EDM	2

General specifications

Rated voltage	24 VDC ±20% / supply from Class II
Digital inputs	PNP active high, according to EN 61131-2
OSSD	PNP active high - 400 mA @ 24 VDC (every OSSD)
Enclosure protection class	IP20
Terminal blocks protection class	IP2x

I/O Expansion modules

Types

C 8I 2O

C 8I / C 16I

C 12I 8TO







Dimensions HxWxD (mm)	108 x 22.5 x 114.5	108 x 22.5 x 114.5	108 x 22.5 x 114.5
Performance Level	Cat. 4, PL e (EN ISO 13849-1)	Cat. 4, PL e (EN ISO 13849-1)	Cat. 4, PL e (EN ISO 13849-1)
Safety Integrity Level	SIL 3 (EN 61508)	SIL 3 (EN 61508)	SIL 3 (EN 61508)
Function	Expansion modules	Expansion modules	Expansion modules



General specifications

PFHd (IEC 61508:1998)	5.72E-9	5.75E-9 [C 8I] 7.09E-9 [C 16I]	3.24E-9
Rated voltage	24 VDC ±20%	24 VDC ±20%	24 VDC ±20%
Dissipated power	3 W max	3 W max	3 W max
Digital inputs	8 / PNP active high according to EN 61131-2 [C 8I 2O]	PNP active high according to EN 61131-2 8 [C 8I] / 16 [C 16I]	12 / PNP active high according to EN 61131-2 [C 12I 8TO]
Digital output	2 OSSD pairs with 400 mA output current		
Test output	4 for sensor monitoring and checking short-circuits and overloads	4 for sensor monitoring and checking short-circuits and overloads	8 for sensor monitoring and checking short-circuits and overloads

Configurable safety modules

	OSSD	Relay expansion modules
Types	C 2OSSD / C 4OSSD	C 2R / C 4R
		
Dimensions HxWxD (mm)	108 x 22.5 x 114.5	108 x 22.5 x 114.5
Performance Level	Cat. 4, PL e (EN ISO 13849-1)	Cat. 4, PL e (EN ISO 13849-1)
Safety Integrity Level	SIL 3 (EN 61508)	SIL 3 (EN 61508)
Rated voltage	24 VDC ±20%	24 VDC ±20%
Function	Expansion modules	Expansion modules
General specifications		
PHFd (IEC 61508:1998)	3.16E-9 [C 2OSSD] / 3.44E-9 [C 4OSSD]	
Dissipated power	3 W max	3 W max
Digital output	PNP active high 2 [C 2OSSD]; PNP active high 4 [C 4OSSD]	
Switching voltage		240 VAC
Switching current		6 A max
Contacts		2 NO + 1 NC [C 2R] connectable to 1 OSSD pair 4 NO + 2 NC [C 4R] connectable to 2 OSSD pairs
Feedback contacts		1 NC [C 2R] / 2 NC [C 4R]
Speed monitoring modules		
Types	C PSS	C ES1 / C ES2
		
Dimensions HxWxD (mm)	108 x 22.5 x 114.5	108 x 22.5 x 114.5
Performance Level	Cat. 4, PL e (EN ISO 13849-1)	Cat. 4, PL e (EN ISO 13849-1)
Safety Integrity Level	SIL 3 (EN 61508)	SIL 3 (EN 61508)
Rated voltage	24 VDC ±20%	24 VDC ±20%
Function	Can be used to control the following: Zero speed, Max. speed, Speed range; Direction of movement, rotation/translation; Up to 4 speed thresholds can be set for each logic output (axis). Each unit incorporates two logic outputs that can be configured using the software and is thus capable of controlling up to two independent axes	Can be used to control the following: Zero speed, Max. speed, Speed range; Direction of movement, rotation/translation; Up to 4 speed thresholds can be set for each logic output (axis). Each unit incorporates two logic outputs that can be configured using the software and is thus capable of controlling up to two independent axes
General specifications		
Dissipated power	3 W max	3 W max
Max number of axis	2	2
2 proximity inputs	2 axis Sin/Cos + 1 or 2 proximity [C PSS]	
1 encoder e 2 proximity inputs		1 encoder TTL 5V + 1 or 2 proximity [C ES1T] 1 encoder HTL + 1 or 2 proximity [C ES1H]
2 encoder e 2 proximity inputs		2 encoder TTL + 1 or 2 proximity [C ES2T] 2 encoder HTL + 1 or 2 proximity [C ES2H] 2 encoder Sin/Cos + 1 or 2 proximity [C ES2S]

Configurable safety modules

	Data and diagnostics communication modules	Bus transfer expansion modules
Types	C DDC	C BT
		
Dimensions HxWxD (mm)	108 x 22.5 x 114.5	108 x 22.5 x 114.5
Performance Level	Cat. 4, PL e (EN ISO 13849-1)	Cat. 4, PL e (EN ISO 13849-1)
Safety Integrity Level	SIL 3 (EN 61508)	SIL 3 (EN 61508)
Rated voltage	24 VDC ±20%	24 VDC ±20%
Function	Communication with most common industrial fieldbus systems	Interface expansion module allowing the connection of remote expansions. Ideal solution for the interconnection of the safety functions of several machines in a production line
General specifications		
Connection		Shielded cable compatible with RS485
Max connection distance		50 m
Max number of CBT modules per system		6
References	Profibus [C PFBUS] DeviceNET [C DNET] CANopen [C CAN] Ethernet IP [C EIP] EtherCAT [C ECAT] PROFINET [C PFNET] Universal Serial Bus [C OMMS]	1 connection (1 input or 1 output) [C BT1] 2 connections (1 input and 1 output) [C BT2] The C BT1 is placed at the beginning or at the end of the network connected with a single cable, whilst the C BT2 goes in the middle.

Limit switches



	PS21L	PS21L	PS31L	PS31L
Housing material	Plastic	Metal	Plastic	Metal
Housing dimensions WxHxD (mm)	30.3 x 63 x 30	30.3 x 65 x 32.5	41 x 74 x 40.5	40 x 76.5 x 43

Actuator type

Nylon roller external bent lever	BE	BE	-	-
Metal roller bent lever	-	BM	-	-
Nylon roller internal bent lever	BR	BR	-	-
Adjustable stainless steel rod lever	LA	LA	LA	LA
Nylon actuator stainless steel spring	LB	LB	-	-
Adjustable fiberglass rod lever	LG	LG	LG	LG
Steel plunger nylon roller + gasket	LO	-	-	-
Multidir. nylon actuator stainless spring	LP	-	LP	LP
Stainless spring multidirection actuator	LS	-	LS	LS
Stainless spring multidirection cat whisker actuator	LW	-	LW	LW
Pull wire	N6	-	N6	-
Metal plain plunger	P0	P0	P0	P0
Metal plain plunger + gasket	PH	-	PH	PH
Metal roller plunger	PR	PR	PR	PR
Adjustable lever nylon roller	R1	R1	R1	R1
Adjustable lever stainless steel roller	-	-	R2	R2
Plastic roller lever on metal plunger left	RH	-	RH	RH
Nylon roller lever	RT	RT	RT	RT
Plastic roller lever on metal plunger right	RV	-	-	-
Ø50 rubber roller lever	W0	W0	W0	W0
Adjustable lever Ø50 rubber roller	W1	W1	W1	W1

Contacts

Snap 1NO+1NC	↔	S11	S11	S11	S11
Slow 1NO+1NC	↔	T11	T11	T11	T11
Slow Overlap 1NO+1NC	↔	O11	O11	O11	O11
Slow 2NO		T20	T20	T20	T20
Slow 2NC	↔	T02	T02	T02	T02
Snap 2NC	↔	S02	S02	S02	S02
Slow 1NO+2NC	↔	-	-	T12	T12
Slow 2NO+1NC	↔	-	-	T21	T21
Slow 3NC	↔	-	-	T03	T03
Slow 3NO		-	-	T30	T30

General specifications

Connection	Selectable cable gland M20, M16, PG13.5, PG11, 1/2NPT			
Degree of protection	IP65	IP66 (IP65 with LG, W1 actuator)	IP65	IP66 (IP65 with LP, LS, W1 actuator)
Rated insulation voltage U_i	500 V ($S02 - U_i=400V$)			
according to IEC 60947-1 and EN 60947-1				
according to UL 508, CSA C22-2 n°14	A 600, Q 600	A 300, Q 300	A 600, Q 600	A 600, Q 600
Rated impulse withstand voltage U_{imp}	6 kV			
Rated operational current	6 A (3 A - S02)			
IEC 60947-5-1 - Ie/AC-15 240 VAC	6 A (3 A - S02, T12, T21, T03, T30)			
IEC 60947-5-1 - Ie/DC-13 24 VDC	6 A (2.8 A - T12, T21, T03, T30)			
UL 508, CSA C22-2 n°14	A 600, Q 600	A 300, Q 300	A 600, Q 600	A 600, Q 600
Electrical durability (IEC 60947-5-1)	3600 cycles/h			
Max. switching frequency	0.5			
Load factor	-25°C to +70°C			
Operating temperature	CE - UL - CSA			
Approvals				
Mechanical durability (different by head type)	5x10 ⁶ ÷ 15x10 ⁶ operations	10x10 ⁶ ÷ 15x10 ⁶ operations	10x10 ⁶ ÷ 30x10 ⁶ operations	10x10 ⁶ ÷ 30x10 ⁶ operations
B10d (different by head type)	10x10 ⁶ ÷ 30x10 ⁶ operations	20x10 ⁶ ÷ 30x10 ⁶ operations	20x10 ⁶ ÷ 60x10 ⁶ operations	20x10 ⁶ ÷ 60x10 ⁶ operations

Limit switches



	PS42L	PS42L	PS43L
Housing material	Plastic	Metal	Metal
Housing dimensions WxHxD (mm)	50 x 56 x 33	52 x 64.5 x 36	60 x 75.5 x 36

Actuator type

	PS42L	PS42L	PS43L
Nylon roller external bent lever	BE	BE	-
Metal roller bent lever	-	BM	-
Nylon roller internal bent lever	BR	BR	-
Adjustable stainless steel rod lever	LA	LA	LA
Nylon actuator stainless steel spring	-	LB	LB
Adjustable fiberglass rod lever	LG	LG	LG
Steel plunger nylon roller + gasket	LO	-	-
Multidir. nylon actuator stainless spring	LP	-	LP
Stainless spring multidirection actuator	LS	-	LS
Stainless spring multidirection cat whisker actuator	LW	-	LW
Pull wire	N6	-	N6
Metal plain plunger	P0	P0	P0
Metal plain plunger + gasket	PH	-	-
Metal roller plunger	PR	PR	PR
Adjustable lever nylon roller	R1	R1	R1
Plastic roller lever on metal plunger left	RH	-	RH
Nylon roller lever	RT	RT	RT
Ø50 rubber roller lever	W0	W0	W0
Adjustable lever Ø50 rubber roller	W1	W1	W1

Contacts



	PS42L	PS42L	PS43L
Snap 1NO+1NC	⊕	S11	S11
Slow 1NO+1NC	⊕	T11	T11
Slow Overlap 1NO+1NC	⊕	O11	O11
Slow 2NO		T20	T20
Slow 2NC	⊕	T02	T02
Snap 2NC	⊕	S02	S02
Slow 1NO+2NC	⊕	-	T12
Slow 2NO+1NC	⊕	-	T21
Slow 3NC	⊕	-	T03
Slow 3NO		-	T30

General specifications

Connection	Selectable cable gland M20, M16, PG13.5, PG11, 1/2NPT		
Degree of protection	IP65	IP66 (IP65 with LG, W1 actuator)	IP66 (IP65 with LP, LS, W1 actuator)
Rated insulation voltage U_i	500 V (S02 - $U_i=400V$)		
according to IEC 60947-1 and EN 60947-1			
according to UL 508, CSA C22-2 n°14	A 600, Q 600	A 300, Q 300	A 600, Q 600
Rated impulse withstand voltage U_{imp}	6 kV		
Rated operational current	6 A (3 A - S02)		
IEC 60947-5-1 - Ie/AC-15 240 VAC	6 A		6 A (3 A - S02, T12, T21, T03, T30)
IEC 60947-5-1 - Ie/DC-13 24 VDC	6 A		6 A (2.8 A - T12, T21, T03, T30)
UL 508, CSA C22-2 n°14	A 600, Q 600	A 300, Q 300	A 600, Q 600
Electrical durability (IEC 60947-5-1)	3600 cycles/h		
Max. switching frequency	0.5		
Load factor	-25°C to +70°C		
Operating temperature	CE - UL - CSA		
Approvals	5x10 ⁶ ÷ 15x10 ⁶ operations		
Mechanical durability (different by head type)	10x10 ⁶ ÷ 15x10 ⁶ operations	20x10 ⁶ ÷ 30x10 ⁶ operations	10x10 ⁶ ÷ 30x10 ⁶ operations
B10d (different by head type)	10x10 ⁶ ÷ 30x10 ⁶ operations	20x10 ⁶ ÷ 30x10 ⁶ operations	20x10 ⁶ ÷ 60x10 ⁶ operations

Limit switches



	PS21M	PS21M	PS31M	PS31M
Housing material	Plastic	Metal	Plastic	Metal
Housing dimensions WxHxD (mm)	30 x 49 x 16	30 x 49 x 16	35 x 49 x 16	35 x 49 x 16
Actuator type				
Adjustable stainless steel rod lever	LA	LA	LA	LA
Stainless spring multidir. actuator	LS	LS	LS	LS
Metal plain plunger	P0	P0	P0	P0
Cross metal roller plunger	P9	P9	P9	P9
Metal plain plunger + gasket	PH	PH	PH	PH
Metal roller plunger	PR	PR	PR	PR
Adjustable lever nylon roller	R1	R1	R1	R1
Metal roller lever	RS	RS	RS	RS
Nylon roller lever	RT	RT	RT	RT
Contacts				
Snap 1NO+1NC 	S11	S11	S11	S11
Slow 1NO+1NC 	T11	T11	T11	T11
General specifications				
Connection	1m PVC cable, 4x0.75 mm	1m PVC cable, 5x0.75 mm	1m PVC cable, 4x0.75 mm	1m PVC cable, 5x0.75 mm
Degree of protection	IP67			
Rated insulation voltage Ui	400 V			
according to IEC 60947-1 and EN 60947-1	400 V			
according to UL 508, CSA C22-2 n°14	B 300, R 300			
Rated impulse withstand voltage Uimp	4 kV			
Rated operational current	3 A			
IEC 60947-5-1 - Ie/AC-15 240 VAC	3 A			
IEC 60947-5-1 - Ie/DC-13 24 VDC	2.8 A			
UL 508, CSA C22-2 n°14	B 300, R 300			
Electrical durability (IEC 60947-5-1)	3600 cycles/h			
Max. switching frequency	0.5			
Load factor	-25°C to +70°C			
Operating temperature	CE - UL - CSA			
Approvals	10x10 ⁶ operations			
Mechanical durability	20x10 ⁶ operations			
B10d				

Safety Interlocks and Safety Hinges

Electromagnetic Safety Interlock

Safety Hinges



Electrical interlock

Mechanical interlock

Plug

Cable

Housing material	Plastic		Plastic	
Dimensions WxHxD (mm)	40 x 190 x 42		60 x 110 x 25	

Contacts





1NO + 2NC (Coil) + 1NC (Actuator)	ESI311E024	ESI311M024		
1NO + 2NC (Coil) + 1NO (Actuator)	ESI221E024	ESI221M024		
2NC (Coil) + 1NO + 1NC (Actuator)	ESI131E024	ESI131M024		
Slow action: 2NO + 2NC			PS38H-IT2205-T01	PS38H-CT2205-T01
Slow action: 1NO + 3NC			PS38H-IT1305-T01	PS38H-CT1305-T01

General specifications





Connection	M20 cable inlet	M12 plug	2 m PVC cable
Degree of protection	IP65	IP67	
Rated insulation voltage (Ui)			
according to IEC 60947-1 and EN 60947-1	250 V	24 V	400 V
according to UL 508, CSA C22-2 n°14	A 300, Q 300	Class II	C 300, Q 300
Rated impulse withstand voltage U _{imp}	2.5 kV	2.5 kV	4 kV
Rated operational current			
I _e /AC-15 230 VAC	4 A	4 A (250 VAC)	
I _e /DC-13 24 VDC	4 A	2 A	
Electrical durability (IEC 60947-5-1)			
Max. switching frequency	600 cycles/h	1200 cycles/h	
Load factor	0.5	0.5	
Temperature ratings			
Operating temperature	-25°C to +55°C	-20°C to +80°C	
Storage temperature	-30°C to +80°C	-20°C to +80°C	
Max actuating speed	20 m/min		
Retention force at locked actuator	1200 N		
Mechanical durability	1x10 ⁶ operations	1x10 ⁶ operations	
B10d	4x10 ⁶ operations	2x10 ⁶ operations	
Key actuator orientation	Adjustable head orientation, frontal, 90°, 180° and 270°; default frontal orientation		
Conformance	Interlock type 2 in accordance with EN ISO 14119 LVD 2014/35/EU in accordance with EN/IEC 60947-5-1 Machinery Directive 2006/42/CE SILCL 3 in accordance with EN 62061 PL e in accordance with EN ISO 13849-1		Interlock type 1 in accordance with EN ISO 14119 LVD 2014/35/EU in accordance with EN/IEC 60947-5-1 Machinery Directive 2006/42/CE SILCL 3 in accordance with EN 62061 PL e in accordance with EN ISO 13849-1
Approvals	CE - UL - CSA		CE - UL - CSA

Safety limit switches

Key Actuator 90° or adjustable head (key must be ordered separately)

				
	PS21S	PS31S	PS42S	PS43S
Housing material	Plastic	Metal	Metal	Metal
Dimensions WxHxD (mm)	30.3 x 90 x 30	41.3 x 109.5 x 41	57 x 83 x 33	43 x 104.5 x 66
Contacts				
Snap 1NO+1NC	↔ S11	S11	S11	S11
Snap 2NC	↔ S02	S02	S02	S02
Slow 1NO+1NC	↔ T11	T11	T11	T11
Slow Overlap 1NO+1NC	↔ O11	O11	O11	O11
Slow 2NC	↔ T02	T02	T02	T02
Slow 2NO+1NC	↔ -	T21	-	T21
Slow 1NO+2NC	↔ -	T12	-	T12
Slow 3NC	↔ -	T03	-	T03
Specifications				
Degree of protection	IP65	IP66	IP66	IP66
Rated insulation voltage (Ui)				
according to IEC 60947-1 and EN 60947-1	500 V (S02 - Ui=400V)	500 V (S02, T12, T21, T03 - Ui=400V)	500 V (S02 - Ui=400V)	500 V (S02, T12, T21, T03 - Ui=400V)
according to UL 508, CSA C22-2 n°14	A 600, Q 600	A 600, Q 600	A 300, Q 300	A 600, Q 600 (T12, T21, T03 - A300, Q300)

Pull wire actuator, with or without manual reset

				
	PS21R	PS31R	PS42R	PS43R
Housing material	Metal	Metal	Metal	Metal
Dimensions WxHxD (mm)	30.3 x 145.75 x 32.5	40 x 162.75 x 43	52 x 145.25 x 36	63 x 158.25 x 43
Contacts				
Snap 1NO+1NC	↔ S11	S11	S11	S11
Snap 2NC	↔ S02	S02	S02	S02
Slow 1NO+1NC	↔ T11	T11	T11	T11
Slow Overlap 1NO+1NC	↔ O11	O11	O11	O11
Slow 2NC	↔ T02	T02	T02	T02
Slow 2NO+1NC	↔ -	T21	-	T21
Slow 1NO+2NC	↔ -	T12	-	T12
Slow 3NC	↔ -	T03	-	T03
Specifications				
Without reset button	N6-Y00	N6-Y00	N6-Y00	N6-Y00
With manual reset button	N7-YK0	N7-YK0	N7-YK0	N7-YK0
Degree of protection	IP66	IP66	IP66	IP66
Rated insulation voltage (Ui)				
according to IEC 60947-1 and EN 60947-1	500 V (S02 - Ui=400V)	500 V (S02, T12, T21, T03 - Ui=400V)	500 V (S02 - Ui=400V)	500 V (S02, T12, T21, T03 - Ui=400V)
according to UL 508, CSA C22-2 n°14	A 300, Q 300	A 600, Q 600 (A300, Q300 - T12, T21, T03)	A 300, Q 300	A 600, Q 600 (A300, Q300 - T12, T21, T03)

General specifications

Connection	Selectable cable gland M20, M16, PG13,5, PG11, 1/2NPT			
Rated impulse withstand voltage U_{imp}	6 kV			
Rated operational current				
IEC 60947-5-1 - Ie/AC-15 240 VAC	6 A (3 A - S02)	6 A (3 A - S02, T12, T21, T03)	6 A (3 A - S02)	6 A (3 A - S02, T12, T21, T03)
IEC 60947-5-1 - Ie/DC-13-24 VDC	6 A	6 A (2,8 A - T12, T21, T03)	6 A	6 A (2,8 A - T12, T21, T03)
UL 508, CSA C22-2 n°14	A 300, Q 300	A 600, Q 600	A 300, Q 300	A 600, Q 600 (T12, T21, T03 - A300, Q300)
Electrical durability (IEC 60947-5-1)				
Max. switching frequency	3600 cycles/h			
Load factor	0,5			
Operating temperature	-25 to +70°C			
Approvals	CE - UL - CSA			
Mechanical durability	1x10 ⁶ operations			
BT0d	2x10 ⁶ operations			

Sensors

Safety limit switches and Limit switches with reset button



Hinge Switches operated lever

Limit Switches with Reset button



	PS21H	PS21H	PS21K	PS21K
Housing material	Plastic	Plastic	Plastic	Metal
Housing dimensions WxHxD (mm)	30.3 x 79.5 x 42	30.3 x 79.5 x 51.2	30.3 x 63 x 30	30.3 x 65 x 32.5
Actuator type				
Hinged steel lever	HC	-	-	-
Shaft for hinge	-	HZ	-	-
Nylon roller internal bent lever	-	-	BR	BR
Metal plain plunger	-	-	PO	PO
Metal roller plunger	-	-	PR	PR
Nylon roller lever	-	-	RT	RT
Contacts				
Snap 1NO+1NC	⊕ S11	S11	S11	S11
Snap 2NC	⊕ S02	S02	S02	S02
Slow 1NO+1NC	⊕ T11	T11	T11	T11
Slow Overlap 1NO+1NC	⊕ O11	O11	-	-
Slow 2NC	⊕ T02	T02	T02	T02
General specifications				
Connection	Selectable cable gland M20, M16, PG13.5, PG11, 1/2NPT		Selectable cable gland M20, M16, PG13.5, PG11, 1/2NPT	
Degree of protection	IP65		IP65 IP66	
Rated insulation voltage U_i	500 V (S02 - $U_i=400V$)		500 V (S02 - $U_i=400V$)	
according to IEC 60947-1 and EN 60947-1	500 V (S02 - $U_i=400V$)		500 V (S02 - $U_i=400V$)	
according to UL 508, CSA C22-2 n°14	A 600, Q 600		A 600, Q 600 A 300, Q 300	
Rated impulse withstand voltage U_{imp}	6 kV		6 kV	
Rated operational current	6 A (3 A - S02)		6 A (3 A - S02)	
IEC 60947-5-1 - $I_e/AC-15$ 240 VAC	6 A (3 A - S02)		6 A (3 A - S02)	
IEC 60947-5-1 - $I_e/DC-13-24$ VDC	6 A		6 A	
UL 508, CSA C22-2 n°14	A 600, Q 600		A 600, Q 600 A 300, Q 300	
Electrical durability (IEC 60947-5-1)	3600 cycles/h		3600 cycles/h	
Max. switching frequency	3600 cycles/h		3600 cycles/h	
Load factor	0.5		0.5	
Operating temperature	-25°C to +70°C		-25°C to +70°C	
Approvals	CE - UL - CSA		CE - UL - CSA	
Mechanical durability	1x10 ⁶ operations		1x10 ⁶ operations	
B10d	2x10 ⁶ operations		2x10 ⁶ operations	

Connectivity

	YN115	YL212
Function	IO-Link masters	IO-Link masters
		
Dimensions (mm)	99 x 45 x 114	212 x 65 x 30
Description	DIN rail mount fieldbus module	Machine mount fieldbus module
Function	Gateway between the controller of an EtherNet/IP™ [YN115CEI8RPIO] or PROFINET IO [YN115CPN8RPIO] fieldbus system and up to 8 IO-Link devices. Integrated web server and IODD interpreter for easy remote configuration and diagnostic of the module and attached IO-Link devices	Gateway between the controller of an EtherNet/IP™ [YL212CEI8M1IO] or PROFINET IO [YL212CPN8M1IO] fieldbus system and up to 8 IO-Link devices. Integrated web server and IODD interpreter for easy remote configuration and diagnostic of the module and attached IO-Link devices
Housing type	DIN rail mount enclosure	Machine mounting
Power Supply		
Supply voltage	18 - 30 VDC	20 - 30 VDC
Power connector type	Pluggable spring clamp or screw terminal blocks	1 power input + 1 power output; M12, L-coded, 4 + FE
IO-Link ports, configurable		
Channels	8 x IO-Link/Digital I/O (configurable), 8 x DI	8 x IO-Link/Digital I/O (configurable), 8 x DI
Connectors type	Pluggable spring clamp or screw terminal blocks	M12, A-coded Female
IO-Link version	V1.0 and V1.1	V1.0 and V1.1
Sensor supply	200 mA	1,6 A (Port 1), 1.0 A (Port 3), 500 mA (Port2, 4-8, each)
Output current [I _e]	200 mA per port via C/Q (pin 4)	200 mA per port via C/Q (pin 4)
IO-Link Mode Transfer Rates	4.8K (COM1); 38.4K (COM2); 230.4K (COM3)	4.8K (COM1); 38.4K (COM2); 230.4K (COM3)
Short circuit protection	Yes	Yes
Ethernet ports		
Number of ports and type	2, Industrial Ethernet	2, Industrial Ethernet
Connector type	RJ45	Fieldbus M12 D-coded
Transfer rate	10/100 Mbps	10/100 Mbps
Rotary switches for IP address setting		Yes
Protocols		
Simultaneous data access via different communication protocols	Yes	Yes
EtherNet/IP™	Yes [YN115CEI..]	Yes [YL212CEI8M1IO]
PROFINET IO	Yes [YN115CPN..]	Yes [YL212CPN8M1IO]
MODBUS TCP	Yes	Yes
OPC UA	Yes	Yes
IIoT and Industry 4.0		
OPC UA integrated web server	Allows Continuous and transparent data transfer between the field level and higher-level cloud systems	Allows Continuous and transparent data transfer between the field level and higher-level cloud systems
General specifications		
User interface	Web-based configuration of module and IO-Link devices	Web-based configuration of module and IO-Link devices
Indication	Multi-colour LEDs for device, network, and port status diagnostics	Multi-colour LEDs for device, network, and port status diagnostics
Degree of protection	IP20	IP67
Ambient air temperature	-40° to +70°C	-25° to +60°C
Storage temperature	-40°C to +85°C	-40°C to +70°C
Ambient humidity range	10% to 95%	10% to 95%
Approvals/Marks	CE - cULus - FCC	CE - cULus - FCC
Accessories		
Included accessories	Pluggable/removable spring clamp & screw terminal blocks for IO-Link and Power	
References		
EtherNet/IP™	YN115CEI8RPIO	YL212CEI8M1IO
PROFINET IO	YN115CPN8RPIO	YL212CPN8M1IO

Connectivity

SCTL55

Function Smart configurator for IO-Link sensors



Dimensions (mm)	62 x 222 x 90
Description	Portable self-powered device for an easy control, diagnosis and parameterization of IO-Link sensors
Function	<p>Intuitive GUI with dedicated App for a simplified user experience.</p> <p>Access to an advanced diagnostics with the possibility to verify operating hours, number of detections, operating cycles, alarms and quality of run of the sensor connected.</p> <p>Easy management of operating parameters such as switchpoint mode, logic and timing functions, sensing distance, output configuration (PNP/NPN/push-pull, NO/NC).</p>
Housing type	Handheld
IO-Link interface	
Supply voltage	24 VDC \pm 20%
Maximum load	80 mA/Short circuit protected
Incorrect polarity protection	Yes
Connectors to sensor	Plug type: M8 3-wire, M8 4-wire and M12
IO-Link protocol support	IO-Link v1.1
IO-Link file administration	
Wi-Fi	Automatic download of IODD file via Configure App
Micro SD card	Import and save IODD file from/to Micro SD card (not included)
Electrical ratings and battery information	
Standard charger via micro USB	5 V/1 A or PC USB port
Battery type	High capacity LI-ION rechargeable battery
Operating time (with sensor connected)	Full operation: > 5 hours; Screen off: > 22 hours
Standby time	Device completely off: 6 months
General specifications	
User interface	High definition 5.5" touchscreen display, 720 x 1280 pixels
Indication	5 LEDs for main battery status LEDs for Power, IO-Link, Error, SIO2 and USB
Degree of protection	IP30
Pollution degree	2
Ambient air temperature	Charging: 10°C to +35°C; Operating: 0°C to +40°C
Storage temperature	0°C to +50°C
Ambient humidity range	Operating: 0 to 90% non condensing; Storage: 0 to +90% non condensing
Operating system	Carlo Gavazzi Store with dedicated Apps
Memory	Large internal memory, expandable with Micro SD card
App	"Configure" App with customized home page for each Carlo Gavazzi sensors family
Approvals/Marks	CE - RoHS - FCC - IC
Accessories	
Included accessories	Protective holster. Extension cable: 0.5 m M12 to 4 hooks for cable type sensors. Lanyard.
References	
5.5" touch screen display	SCTL55

Connectivity

Cordsets



Dimensions (mm)	Straight M8 connector PVC cable	Angled M8 connector PVC cable	Straight M8 connector PVC cable	Angled M8 connector PVC cable
Used for	3-wire DC sensors	3-wire DC sensors	4-wire DC sensors	4-wire DC sensors
2 m cable	CONE53NF-S2	CONE53NF-A2	CONE54NF-S2	CONE54NF-A2
5 m cable	CONE53NF-S5	CONE53NF-A5	CONE54NF-S5	CONE54NF-A5
Degree of protection	IP67	IP67	IP67	IP67
PUR version	Add "P" at the end of the part number	Add "P" at the end of the part number	Add "P" at the end of the part number	Add "P" at the end of the part number



Dimensions (mm)	Straight M12 connector TPE cable	Angled M12 connector TPE cable	Straight M12 connector PVC cable	Angled M12 connector PVC cable
Used for	4-wire DC	4-wire DC	3-, 4- or 5-wire DC	3-, 4- or 5-wire DC
2 m cable, 3-pin			CONE13NF-S2	CONE13NF-A2
5 m cable, 3-pin			CONE13NF-S5	CONE13NF-A5
2 m cable, 4-pin	CONB14NF-S2W	CONB14NF-A2W	CONE14NF-S2	CONE14NF-A2
5 m cable, 4-pin	CONB14NF-S5W	CONB14NF-A5W	CONE14NF-S5	CONE14NF-A5
10 m cable, 4-pin			CONE14NF-S10	CONE14NF-A10
2 m cable, 5-pin			CONE15NF-S2	CONE15NF-A2
5 m cable, 5-pin			CONE15NF-S5	CONE15NF-A5
Degree of protection	IP69K	IP69K	IP67	IP67
PUR version			Add "P" at the end of the part number	Add "P" at the end of the part number



Dimensions (mm)	Straight M12 connector PVC cable	Angled M12 connector PVC cable	Straight M12 connector Terminal connection	Angled M12 connector Terminal connection
Used for	2-wire AC	2-wire AC	4-wire DC	4-wire DC
2 m cable, 3-pin	CONH6A-S2	CONH6A-A2		
5 m cable, 3-pin	CONH6A-S5	CONH6A-A5		
No cable 4-pin			CONE14NF-S	CONE14NF-A
Degree of protection	IP67	IP67	IP67	IP67

Connectivity

Brackets angled



Steel, galvanized	AMB8-A	AMB12-A	AMB18-A	AMB30-A
Stainless steel AISI316L	-	AMB12-A316L	AMB18-A316L	-
Used for	M8 sensors	M12 sensors	M18 sensors	M30 sensors
Description	Mounting bracket	Mounting bracket	Mounting bracket	Mounting bracket

Brackets straight



Steel, galvanized	AMB8-S	AMB12-S	AMB18-S	AMB30-S
Stainless steel AISI316L	-	AMB12-S316L	AMB18-S316L	-
Used for	M8 sensors	M12 sensors	M18 sensors	M30 sensors
Description	Mounting bracket	Mounting bracket	Mounting bracket	Mounting bracket

General accessories



Dimensions (mm)	-	65 x 27 x 130
Used for	Cylindrical 4 - 30 mm sensor	Testing sensor
Item number	AMB4-30	ST-03
Description	Universal sensor mounting bracket	Sensor tester for: NAMUR and 2-, 3- or 4-wire DC NPN/PNP and NO/NC with LED and Buzzer

Wind sensors

Wind vane

Types

DWS-D



Dimensions (mm)

DWS-D-DAC13: 207 x 174
DWS-D-DDC13: 183 x 145

Function

Wind direction

Wind vane references

Wind indication

DWS-D-DAC13: 0° and 90° intervals
DWS-D-DDC13: ±7° and left/right

General specifications

Built-in heater

Yes

Electrical connections

13 m, shielded grey PVC, 8 x 0.25 mm²

Rated operating voltage

12 - 24 VDC

Voltage drop

Typ. 4.9 VDC

Protection: reverse polarity (R),
transients (T)

R, T

High ESD protection

Yes

Operating temperature

-20°C to 60°C

Ambient humidity

0 to 100% RH

Climatic protection

Against high humidity, salt and dust

Degree of protection

IP54

Signal output

NPN/PNP square wave 12.5 mA ± 2 mA

Mounting position

Vertical with M28 thread

Housing material

Body: black PVC
Rotor: stainless steel

Approvals/Marks

CE

Wind sensors

Cup anemometer

Types

DWS-V



Dimensions (mm)	DWS-V-D....: 183 x 145 DWS-V-AGP: 175 x 145
-----------------	--

Function	Wind speed
----------	------------

Cup anemometer references

Air velocity	DWS-V-DAC13: 1.5 to 30 m/s DWS-V-DBC05: 1.5 to 30 m/s DWS-V-AGP: 2 to 50 m/s
--------------	---

General specifications

Built-in heater	DWS-V-DAC13: Yes DWS-V-DBC05: No DWS-V-AGP: Yes
Electrical connections	DWS-V-DAC13: 13 m, shielded grey PVC, 6 x 0.25 mm ² DWS-V-DBC05: 5 m, unshielded grey PVC, 4 x 0.25 mm ² DWS-V-AGP: Plug M16, 7-pole
Rated operating voltage	DWS-V-DAC13: 12 - 24 VDC DWS-V-DBC05: 12 - 24 VDC DWS-V-AGP: 20 - 24 VDC
Voltage drop	DWS-V-DAC13: Typ. 4.9 VDC DWS-V-DBC05: Typ. 4.9 VDC
Protection: reverse polarity (R), transients (T)	R, T
High ESD protection	Yes
Operating temperature	DWS-V-DAC13: -20°C to 60°C DWS-V-DBC05: 0°C to 60°C DWS-V-AGP: -20°C to 60°C
Ambient humidity	0 to 100% RH
Climatic protection	Against high humidity, salt and dust
Degree of protection	IP54
Signal output	DWS-V-DAC13: NPN/PNP square wave 12.5 mA ± 2 mA DWS-V-DBC05: NPN/PNP square wave 12.5 mA ± 2 mA DWS-V-AGP: 4-20 mA
Mounting position	Vertical with M28 thread
Housing material	Body: black PVC Rotor: stainless steel
Approvals/Marks	CE



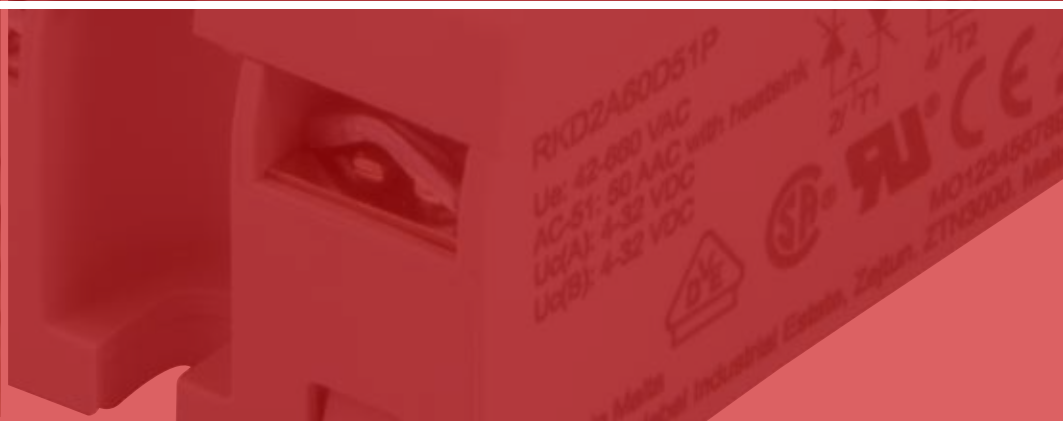

Switches



Solid state relays	140
Solid state relays accessories	177
Soft starters	182
Variable frequency drives	187
Electromechanical relays	189
Sockets for electromechanical relays	194
Switching power supplies	195



Solid state relays PCB type, 1-phase

	AC output		DC output
Types	RP1A - RP1B 3/5/5.5 AAC	RP..10 10 AAC	RP1D 1/4/8 ADC
PCB mounting SSRs, AC and DC operating. Rated isolation voltage ≥ 4000 Vrms.			
Dimensions HxWxD (mm)	25.4 x 43 x 10.5	37 x 43 x 22	25.4 x 43 x 10.5
Features	Standard AC switching SSR	With integral heatsink	DC switching SSR
Input specifications			
Control input range	3-32 VDC [RP1A23..] 3-32 VDC [RP1A40..] 4-32 VDC [RP1A48..] 16-32 VAC [RP1A23A6]	3-32 VDC [RP1A23..] 4-32 VDC [RP1A40..] 4-32 VDC [RP1A48..]	4.5 - 32 VDC
Max. input current	10 mA	10 mA	15 mA
Output specifications			
Rated operational current			DC1: 1/4/8 ADC
AC 51 @ Ta=25°C	3 A [RP1...3] 5 A [RP1...5] 5.5 A [RP1...6]	10 A	
AC 53a @ Ta=25°C	2 A [RP1...3] 3 A [RP1...5] 5 A [RP1...6]	7 A	
Min. operational current	20 mA	10 mA	1 mADC
Non rep. surge current (t=20 ms)	65 Ap [RP1...3] 80 Ap [RP1...5] 250 Ap [RP1...6]	250 AP	
Off-state leakage current	≤ 1 mA	≤ 3 mA	0.01 mADC
I ² t for fusing (t=10 ms)	20 A ² s [RP1...3] 50 A ² s [RP1...5] 340 A ² s [RP1...6]	340 A2s	
Critical dV/dt off-state	250 V/ μ s [RP1...3] 500 V/ μ s [RP1...5] 500 V/ μ s [RP1...6]	1000 V/ μ s	
General specifications			
Operational voltage range	12-265 Vrms [RP1A23..] 20-440 Vrms [RP1A40..] 20-530 Vrms [RP1A48..]	12-265 Vrms [RP1A23..] 20-440 Vrms [RP1A40..] 20-530 Vrms [RP1A48..]	1- 60 VDC [RP1D060...] 1 - 350 VDC [RP1D350...]
Blocking voltage	650 Vp [RP1A23..] 850 Vp [RP1A40..] 1000 Vp [RP1A48..]	650 Vp [RP1A23..] 850 Vp [RP1A40..] 1000 Vp [RP1A48..]	
Power factor	0.5	0.5	
Operating temperature	-20°C to +70°C	-30°C to +80°C	-20°C to +80°C
Terminals	4 pins x \varnothing 0.1 mm	4 pins x \varnothing 0.1 mm	4 pins x \varnothing 0.1 mm
Approvals/Marks	CE - UR - cUR - EAC - VDE	CE - UR - cUR - EAC	CE - UR - cUR - EAC
References			
	3 A	10 A	1 A
	RP1A23D3	RP1A23D10	RP1D350D1
	RP1A40D3	RP1A40D10	
	RP1A48D3	RP1A48D10	4 A
	5 A		RP1D060D4
	RP1A23D5		
	RP1A40D5		8 A
	RP1A48D5		RP1D060D8
	5.5 A		
	RP1A23D6		
	RP1A23A6		
	RP1A40D6		
	RP1A48D6		

* Other options available on request: Instant-on switching (RP1B..), see Accessories for DIN-rail adaptor.
CARLO GAVAZZI Automation Components. Specifications are subject to change without notice. Illustrations are for example only.

Solid state relays, 1-phase

Slimline - AC output

Types	RGS1A..KKE 25/50/75/90 AAC	RGS1A..KGE 50/90 AAC	RGS1A..MKE 25/50/90 AAC
Single-phase, chassis mounting with LED for control status indication, IP20 protection, 45-65 Hz operating frequency, ≥4000 VACrms isolation voltage, 100 kArms short circuit current rating, certified motor ratings.			
Dimensions HxWxD (mm)	90 x 17.8 x 50.6	90 x 17.8 x 50.6	90 x 17.8 x 63.6
Features	17.8 mm wide solid state relay with integrated varistor on output, AC or DC control range, screw terminals with captivated clamp for power and control connections, E-type layout	17.8 mm wide solid state relay with integrated varistor on output, AC or DC control range, box clamp for power connections (up to 25 mm ² /AWG3), screw for control connections, E-type layout	17.8 mm wide solid state relay with integrated varistor on output, AC or DC control range, screw terminals with captivated clamp for power connections and pluggable spring for control, E-type layout

Input specifications

Control input range	3-32 VDC [RG.23D.] / 4-32 VDC [RG.60D.] 20-275 VAC, 24-190 VDC [RG..A.]	4-32 VDC [RG..D.] 20-275 VAC, 24-190 VDC [RG..A..]	3-32 VDC [RG. 23D.], 4-32 VDC [RG..60D..] 20-275 VAC, 24-190 VDC [RG..A..]
Max. input current	11 mA DC [RG..D.] 30 mA AC [RG..A.]	11 mA DC [RG..D.] 30 mA AC [RG..A..]	11 mA DC [RG..D.] 30 mA AC [RG..A..]

Output specifications

Rated operational current AC-51 @ Ta=40°C	25 AAC [RG..25] / 50 AAC [RG..50/51] 75 AAC [RG..75] / 90 AAC [RG..90/91/92]	50 AAC [RG..50] 90 AAC [RG..92]	25 AAC [RG..25] / 50 AAC [RG..50] 90 AAC [RG..90/92]
AC-53a @ Ta=40°C	5 AAC [RG..25] / 10 AAC [RG..50/51] 14.8 AAC [RG..75] / 18 AAC [RG..90/91/92]	10 AAC [RG..50] 18 AAC [RG..92]	5 AAC [RG..25] / 10 AAC [RG..50] 18 AAC [RG..90/92]
Min. operational current	150 mA AC [RG..25] / 250 mA AC [RG..50/51] 400 mA AC [RG..75] / 500 mA AC [RG..90/91/92]	250 mA AC [RG..50] 500 mA AC [RG..92]	150 mA AC [RG..25] / 250 mA AC [RG..50] 500 mA AC [RG..90/92]
Non rep. surge current (t=10 ms)	325 Ap [RG..25] / 600 Ap [RG..50/51] 800 Ap [RG..75] / 1150 Ap [RG..90/91] 1900 Ap [RGS..92]	600 Ap [RG..50] 1900 Ap [RG..92]	325 Ap [RG..25] / 600 Ap [RG..50] 1150 Ap [RG..90] / 1900 Ap [RG..92]
Max. Off-state leak current	3 mA AC	3 mA AC	3 mA AC
I ² t for fusing (t=10 ms)	525 A ² s [RG..25] / 1800 A ² s [RG..50/51] 3200 A ² s [RG..75] / 6600 A ² s [RG..90/91] 18000 A ² s [RGS..92]	1800 A ² s [RG..50] 18000 A ² s [RG..92]	525 A ² s [RG..25] / 1800 A ² s [RG..50] 6600 A ² s [RG..90] / 18000 A ² s [RG..92]
Critical dV/dt (@ Tj init=40°C)	1000 V/μs	1000 V/μs	1000 V/μs

General specifications

Operational voltage range	24-240 VAC +10% [RG.23..] 42-600 VAC +10% [RG.60...] 42-690 VAC + 10% [RG..69..]*	42-600 VAC +10%	24-240 VAC +10% [RG..23..] 42-600 VAC +10% [RG..60..]
Blocking voltage	800 Vp [RG..23..] 1200 Vp [RG..60..] 1600 Vp [RG..60..51/91]	1200 Vp	800 Vp [RG..23..] 1200 Vp [RG..60..]
Power factor	≥ 0.5 at rated voltage	≥ 0.5 at rated voltage	≥ 0.5 at rated voltage
Operating temperature	-40°C to 80°C	-40°C to +80°C	-40°C to +80°C
Approvals/Marks	CE - cURus - CSA - EAC - VDE	CE - cURus - CSA - EAC - VDE	CE - cURus - CSA - EAC - VDE

References

230 VAC, 800 Vp	25 AAC: RGS1A23X25KKE	25 AAC: RGS1A23X25MKE
	50 AAC: RGS1A23X50KKE	50 AAC: RGS1A23X50MKE
600 VAC, 1200 Vp	25 AAC: RGS1A60X25KKE	25 AAC: RGS1A60X25MKE
	50 AAC: RGS1A60X50KKE	50 AAC: RGS1A60X50KGE
	75 AAC: RGS1A60X75KKE	50 AAC: RGS1A60X50MKE
	90 AAC: RGS1A60X90KKE	90 AAC: RGS1A60X90MKE
600 VAC, 1600 Vp	90 AAC: RGS1A60X92KKE	90 AAC: RGS1A60X92MKE
	50 AAC: RGS1A60X51KKE	
	90 AAC: RGS1A60X91KKE	
690 VAC, 1600 Vp	90 AAC: RGS1A69X91KKE*	

X must be replaced with D for DC control 3-32 VDC, 4-32 VDC (for 600 VAC versions)

X must be replaced with A for AC control 20-275 VAC, 24-190 VDC



RGS1B.. models for Instant On (Random) switching are available on request

*690 VAC variants are CE marked only and do not include a varistor across the output

CARLO GAVAZZI Automation Components. Specifications are subject to change without notice. Illustrations are for example only.

Solid state relays, 1-phase

Slimline - AC output

Types	RGS1A..MGE 50/90 AAC	RGS1A..KGU 30 AAC	RGS1A..DIN 10/12 AAC
Single-phase, chassis mounting with LED for control status indication, IP20 protection, 45-65 Hz operating frequency, ≥ 4000 VACrms isolation voltage, 100 kArms short circuit current rating, certified motor ratings.			
Dimensions HxWxD (mm)	90 x 17.8 x 63.6	90 x 17.8 x 50.6	106 x 17.8 x 65
Features	17.8 mm wide solid state relay with integrated varistor on output, AC or DC control range, box clamps for power connections (25 mm ² / AWG3) and pluggable spring for control, E-type layout	17.8 mm wide solid state relay with integrated varistor on output, AC or DC control range, box clamps for power and control connections, U-type layout	17.8 mm wide solid state relay mounted on DIN mountable module

Input specifications

Control input range	4-32 VDC [RG..D..] 20-275 VAC, 24-190 VDC [RG..A..]	4-32 VDC [RG..D..] 20-275 VAC, 24-190 VDC [RG..A..]	3-32 VDC [RG..23D..] 4-32 VDC [RG..60D..] 20-275 VAC, 24-190 VDC [RG..A..]
Max. input current	11 mA DC [RG..D..] 30 mA AC [RG..A..]	11 mA DC [RG..D..] 30 mA AC [RG..A..]	11 mA DC [RG..D..] 30 mA AC [RG..A..]

Output specifications

Rated operational current AC-51 @ Ta=40°C	50 AAC [RG..50] 90 AAC [RG..92]	30 AAC	10 AAC [RG..20/25..DIN] 12 AAC [RG..50/90..DIN]
AC-53a @ Ta=40°C	10 AAC [RG..50] 18 AAC [RG..92]	8 AAC	5 AAC [RG..20/25..DIN] 5 AAC [RG..50/90..DIN]
Min. operational current	250 mA AC [RG..50] 500 mA AC [RG..92]	250 mA AC	150 mA AC [RG..20/25..DIN] 250 mA AC [RG..50..DIN] 400 mA AC [RG..90..DIN]
Non rep. surge current (t=10 ms)	600 A _p [RG..50] 1900 A _p [RG..92]	600 A _p	325 A _p [RG..20/25..DIN] 600 A _p [RG..50..DIN] 1150 A _p [RG..90..DIN]
Max. Off-state leak current	3 mA AC	3 mA AC	3 mA AC
I ² t for fusing (t=10 ms)	1800 A ² s [RG..50] 18000 A ² s [RG..92]	1800 A ² s	525 A ² s [RG..20/25..DIN] 1800 A ² s [RG..50..DIN] 6600 A ² s [RG..90..DIN]
Critical dV/dt (@ T _j init=40°C)	1000 V/μs	1000 V/μs	1000 V/μs

General specifications

Operational voltage range	42-600 VAC +10%	42-600 VAC +10%	24-240 VAC +10% [RG..23..] 42-600 VAC +10% [RG..60..]
Blocking voltage	1200 V _p	1200 V _p	800 V _p [RG..23..] 1200 V _p [RG..60..]
Power factor	≥ 0.5 at rated voltage	≥ 0.5 at rated voltage	≥ 0.5 at rated voltage
Operating temperature	-40°C to +80°C	-40°C to +80°C	-40°C to +80°C
Approvals/Marks	CE - cURus - CSA - EAC - VDE	CE - cURus - CSA - EAC - VDE	CE - cURus - CSA - EAC - VDE

References



230 VAC, 800 V _p , E-type			10 AAC: RGS1A23X25KKEDIN 12 AAC: RGS1A23X50KKEDIN
600 VAC, 1200 V _p , E-type	50 AAC: RGS1A60X50MGE 90 AAC: RGS1A60X92MGE		10 AAC: RGS1A60X25KKEDIN 12 AAC: RGS1A60X50KKEDIN 12 AAC: RGS1A60D90KKEDIN
600 VAC, 1200 V _p , U-type		30 AAC: RGS1A60X30KGU	10 AAC: RGS1A60D20KGDIN

X must be replaced with D for DC control 3-32 VDC, 4-32 VDC (for 600 VAC versions)
X must be replaced with A for AC control 20-275 VAC, 24-190 VDC
RGS1B.. models for Instant On (Random) switching are available on request

Solid state relays, 1-phase

Slimline - DC output

Slimline - AC output, Integrated monitoring

Types	RGSD1..KKE 15/25 ADC	RGSA1..KEM 25/50/90 AAC	RGSA1..GEM 90 AAC
Single-phase, chassis mounting industrial relays with LED for control status indication and IP20 protection, rated isolation voltage ≥ 4000 Vrms, 100 kArms short circuit current rating for AC switching versions.			
Dimensions HxWxD (mm)	90 x 17.8 x 50.6	90 x 17.8 x 82	90 x 17.8 x 82
Features	17.8 mm wide solid state relay with IGBT output, integrated free wheeling diode, DC control voltage, screw terminals with captivated clamp, E-type layout	17.8 mm wide solid state relay, integrated monitoring for SSR and load malfunction, integrated varistor, DC control and supply, transistor output for remote alarm signalling	17.8 mm wide solid state relay, integrated monitoring for SSR and load malfunction, integrated varistor, DC control and supply, transistor output for remote alarm signalling
Input specifications			
Control input range	4.5-32 VDC	4-32 VDC	4-32 VDC
Max. input current		0.5 mADC at 24 VDC	0.5 mADC at 24 VDC
Supply voltage		19.2 - 28.8 VDC	19.2 - 28.8 VDC
Max. supply current	13.7 mADC	40 mA	40 mA
Alarm specifications			
Output type		Transistor, NC, NO max. 35 VDC/100 mA	Transistor, NC, NO max. 35 VDC/100 mA
Alarm indication		Mains loss, load loss, SSR open and short cct, SSR internal error, supply out of range	Mains loss, load loss, SSR open and short cct, SSR internal error, supply out of range
Output specifications			
Rated operational current AC-51 @ $T_a=40^\circ\text{C}$		25 AAC [RGSA1..25] 50 AAC [RGSA1..50] 90 AAC [RGSA1..92]	90 AAC
DC Rated operational current	15 ADC [RGSD1..15.] 25 ADC [RGSD1..25.]		
Minimum operational current	20 mA	150 mAAC [RGSA1..25] 250 mAAC [RGSA1..50] 500 mAAC [RGSA1..92]	500 mAAC
Non rep. surge current (I_{tsm}) ($t=10$ ms)	200 ADC [10 μ s]	325 Ap [RGSA1..25] 600 Ap [RGSA1..50] 1900 Ap [RGSA1..92]	1900 Ap
Max. Off-state leak current	1.5 mADC	5 mAAC	5 mAAC
I^2t for fusing ($t=10$ ms)		525 A ² s [RGSA1..25] 1800 A ² s [RGSA1..50] 18000 A ² s [RGSA1..92]	18000 A ² s
Critical dV/dt (@ T_j init= 40°C)		1000 V/ μ s	1000 V/ μ s
General specifications			
Operational voltage range	24-1000 VDC [CE] 24-600 VDC [UL508]	42-265 VAC [RGSA1A23..] 150-660 VAC [RGSA1A60..]	150-660 VAC
Blocking voltage	1200 VDC	800 Vp [RGSA1A23..] 1200 Vp [RGSA1A60..]	1200 Vp
Power factor		≥ 0.9 at rated voltage	≥ 0.9 at rated voltage
Operating temperature	-40°C to +80°C	-20°C to +65°C	-20°C to +65°C
Approvals/Marks	CE - cURus - CSA - EAC	CE - cURus - CSA - EAC	CE - cURus - CSA - EAC
References			
1000 VDC	15 ADC: RGSD1000D15KKE 25 ADC: RGSD1000D25KKE		
230 VAC, 800 Vp, 525 A ² s, Screw		25 AAC: RGSA1A23D25KEM	
600 VAC, 1200 Vp, 525 A ² s, Screw		25 AAC: RGSA1A60D25KEM	
600 VAC, 1200 Vp, 1800 A ² s, Screw		50 AAC: RGSA1A60D50KEM	
600 VAC, 1200 Vp, 18000 A ² s, Screw		90 AAC: RGSA1A60D92KEM	
600 VAC, 1200 Vp, 18000 A ² s, Box			90 AAC: RGSA1A60D92GEM

KK = screws for control terminals, screws for power terminals
 GK = box clamps for control terminals, screws for power terminals
 GG = box clamps for control terminals, box clamps for power terminals

CARLO GAVAZZI Automation Components. Specifications are subject to change without notice. Illustrations are for example only.

Solid state relays, 1-phase

Slimline - AC output, integrated current measurement

Types	RGS1S..EP 30/90 AAC	RGS1S..UP 65 AAC
-------	------------------------	---------------------

Single-phase, chassis mounting industrial relays with LED for control status indication and IP20 protection, rated isolation voltage ≥ 4000 Vrms, 100 kArms short circuit current rating for AC switching versions.



Dimensions HxWxD (mm)	90 x 22.5 x 78	90 x 35.6 x 78
-----------------------	----------------	----------------

Features	22.5 mm wide solid-state relay with thyristor output, integrated varistor, DC control, local or remote TEACH, detection of partial load failure (1/6), SSR and load malfunction, SSR overheat protection.	35 mm wide solid-state relay with thyristor output, integrated varistor, DC control, local or remote TEACH, detection of partial load failure (1/6), SSR and load malfunction, SSR overheat protection.
----------	---	---

Input specifications

Control input range	4-32 VDC	4-32 VDC
Max. input current	10 mA _{DC} at 24 VDC	10 mA _{DC} at 24 VDC
Supply voltage	24 VDC -15%, +20%	24 VDC -15%, +20%
Max. supply current	50 mA _{DC}	50 mA _{DC}

Alarm specifications

Output type	NC PNP open collector max. 35 VDC / 50 mA	NC PNP open collector max. 35 VDC / 50 mA
Alarm indication	Red LED (flash rate)	Red LED (flash rate)

Output specifications

Rated operational current AC-51 @ Ta=40°C	30 AAC [RGS1S..30] 90 AAC [RGS1S..92]	65 AAC
Minimum TEACH / operational current	1.2 AAC [RGS1S..30] 5 AAC [RGS1S..92]	5 AAC
Minimum partial load current	0.2 AAC [RGS1S..30] 0.83 AAC [RGS1S..92]	0.83 AAC
Detectable partial load failure	> 16.67% from current setpoint	> 16.67% from current setpoint
Non rep. surge current (I _{tsm}) (t=10 ms)	600 A _p [RGS1S..30] 1900 A _p [RGS1S..92]	1900 A _p
Max. Off-state leak current	3 mA _{AC}	3 mA _{AC}
I ² t for fusing (t=10 ms)	1800 A ² s [RGS1S..30] 18000 A ² s [RGS1S..92]	18000 A ² s
Critical dV/dt (@ T _j init=40°C)	1000 V/μs	1000 V/μs

General specifications





Operational voltage range	42-600 VAC +10%	42-600 VAC +10%
Blocking voltage	1200 V _p	1200 V _p
Power factor	≥ 0.9 at rated voltage	≥ 0.9 at rated voltage
Operating temperature	-25°C to +70°C	-25°C to +70°C
Approvals/Marks	CE - cURus - CSA - EAC	CE - cURus - CSA - EAC

References

600 VAC, 1800 A ² s, E-type	30 AAC: RGS1S60D30GKEP	
600 VAC, 18000 A ² s, E-type	90 AAC: RGS1S60D92GGEP	
600 VAC, 18000 A ² s, U-type		65 AAC: RGS1S60D61GGUP

GK = box clamps for control terminals, screws for power terminals
GG = box clamps for control terminals, box clamps for power terminals

Solid state relays, 1-phase



	Slimline - Soft start switching		Slimline - Proportional controllers	
Types	RGS1P..K.. 50 AAC	RGS1P..K.. 90 AAC	RGS1P..AA.. / V.. 50 AAC	RGS1P..AA.. / V.. 90 AAC
Single-phase, chassis mounting industrial relays with integrated overvoltage protection, LED for control and load status indication, IP20 protection, rated isolation voltage ≥ 4000 Vrms, 100 kArms short circuit current rating.				
Dimensions HxWxD (mm)	90 x 35.8 x 51	90 x 35.8 x 51	90 x 35.8 x 51	90 x 35.8 x 51
Features	DC control input solid state relay with soft starting feature for short wave infrared heaters	DC control input solid state relay with soft starting feature for short wave infrared heaters	Analogue input (current or voltage), selectable modes for output switching - phase angle, full cycle distributed firing, advanced full cycle and soft starting	Analogue input (current or voltage), selectable modes for output switching - phase angle, full cycle distributed firing, advanced full cycle and soft starting
Supply specifications				
Supply voltage	24 VDC -15%, +20% 24 VAC -15%, +15%	24 VDC -15%, +20% 24 VAC -15%, +15%	24 VDC -15%, +20% [RG..V..ED] 24 VAC -15%, +15% [RG..V..ED] 90-250 VAC [RG..V..EA]	24 VDC -15%, +20% [RG..V..ED] 24 VAC -15%, +15% [RG..V..ED] 90-250 VAC [RG..V..EA]
Max. supply current	30 mA	30 mA	30 mA [RG..V..ED] 14 mA [RG..V..EA]	30 mA [RG..V..ED] 14 mA [RG..V..EA]
Control specifications				
Control input range	19.2 - 28.8 VDC	19.2 - 28.8 VDC	4-20 mA [RG..AA..] 0-10 V, 0-5 V, 1-5 V, POT [RG..V..]	4-20 mA [RG..AA..] 0-10 V, 0-5 V, 1-5 V, POT [RG..V..]
Input impedance	100 k Ω	100 k Ω	500 Ω [RG..AA..] 100 k Ω [RG..V..]	500 Ω [RG..AA..] 100 k Ω [RG..V..]
Output specifications				
Rated operational current AC-51 @ 40°C	50 AAC	90 AAC	50 AAC	90 AAC
Minimum operational current	250 mAAC	500 mAAC	250 mAAC	500 mAAC
Non rep. surge current (I _{sm}) (t=10 ms)	600 Ap	1900 Ap	600 Ap	1900 Ap
I ² t for fusing (t=10 ms)	1800 A ² s	18000 A ² s	1800 A ² s	18000 A ² s
Max. Off-state leakage current	5 mAAC	5 mAAC	5 mAAC	5 mAAC
Critical dV/dt (@ T _j init=40°C)	1000 V/ μ s	1000 V/ μ s	1000 V/ μ s	1000 V/ μ s
General specifications				
Operational voltage range	85 - 265 VAC [RGS1P23..] 190 - 550 VAC [RGS1P48..] 410 - 660 VAC [RGS1P60..]	85 - 265 VAC [RGS1P23..] 190 - 550 VAC [RGS1P48..] 410 - 660 VAC [RGS1P60..]	85 - 265 VAC [RGS1P23..] 190 - 550 VAC [RGS1P48..] 410 - 660 VAC [RGS1P60..]	85 - 265 VAC [RGS1P23..] 190 - 550 VAC [RGS1P48..] 410 - 660 VAC [RGS1P60..]
Blocking voltage	800 V _P [RGS1P23..] 1200 V _P [RGS1P48..] 1200 V _P [RGS1P60..]	800 V _P [RGS1P23..] 1200 V _P [RGS1P48..] 1200 V _P [RGS1P60..]	800 V _P [RGS1P23..] 1200 V _P [RGS1P48..] 1200 V _P [RGS1P60..]	800 V _P [RGS1P23..] 1200 V _P [RGS1P48..] 1200 V _P [RGS1P60..]
Power factor	> 0.7	> 0.7	> 0.7	> 0.7
Terminals	Screw with captive clamp	Box clamp	Screw with captive clamp	Box clamp
Operating temperature	-40°C to +70°C	-40°C to +70°C	-40°C to +70°C	-40°C to +70°C
Approvals/Marks	CE - cURus - CSA - EAC	CE - cURus - CSA - EAC	CE - cURus - CSA - EAC	CE - cURus - CSA - EAC
References				
External supply 24 VDC/AC				
Operational output 85 - 265 VAC	RGS1P23K50ED	RGS1P23K92ED		
Operational output 190 - 550 VAC	RGS1P48K50ED	RGS1P48K92ED		
Operational output 410 - 660 VAC	RGS1P60K50ED	RGS1P60K92ED		
Control input				
4-20 mA			RGS1PxxAA50E	RGS1PxxAA92E
0-10 VDC, 0-5 VDC, 1-5 VDC, POT				
External supply 24 VDC/AC			RGS1PxxV50ED	RGS1PxxV92ED
External supply 90-250 VAC			RGS1PxxV50EA	RGS1PxxV92EA

xx = 23 for operational voltage range 85 - 265 VAC
 xx = 48 for operational voltage range 190 - 550 VAC
 xx = 60 for operational voltage range 410 - 660 VAC

CARLO GAVAZZI Automation Components. Specifications are subject to change without notice. Illustrations are for example only.

Solid state relays, 1-phase

Industrial housing - AC output

Types	RF1A 25 AAC	RS1A 10/25/40 AAC	RAM1A..G 25/50/100/125 AAC
Single-phase, chassis mounting, industrial relays with LED status indication and IP20 protection. AC operating frequency range 45-65 Hz. Rated isolation voltage ≥ 4000 Vrms.			
Dimensions HxWxD (mm)	36 x 21 x 24	58.2 x 44.8 x 28.8	58.2 x 44.8 x 28.8
Features	Zero Cross or Instant ON, Built-in transil, VDE, Glow wire acc. to IEC/EN 60335-1	Zero Cross, Ideal for Ohmic loads	Zero Cross, Built-in varistor, VDE, Glow wire acc. to IEC/EN 60335-1

Input specifications

Control input range	4.25 - 9 VDC [RF1A..L] 9 - 18 VDC [RF1A..M] 18 - 28.8 VDC [RF1A..D]	3-32 VDC [RS1A23D] 4-32 VDC [RS1A....D] 18-36 VAC/DC [RS1A...LA] 80-130 VAC [RS1A..A1-] 200-260 VAC [RS1A..A2-] 360-440 VAC [RS1A..A4-]	3-32 VDC [RAM1A23D..] 4-32 VDC [RAM1A60D..] 20-280 VAC / 22-48 VDC [RAM1A..A.]
Max. input current	15 mA [RF1A..L] 12 mA [RF1A..M] 12.5 mA [RF1A..D]	12 mA [RS1A..D] 15 mA [RS1A..LA] 13 mA [RS1A...A1- /A2- /A4-]	12 mA [RAM1A..D.] 20 mA [RAM1A..A.]

Output specifications

		RS1A..10 / 25 / 40	RAM1A..25/50/51/100/125
Rated operational current			
AC 51 @ Ta=25°C	25 AAC	10 / 25 / 40 AAC	25 / 50 / 50 / 100 / 125 AAC
AC 53a @ Ta=25°C			5 / 15 / 15 / 20 / 30 AAC
Min. operational current	150 mAAC	150 / 150 / 250 mAAC	150 / 250 / 400 / 400 / 500 mAAC
Non rep. surge current (t=10 ms)	325 Ap	100 / 325 / 600 Ap	325 / 600 / 800 / 1150 / 1900 Ap
Off-state leakage current	< 3 mA	< 3 mA	< 3 mA
I ² t for fusing (t=10 ms)	525 A ² s	50 / 525 / 1800 A ² s	525 / 1800 / 3200 / 6600 / 18000 A ² s
Critical dV/dt	1000 V/μs	500 V/μs	1000 V/μs

General specifications

Operational voltage range	24 - 280 VAC	42-265 VAC [RS1A23..] 42-440 VAC [RS1A40..] 42-530 VAC [RS1A48..]	24-265 VAC [RAM1A23..] 42-660 VAC [RAM1A60..]
Blocking voltage	600Vp	650 Vp [RS1A23..] 850 Vp [RS1A40..] 1200 Vp [RS1A48..]	650 Vp [RAM1A23..] 1200 Vp [RAM1A60..]
Power factor	≥ 0.9	≥ 0.95	≥ 0.5
Operating temperature	-30°C to +80°C	-20°C to +70°C	-40°C to +80°C
Terminals	FASTONS	Screw type with clamp	Screw type with clamp
Approvals/Marks	CE - UR - CSA - VDE - EAC	CE - UR - CSA - EAC	CE - UR - CSA - CCC - VDE - EAC

References

	25 AAC	10 / 25 / 40 AAC	25 / 50 / 100 / 125 AAC
230 VAC	RF1A23L25 RF1A23M25 RF1A23D25	RS1A23X10 (X = D, LA only) RS1A23X25 RS1A23X40	RAM1A23DYYG RAM1A23AYYG
400 VAC		RS1A40X10 (X = D, LA only) RS1A40X25 RS1A40X40	
480 VAC		RS1A48X10 (X = D, LA only) RS1A48X25 (X = D, LA only) RS1A48X40 (X = D, LA only)	
600 VAC			RAM1A60DYYG RAM1A60AYYG



RF1B.., RAM1B.. Instant On switching versions available on request.

X = D for DC control = 3-32 VDC (RS1A23..), 4-32 VDC (RS1A40.., RS1A48..)
X = LA for AC control = 18-36 VAC/DC
X = A1- for AC control = 80-130 VAC (not available for RS1A40..)

X = A2- for AC control = 200-260 VAC
X = A4- for AC control = 360-440 VAC
YY = 25 for 25 AAC
YY = 50 for 50 AAC

YY = 51 for 50 AAC high I²t (RAM1A60..G only)
YY = 100 for 100 AAC (not available for RAM1A23..G)
YY = 125 for 125 AAC (not available for RAM1A23..G)

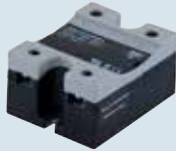
Solid state relays, 1-phase

	Industrial housing - AC output	Industrial housing - peak switching	Industrial housing - phase angle switching
Types	RM1A 25/50/75/100 AAC	RM1C 25/50/75/100 AAC	RM1E 25/50/100/125 AAC
Single-phase, chassis mounting, industrial relays with LED status indication and IP20 protection AC operating frequency range 45-65 Hz. Rated isolation voltage ≥ 4000 Vrms.			
Dimensions HxWxD (mm)	58.2 x 44.8 x 28.8	58.2 x 44.8 x 28.8	58.2 x 44.8 x 28.8
Features	Zero Cross or Instant ON, Built-in varistor	Ideal for transformers	Analogue phase-angle control

Input specifications

Control input range	3-32 VDC [RM1A23D.] 4-32 VDC [RM1A60D.] 20-280 VAC / 22-48 VDC [RM1A..A.] 4.25-36 VDC / 4.25-27 VAC [RM1A..M.]	4.25-32 VDC	4-20 mA [RM1E..AA.] 0-10 VDC [RM1E..V..]
Max. input current	12 mA [RM1A..D.] 20 mA [RM1A..A.] 18 mA [RM1A..M.]	18 mA	0.15 mA [RM1E..V..]
Supply voltage range			24 VDC [RM1E..V..]
Max. supply input current			20 mA [RM1E..V..]

Output specifications

	RM1A..25 / 50 / 75 / 100	RM1C..25 / 50 / 75 / 100	RM1E..25 / 50 / 100 / 125
Rated operational current			
AC 51 @ $T_a=25^\circ\text{C}$	25 / 50 / 75 / 100 AAC	25 / 50 / 75 / 100 AAC	25 / 50 / 100 / 125 AAC
AC 53a @ $T_a=25^\circ\text{C}$	5 / 15 / 20 / 30 AAC		5 / 15 / 20 / 30 AAC
AC 56a @ $T_a=25^\circ\text{C}$		10 / 20 / 25 / 30 AAC	
Min. operational current	150 / 250 / 400 / 500 mAAC	150 / 250 / 400 / 500 mAAC	150 / 250 / 400 / 500 mAAC
Non rep. surge current (t=10 ms)	325 / 600 / 1150 / 1900 A _p	325 / 600 / 1150 / 1900 A _p	325 / 600 / 1150 / 1900 A _p
Off-state leakage current	< 3 mA	< 3 mA	< 3 mA
I ² t for fusing (t=10 ms)	525 / 1800 / 6600 / 18000 A ² s	525 / 1800 / 6600 / 18000 A ² s	525 / 1800 / 6600 / 18000 A ² s

General specifications

Operational voltage range	24-265 VAC [RM1A23..] 42-440 VAC [RM1A40..] 42-530 VAC [RM1A48..] 42-660 VAC [RM1A60..]	100-440 VAC [RM1C40D.] 340-660 VAC [RM1C60D.]	90-280 VAC [RM1E23AA..] 90-265 VAC [RM1E23V..] 340-460 VAC [RM1E40AA..] 200-550 VAC [RM1E48AA/V..] 410-660 VAC [RM1E60AA/V..]
Blocking voltage	650 V _p [RM1A23..] 850 V _p [RM1A40..] 1200 V _p [RM1A48..] 1400 V _p [RM1A60..]	850 V _p [RM1C40D..] 1400 V _p [RM1C60D..]	650 V _p [RM1E23..] 850 V _p [RM1E40..] 1200 V _p [RM1E48..] 1400 V _p [RM1E60..]
Power factor	≥ 0.5	≥ 0.5	≥ 0.75
Operating temperature	-20°C to +70°C	-30°C to +80°C	-20°C to +70°C
Terminals	Screw type with clamp	Screw type with clamp	Screw type with clamp
Approvals/Marks	CE - UR - CSA - CCC - EAC	CE - UR - CSA - EAC	CE - UR - CSA - EAC



1-phase references:

	25 / 50 / 75 / 100 AAC	25 / 50 / 75 / 100 AAC	25 / 50 / 100 / 125 AAC
230 Vrms	RM1A23XY		RM1E23X25 (X = AA or V)
			RM1E23X50 (X = AA or V)
			RM1E23X100 (X = AA or V)
			RM1E23X125 (X = AA or V)
400 Vrms	RM1A40XY	RM1C40D25 RM1C40D50 RM1C40D75	RM1E40AA25
			RM1E40AA50
			RM1E40AA100
480 Vrms	RM1A48XY		RM1E48X25 (X = AA or V)
			RM1E48X50 (X = AA or V)
			RM1E48X100 (X = AA or V)
			RM1E48X125 (X = AA or V)
600 Vrms	RM1A60XY	RM1C60D25 RM1C60D50 RM1C60D100	RM1E60X25 (X = AA or V)
			RM1E60X50 (X = AA or V)
			RM1E60X100 (X = AA or V)
			RM1E60X125 (X = AA or V)

RM1B.. Instant On switching versions available on request X = D for DC control = 3-32 VDC (RM1A23..), 4-32 VDC (RM1A40.., RM1A48.., RM1A60..) Y = M for low AC control = 4.25-36 VDC / 4.25-27 VAC YY = 75 for 75 AAC
YY = 25 for 25 AAC YY = 100 for 100 AAC
X = A for AC control = 20-280 VAC / 22-48 VDC YY = 50 for 50 AAC

Solid state relays, 1-phase

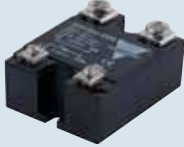
Industrial housing - AC output

Types	RA 25/50/90/110 AAC	RA Sense 25/50/110 AAC	RA Low Noise 10/25 AAC
Single-phase relays, chassis mounting, variants with special functions. 2-phase industrial relays.			
Dimensions HxWxD (mm)	58.2 x 44.8 x 28.8	58.2 x 44.8 x 28.8	58.2 x 44.8 x 28.8
Features	General purpose	Detects supply and load failure	Complies with EN55022
Input specifications			
Control input range	3-32 VDC [RA..D..] 10-90 VAC/DC [RA..LA..] 90-280 VAC/DC [RA..HA..]	7-32 VDC	3-32 VDC
Max. input current	22 mA [RA..D..] 17 mA [RA..LA..] 6.5 mA [RA..HA..]	4 mA	32 mA
Control supply		20-32 VDC (40 mA)	
Alarm output	PNP NPN	VCC - 2 VDC (100 mA) 2 VDC (100 mA)	
Output specifications			
Rated operational current			
AC 51 @ Ta=25°C	25 / 50 / 90 / 110 AAC	25 / 50 / 110 AAC	10 / 25 AAC
AC 53a @ Ta=25°C	5/15/ 20/30 AAC		
Min. operational current	20 mA	200 mArms	2 Arms
Non rep. surge current (t=10 ms)	325 Ap [RA..25.] 600 Ap [RA..50.] 1150 Ap [RA..90.] 1900 Ap [RA..110.]	325 Ap [RA..25..S] 600 Ap [RA..50..S] 1150 Ap [RA..90..S] 1900 Ap [RA..110..S]	90 Ap, t=20 ms [RA..10..L] 200 Ap, t=20 ms [RA..25..L]
Off-state leakage current	< 3 mA	< 6 mArms	< 1 mArms
I ² t for fusing (t=10 ms)	<525 A ² s [RA..25.] <1800 A ² s [RA..50.] <6600 A ² s [RA..90.] <18000 A ² s [RA..110.]	525 A ² s [RA..25..S] 1800 A ² s [RA..50..S] 6600 A ² s [RA..90..S] 18000 A ² s [RA..110..S]	120 A ² s [RA..10..L] 200 A ² s [RA..25..L]
General specifications			
Operational voltage range	24-280 Vrms [RA24.06..] 42-480 Vrms [RA44.08..] 42-530 Vrms [RA48.12..] 24-690 Vrms [RA60.16..]	60-140 Vrms [RA12..S] 170-250 Vrms [RA23..S] 150-440 Vrms [RA40..S] 180-530 Vrms [RA48..S]	180-265 Vrms [RA24..L] 340-530 Vrms [RA40..L]
Blocking voltage	<650 Vp [RA24.06..] <850 Vp [RA44.08..] <1200 Vp [RA48.12..] <1600 Vp [RA60.16..]	650 Vp [RA12..S] 650 Vp [RA23..S] 1000 Vp [RA40..S] 1200 Vp [RA48..S]	650 Vp [RA24..L] 850 Vp [RA40..L]
Power factor	≥ 0.5	≥ 0.5	1
Operating temperature	-20°C to +70°C	-20°C to +70°C	-20°C to +70°C
Terminals	Screw type with clamp	Screw / 5 way plug	Screw type with clamp
Approvals/Marks	CE - UR - CSA - EAC	CE - UR - CSA - EAC	CE - UR - CSA
References			
120 Vrms	25 / 50 / 90 / 110 AAC	25 / 50 / 110 AAC	10 / 25 AAC
230 Vrms	RA24..D.. RA24..LA.. RA24..HA..	RA12..06..S RA23..06..S	RA2410-D06L RA2425-D06L
400 Vrms	RA44..D.. RA44..LA.. RA44..HA..	RA40..10..S	RA4010-D08L RA4025-D08L
480 Vrms	RA48..D.. RA48..LA.. RA48..HA..	RA48..12..S	
600 Vrms	RA60..D..		

Solid state relays, 1 / 3-phase

Industrial housing - DC output

Industrial housing - AC output, 3 poles

Types	RM1D 10/20/50/100 ADC	RZ3A 25/55/75 AAC
Single-phase and 3-phase industrial relays		

Dimensions HxWxD (mm)	58.2 x 44.8 x 29.5	74 x 103 x 41
Features	DC switching SSR, 4 kV isolation between input and output, fast response times	3-phase switching, integrated overvoltage protection

Input specifications

Control input range	4-32 VDC [RM1D060..] 4.5 - 32 VDC [RM1D200/500..]	4-32 VDC [RZ3A..D.] 24-275 VAC [RZ3A..A.]
Max. input current	16 mA	23 mA [RZ3A..D.] 15 mA [RZ3A..A.]
Switching frequency	up to 1000 Hz	

Output specifications

Rated operational current	DC1: 10 / 20 / 50 / 100 A, 60 VDC DC1: 20 / 50 A, 200 VDC DC1: 10 A, 500 VDC	AC51: 25 / 55 / 75 AAC AC53a: 5 / 15 / 20 AAC
Min. operational current	5 mADC	150 mAAC [RZ3..25] 250 mAAC [RZ3..55] 400 mAAC [RZ3..75]
Non rep. surge current (t=10 ms)		325 Ap [RZ3A..25..] 600 Ap [RZ3A..55..] 1150 Ap [RZ3A..75..]
Off-state leakage current	0.1 mADC	< 3 mA
I ² t for fusing (t=10 ms)		525 A ² s [RZ3A..25..] 1800 A ² s [RZ3A..55..] 6600 A ² s [RZ3A..75..]

General specifications

Operational voltage range	1-60 VDC [RM1D060..] 1-200 VDC [RM1D200..] 1-500 VDC [RM1D500..]	24-440 VAC [RZ3A40.] 42-530 VAC [RZ3A48.] 42-660 VAC [RZ3A60.] 42-750 VAC [RZ3A69.]
Blocking voltage	-	<800 Vp [RZ3A40..] <1200 Vp [RZ3A48..] <1600 Vp [RZ3A60..] <1600 Vp [RZ3A69.]
Operating temperature	-20°C to +80°C	-30°C to +80°C
Terminals	Screw type with clamp	Screw type with clamp
Approvals/Marks	CE - UR - CSA - EAC	CE - UR - CSA - EAC





References

DC output voltage:		25 / 55 / 75 AAC per pole
60 VDC	10 A: RM1D060D10 20 A: RM1D060D20 50 A: RM1D060D50 100 A: RM1D060D100	
200 VDC	20 A: RM1D200D20 50 A: RM1D200D50	
500 VDC	10 A: RM1D500D10	
AC output voltage:		
400 VAC		RZ3A40DYY* RZ3A40AYY*
480 VAC		RZ3A48DYY* RZ3A48AYY*
600 VAC		RZ3A60DYY* RZ3A60AYY*
690 VAC		RZ3A69D75** RZ3A69A75**

* Add suffix 'P' for additional integrated Over Temperature Protection, ** CE only
YY = 25 for 25 AAC, YY = 55 for 55 AAC, YY = 75 for 75 AAC

Solid state relays, 2-poles





Industrial housing - AC output

Types	RA2A 25/40 AAC	RA2A..C 25/40 AAC	RKD2..C RK2..C 50/75 AAC	RKD2..P RK2..P 50/75 AAC
2-pole industrial solid state relays.				
Dimensions HxWxD (mm)	57.8 x 44.5 x 31.7	57.8 x 44.5 x 34.8	53 x 44.5 x 33	58 x 44.5 x 33 (w/o plug) 58 x 44.5 x 44 (incl. plug)
Features	Two independent poles, RA2A..M for inductive loads	Two independent poles with integrated varistor on output	2-poles with independent control [RKD2] or common control [RK2], control connection via connector pins	2-poles with independent control [RKD2] or common control [RK2], control connection via provided spring plug
Input specifications				
Control input range	4.5-32 VDC	4.5-32 VDC	4-32 VDC	4-32 VDC
Max. input current	2 x 10 mA	2x 10 mA	2 x 12 mA [RKD2..] 1 x 24 mA [RK2..]	2 x 12 mA [RKD2..] 1 x 24 mA [RK2..]
Output specifications				
Rated operational current				
AC 51 @ Ta=25°C	25 / 40 AAC per pole	25 / 40 AAC per pole	50 AAC per pole [RK..50/51] 75 AAC per pole [RK..75]	50 AAC per pole [RK..50/51] 75 AAC per pole [RK..75]
AC 53a @ Ta=25°C	5 / 15 AAC per pole [RA2A..M]		12 AAC	12 AAC
Min. operational current	150 mArms [RA2A...25] 250 mArms [RA2A...40]	150 mArms [RA2A...25C] 250 mArms [RA2A...40C]	250 mArms [RK..50] 400 mArms [RK..51/75]	250 mArms [RK..50] 400 mArms [RK..51/75]
Non rep. surge current (t=10 ms)	325 Ap [RA2A..25] 600 Ap [RA2A..40]	325 Ap [RA2A...25C] 600 Ap [RA2A...40C]	500 Ap [RK..50] 775 Ap [RK..51] 1400 Ap [RK..75]	500 Ap [RK..50] 775 Ap [RK..51] 1400 Ap [RK..75]
Off-state leakage current	<3 mArms	<3 mArms	≤3 mArms	≤3 mArms
I ² t for fusing (t=10 ms)	525 A ² s [RA2A..25] 1800 A ² s [RA2A..40]	525 A ² s [RA2A..25C] 1800 A ² s [RA2A..40C]	1500 A ² s [RK..50] 3000 A ² s [RK..51] 9800 A ² s [RK..75]	1500 A ² s [RK..50] 3000 A ² s [RK..51] 9800 A ² s [RK..75]
General specifications				
Operational voltage range	24-265 Vrms [RA2A23..] 42-530 Vrms [RA2A48..] 42-660 Vrms [RA2A60..]	24-265 Vrms [RA2A23..] 42-660 Vrms [RA2A60..]	24-265 Vrms [RK..23..] 42-660 Vrms [RK..60]	24-265 Vrms [RK..23] 42-660 Vrms [RK..60]
Blocking voltage	650 Vp [RA2A23..] 1200 Vp [RA2A48..] 1200 Vp [RA2A60..]	650 Vp [RA2A23..] 1200 Vp [RA2A60..]	600 Vp [RK..23..] 1200 Vp [RK..60..]	600 Vp [RK..23..] 1200 Vp [RK..60..]
Power factor	≥0.95 [RA2A...]/ ≥0.50 [RA2A...M]	≥0.95	≥0.5	≥0.5
Operating temperature	-20°C to +70°C	-20°C to +70°C	-40°C to +80°C	-40°C to +80°C
Terminals	FASTONS 6.35 mm	FASTONS 6.35 mm / 4 way plug	M4 screw / Control pins	M4 screw / Plug terminal
Approvals/Marks	CE - UR - CSA - EAC	CE - cURus - EAC	CE - UR - CSA - VDE - EAC	CE - UR - CSA - VDE - EAC
References				
	25 / 40 AAC per pole	25 / 40 AAC per pole	50 / 75 AAC per pole	50 / 75 AAC per pole
230 Vrms	25 AAC: RA2A23D25	25 AAC: RA2A23D25C	50 AAC: RKD2A23D50C	50 AAC: RKD2A23D50P
	RA2A23D25M	40 AAC: RA2A23D40C	50 AAC: RKD2A23D51C	50 AAC: RKD2A23D51P
	40 AAC: RA2A23D40		75 AAC: RKD2A23D75C	75 AAC: RKD2A23D75P
480 Vrms	RA2A23D40M			
	25 AAC: RA2A48D25			
	RA2A48D25M			
600 Vrms	40 AAC: RA2A48D40			
	RA2A48D40M			
	25 AAC: RA2A60D25	25 AAC: RA2A60D25C	50 AAC: RKX2Y60D50C	50 AAC: RKX2Y60D50P
	RA2A60D25M	40 AAC: RA2A60D40C	50 AAC: RKX2A60D51C	50 AAC: RKX2A60D51P
	40 AAC: RA2A60D40	75 AAC: RKX2Y60D75C	75 AAC: RKX2Y60D75P	
	RA2A60D40M			

X = must be replaced with 'D' for dual control, blank for common control
Y = must be replaced with 'A' for zero cross switching, 'B' for instant on switching

Solid state contactors, 1-phase

Slimline, DIN-rail mounting - AC output

Types	RGC..15KKE 20 AAC	RGC..25KKE RGC..32KKE 25/30 AAC	RGC..32KGE 37 AAC	RGC..30KKE 30 AAC
Single-phase, semiconductor contactors with integrated heatsink, LED indication and IP20 protection, AC operating frequency 45-65 Hz, rated isolation voltage ≥ 4000 Vrms, 100 kArms short circuit current rating, motor ratings according to UL508, integrated varistor on output.				
Dimensions HxWxD (mm)	110 x 17.8 x 103.5	110 x 17.8 x 103.5	110 x 17.8 x 103.5	110 x 22.5 x 141
Features	17.8 mm wide solid state contactor, DC or AC control voltage, screw terminals for power and control, E-type layout	17.8 mm wide solid state contactor, DC or AC control voltage, screw terminals for power and control, E-type layout	17.8 mm wide solid state contactor, DC control voltage, box clamps for power terminals and screw terminals for control, E-type layout	22.5 mm wide solid state contactor, DC or AC control voltage, screw terminals for power and control, E-type layout

Input specifications

Control input range	3-32 VDC [RG.23D.] 4-32 VDC [RG.60D.] 20-275 VAC, 24-190 VDC [RG..A.]	3-32 VDC [RG.23D.] 4-32 VDC [RG.60D.] 20-275 VAC, 24-190 VDC [RG..A.]	4-32 VDC	3-32 VDC [RG.23D.] 4-32 VDC [RG.60D.] 20-275 VAC, 24-190 VDC [RG..A.]
Max. input current	11 mA DC [RG..D.] 30 mA AC [RG..A.]	11 mA DC [RG..D.] 30 mA AC [RG..A.]	11 mA DC	11 mA DC [RG..D.] 30 mA AC [RG..A.]

Output specifications

Rated operational current AC 51 @ $T_a=40^\circ\text{C}$	20 AAC	25 AAC [RGC..25.] 30 AAC [RGC..32.]	37 AAC	30 AAC
AC 53a @ $T_a=40^\circ\text{C}$	5 AAC	5 AAC	5 AAC	8 AAC
Min. operational current	150 mA	250 mA [RGC..25.] 500 mA [RGC..32.]	500 mA	250 mA
Non rep. surge current (t=10 ms)	325 Ap	600 Ap [RGC..25.] 1900 Ap [RGC..32.]	1150 Ap	600 Ap
Off-state leakage current	3 mA AC	3 mA AC	3 mA AC	3 mA AC
I^2t for fusing (t=10 ms)	525 A ² s	1800 A ² s [RGC..25.] 18000 A ² s [RGC..32.]	18000 A ² s	1800 A ² s
Critical dV/dt (@ T_j init=40°C)	1000 V/ μ s	1000 V/ μ s	1000 V/ μ s	1000 V/ μ s

General specifications

Operational voltage range	24-240 VAC +10% [RG.23..] 42-600 VAC +10% [RG.60..]	24-240 VAC +10% [RG.23..] 42-600 VAC +10% [RG.60..]	42-600 VAC +10%	24-240 VAC +10% [RG.23..] 42-600 VAC +10% [RG.60..]
Blocking voltage	800 Vp [RGC.23.] 1200 Vp [RGC.60.]	800 Vp [RGC.23.] 1200 Vp [RGC.60.]	1200 Vp	800 Vp [RGC.23.] 1200 Vp [RGC.60.]
Power factor	≥ 0.5 at rated voltage	≥ 0.5 at rated voltage	≥ 0.5 at rated voltage	≥ 0.5 at rated voltage
Operating temperature	-40°C to +80°C	-40°C to +80°C	-40°C to +80°C	-40°C to +80°C
Approvals/Marks	CE - cULus - VDE - EAC - GL	CE - cULus - VDE* - EAC - GL*	CE - cULus - EAC	CE - cULus - VDE - EAC - GL

References

DC control voltage				
230 VAC, 800 Vp	20 AAC: RGC1A23D15KKE	25 AAC: RGC1A23D25KKE		30 AAC: RGC1A23D30KKE
600 VAC, 1200 Vp	20 AAC: RGC1A60D15KKE	25 AAC: RGC1A60D25KKE		30 AAC: RGC1A60D30KKE
600 VAC, 1200 Vp, 18000 A ² s		30 AAC: RGC1A60D32KKE	37 AAC: RGC1A60D32KGE	
AC/DC control voltage				
230 VAC, 800 Vp	20 AAC: RGC1A23A15KKE	25 AAC: RGC1A23A25KKE		30 AAC: RGC1A23A30KKE
600 VAC, 1200 Vp	20 AAC: RGC1A60A15KKE	25 AAC: RGC1A60A25KKE		30 AAC: RGC1A60A30KKE





Instant On (Random) Switching available on request (RGC1B60D...)

* not applicable to RGC..32

CARLO GAVAZZI Automation Components. Specifications are subject to change without notice. Illustrations are for example only.

Solid state contactors, 1-phase

Slimline, DIN-rail mounting - AC output

Types	RGC..15MKE 20 AAC	RGC..25MKE RGC..32MKE 25/30 AAC	RGC..32MGE 37 AAC	RGC..30MKE 30 AAC
Single-phase, semiconductor contactors with integrated heatsink, LED indication and IP20 protection, AC operating frequency 45-65 Hz, rated isolation voltage ≥ 4000 Vrms, 100 kArms short circuit current rating, motor ratings according to UL508, integrated varistor on output.				
Dimensions HxWxD (mm)	110 x 17.8 x 114.5	110 x 17.8 x 114.5	110 x 17.8 x 114.5	110 x 22.5 x 152
Features	17.8 mm wide solid state contactor, DC or AC control voltage range, screw terminals with captivated clamp for power terminals and spring plug for control, E-type layout	17.8 mm wide solid state contactor, DC or AC control voltage range, screw terminals with captivated clamp for power terminals and spring plug for control, E-type layout	17.8 mm wide solid state contactor, DC control voltage range, box clamps for power terminals and spring plug for control, E-type layout	22.5 mm wide solid state contactor, DC or AC control voltage range, screw terminals with captivated clamp for power terminals and spring plug for control, E-type layout

Input specifications

Control input range	3-32 VDC [RG.23D.] / 4-32 VDC [RG.60D.] 20-275 VAC, 24-190 VDC [RG..A.]	3-32 VDC [RG.23D.] / 4-32 VDC [RG.60D.] 20-275 VAC, 24-190 VDC [RG..A.]	4-32 VDC	3-32 VDC [RG.23D.] / 4-32 VDC [RG.60D.] 20-275 VAC, 24-190 VDC [RG..A.]
Max. input current	11 mADC [RG..D.] 30 mAAC [RG..A.]	11 mADC [RG..D.] 30 mAAC [RG..A.]	11 mADC	11 mADC [RG..D.] 30 mAAC [RG..A.]

Output specifications

Rated operational current				
AC 51 @ Ta=40°C	20 AAC	25 AAC [RGC..25.] 30 AAC [RGC..32.]	37 AAC	30 AAC
AC 53a @ Ta=40°C	5 AAC	5 AAC	5 AAC	8 AAC
Min. operational current	150 mA	250 mA [RGC..25.] 500 mA [RGC..32.]	500 mA	250 mA
Non rep. surge current (t=10 ms)	325 Ap	600 Ap [RGC..25.] 1900 Ap [RGC..32.]	1900 Ap	600 Ap
Off-state leakage current	3 mAAC	3 mAAC	3 mAAC	3 mAAC
I ² t for fusing (t=10 ms)	525 A ² s	1800 A ² s [RGC..25.] 18000 A ² s [RGC..32.]	18000 A ² s	1800 A ² s
Critical dV/dt (@ Tj init=40°C)	1000 V/μs	1000 V/μs	1000 V/μs	1000 V/μs

General specifications

Operational voltage range	24-240 VAC +10% [RG.23..] 42-600 VAC +10% [RG.60..]	24-240 VAC +10% [RG.23..] 42-600 VAC +10% [RG.60..]	42-600 VAC +10%	24-240 VAC +10% [RG.23..] 42-600 VAC +10% [RG.60..]
Blocking voltage	800 Vp [RGC.23.] 1200 Vp [RGC.60.]	800 Vp [RGC.23.] 1200 Vp [RGC.60.]	1200 Vp	800 Vp [RGC.23.] 1200 Vp [RGC.60.]
Power factor	≥ 0.5 at rated voltage	≥ 0.5 at rated voltage	≥ 0.5 at rated voltage	≥ 0.5 at rated voltage
Operating temperature	-40°C to +80°C	-40°C to +80°C	-40°C to +80°C	-40°C to +80°C
Approvals/Marks	CE - cULus - VDE - EAC - GL	CE - cULus - VDE* - EAC - GL*	CE - cULus - EAC	CE - cULus - VDE - EAC - GL



References

DC control voltage				
230 VAC, 800 Vp	20 AAC: RGC1A23D15MKE	25 AAC: RGC1A23D25MKE		30 AAC: RGC1A23D30MKE
600 VAC, 1200 Vp	20 AAC: RGC1A60D15MKE	25 AAC: RGC1A60D25MKE		30 AAC: RGC1A60D30MKE
600 VAC, 1200 Vp, 18000 A ² s		30 AAC: RGC1A60D32MKE	37 AAC: RGC1A60D32MGE	
AC/DC control voltage				
230 VAC, 800 Vp	20 AAC: RGC1A23A15MKE	25 AAC: RGC1A23A25MKE		30 AAC: RGC1A23A30MKE
600 VAC, 1200 Vp	20 AAC: RGC1A60A15MKE	25 AAC: RGC1A60A25MKE		30 AAC: RGC1A60A30MKE

Instant On (Random) Switching available on request (RGC1B60D...)
* not applicable to RGC..32

Solid state contactors, 1-phase

Slimline, DIN-rail mounting - AC output





Types	RGC..15KGU 20 AAC	RGC..25KGU 25 AAC	RGC..30KGU 30 AAC
Single-phase, semiconductor contactors with integrated heatsink, LED indication and IP20 protection, AC operating frequency 45-65 Hz, rated isolation voltage ≥ 4000 Vrms, 100 kArms short circuit current rating, motor ratings according to UL508.			
Dimensions HxWxD (mm)	110 x 17.8 x 103.5	110 x 17.8 x 103.5	110 x 22.5 x 141
Features	17.8 mm wide solid state contactor, integrated varistor for overvoltage protection, DC or AC control voltage range, screw terminals with captivated clamp for connection of control terminals and box clamps for power terminals, U-type layout	17.8 mm wide solid state contactor, integrated varistor for overvoltage protection, DC or AC control voltage range, screw terminals with captivated clamp for connection of control terminals and box clamps for power terminals, U-type layout	22.5 mm wide solid state contactor, integrated varistor for overvoltage protection, DC or AC control voltage range, screw terminals with captivated clamp for connection of control terminals and box clamps for power terminals, U-type layout
Input specifications			
Control input range	3-32 VDC [RG.23D.] 4-32 VDC [RG.60D.] 20-275 VAC, 24-190 VDC [RG..A.]	3-32 VDC [RG.23D.] 4-32 VDC [RG.60D.] 20-275 VAC, 24-190 VDC [RG..A.]	3-32 VDC [RG.23D.] 4-32 VDC [RG.60D.] 20-275 VAC, 24-190 VDC [RG..A.]
Max. input current	11 mADC [RG..D.] 30 mAAC [RG..A.]	11 mADC [RG..D.] 30 mAAC [RG..A.]	11 mADC [RG..D.] 30 mAAC [RG..A.]
Output specifications			
Rated operational current			
AC 51 @ $T_a=40^\circ\text{C}$	20 AAC	25 AAC	30 AAC
AC 53a @ $T_a=40^\circ\text{C}$	5 AAC	5 AAC	8 AAC
Min. operational current	150 mA	250 mA	250 mA
Non rep. surge current (t=10 ms)	325 AP	600 AP	600 AP
Off-state leakage current	3 mAAC	3 mAAC	3 mAAC
I^2t for fusing (t=10 ms)	525 A ² s	1800 A ² s	1800 A ² s
Critical dV/dt (@ T_j init=40°C)	1000 V/ μ s	1000 V/ μ s	1000 V/ μ s
General specifications			
Operational voltage range	24-240 VAC +10% [RG.23..] 42-600 VAC +10% [RG.60..]	24-240 VAC +10% [RG.23..] 42-600 VAC +10% [RG.60..]	24-240 VAC +10% [RG.23..] 42-600 VAC +10% [RG.60..]
Blocking voltage	800 V _P [RGC.23.] 1200 V _P [RGC.60.]	800 V _P [RGC.23.] 1200 V _P [RGC.60.]	800 V _P [RGC.23.] 1200 V _P [RGC.60.]
Power factor	≥ 0.5 at rated voltage	≥ 0.5 at rated voltage	≥ 0.5 at rated voltage
Operating temperature	-40°C to +80°C	-40°C to +80°C	-40°C to +80°C
Approvals/Marks	CE - cULus - VDE - EAC - GL	CE - cULus - VDE - EAC - GL	CE - cULus - VDE - EAC - GL
References			
DC control voltage			
230 VAC, 800 V _P	20 AAC: RGC1A23D15KGU	25 AAC: RGC1A23D25KGU	30 AAC: RGC1A23D30KGU
600 VAC, 1200 V _P	20 AAC: RGC1A60D15KGU	25 AAC: RGC1A60D25KGU	30 AAC: RGC1A60D30KGU
AC/DC control voltage			
230 VAC, 800 V _P	20 AAC: RGC1A23A15KGU	25 AAC: RGC1A23A25KGU	30 AAC: RGC1A23A30KGU
600 VAC, 1200 V _P	20 AAC: RGC1A60A15KGU	25 AAC: RGC1A60A20KGU	30 AAC: RGC1A60A30KGU

Instant On (Random) Switching available on request (RGC1B60D...)

CARLO GAVAZZI Automation Components. Specifications are subject to change without notice. Illustrations are for example only.

Solid state contactors, 1-phase

Slimline, DIN-rail mounting - AC output

Types	RGC..40/42KGE 40/43 AAC	RGC..40/42MGE 40/43 AAC	RGC..60/62KGE 60/65 AAC	RGC..62MGE 65 AAC
Single-phase, semiconductor contactors with integrated heatsink, LED indication and IP20 protection, AC operating frequency 45-65 Hz, rated isolation voltage ≥ 4000 Vrms, 100 kArms short circuit current rating, motor ratings according to UL508.				
Dimensions HxWxD (mm)	110 x 35.6 x 141	110 x 35.6 x 152	110 x 69.1 x 141	110 x 69.1 x 152
Features	35 mm wide solid state contactor, integrated varistor, DC or AC control voltage, screw terminals for control, box clamp for power terminals, E-type layout	35 mm wide solid state contactor, integrated varistor, DC or AC control voltage, spring plug for control, box clamp for power terminals, E-type layout	70 mm wide solid state contactor, integrated varistor, DC or AC control voltage, screw terminals for control, box clamp for power terminals, E-type layout	70 mm wide solid state contactor, integrated varistor, DC or AC control voltage, spring plug for control, box clamp for power terminals, E-type layout

Input specifications

Control input range	3-32 VDC [RG..23D..] 4-32 VDC [RG..60D..] 20-275 VAC, 24-190 VDC [RG..A..]	4-32 VDC [RG..D..] 20-275 VAC, 24-190 VDC [RG..A..]	3-32 VDC [RG..23D..] 4-32 VDC [RG..60D..] 20-275 VAC, 24-190 VDC [RG..A..]	4-32 VDC [RG..D..] 20-275 VAC, 24-190 VDC [RG..A..]
Max. input current	11 mA DC [RG..D..] 30 mA AC [RG..A..]	11 mA DC [RG..D..] 30 mA AC [RG..A..]	11 mA DC [RG..D..] 30 mA AC [RG..A..]	11 mA DC [RG..D..] 30 mA AC [RG..A..]

Output specifications

Rated operational current AC 51 @ $T_a=40^\circ\text{C}$	40 AAC [RGC..40] 43 AAC [RGC..42]	40 AAC [RGC..40] 43 AAC [RGC..42]	60 AAC [RGC..60] 65 AAC [RGC..62]	65 AAC
AC 53a @ $T_a=40^\circ\text{C}$	13 AAC [RGC..40] 16 AAC [RGC..42]	13 AAC [RGC..40] 16 AAC [RGC..42]	14.8 AAC [RGC..60] 20 AAC [RGC..62]	20 AAC
Min. operational current	400 mA AC [RGC..40] 500 mA AC [RGC..42]	400 mA AC [RGC..40] 500 mA AC [RGC..42]	400 mA AC [RGC..60] 500 mA AC [RGC..62]	500 mA AC
Non rep. surge current (t=10 ms)	800 Ap [RGC..40] 1900 Ap [RGC..42]	800 Ap [RGC..40] 1900 Ap [RGC..42]	800 Ap [RGC..60] 1900 Ap [RGC..62]	1900 Ap
Off-state leakage current	3 mA AC	3 mA AC	3 mA AC	3 mA AC
I ² t for fusing (t=10 ms)	3200 A ² s [RGC..40] 18000 A ² s [RGC..42]	3200 A ² s [RGC..40] 18000 A ² s [RGC..42]	3200 A ² s [RGC..60] 18000 A ² s [RGC..62]	18000 A ² s
Critical dV/dt (@ T_j init=40°C)	1000 V/ μs	1000 V/ μs	1000 V/ μs	1000 V/ μs

General specifications

Operational voltage range	24-240 VAC +10% [RG..23..] 42-600 VAC +10% [RG..60..]	42-600 VAC +10%	24-240 VAC +10% [RG..23..] 42-600 VAC +10% [RG..60..]	42-600 VAC +10%
Blocking voltage	800 V _P [RGC..23..] 1200 V _P [RGC..60..]	1200 V _P	800 V _P [RGC..23..] 1200 V _P [RGC..60..]	1200 V _P
Power factor	≥ 0.5 at rated voltage	≥ 0.5 at rated voltage	≥ 0.5 at rated voltage	≥ 0.5 at rated voltage
Operating temperature	-40°C to +80°C	-40°C to +80°C	-40°C to +80°C	-40°C to +80°C
Approvals/Marks	CE - cULus - VDE - EAC	CE - cULus - VDE - EAC	CE - cULus - VDE - EAC	CE - cULus - VDE - EAC



References

230 VAC, 800 V _P , 3200 A ² s	40 AAC: RGC1A23X40KGE		60 AAC: RGC1A23X60KGE	
230 VAC, 800 V _P , 18000 A ² s	43 AAC: RGC1A23X42KGE		65 AAC: RGC1A23X62KGE	
600 VAC, 1200 V _P , 3200 A ² s	40 AAC: RGC1A60X40KGE	40 AAC: RGC1A60X40MGE	60 AAC: RGC1A60X60KGE	
600 VAC, 1200 V _P , 18000 A ² s	43 AAC: RGC1A60X42KGE	43 AAC: RGC1A60X42MGE	65 AAC: RGC1A60X62KGE	65 AAC: RGC1A60X62MGE

X must be replaced with D for DC control 3-32 VDC, 4-32 VDC (for 600 VAC versions)
 X must be replaced with A for AC control 20-275 VAC, 24-190 VDC
 RGC1B.. models for Instant On (Random) switching are available on request
 *690 VAC variants are CE marked only and do not include a varistor across the output

Solid state contactors, 1-phase

Slimline, DIN-rail mounting - AC output





Types	RGC..40/42KGU 40/43 AAC	RGC..60/62KGU 60/65 AAC
Single-phase, semiconductor contactors with integrated heatsink, LED indication and IP20 protection, rated isolation voltage ≥ 4000 Vrms, 100 kArms short circuit current rating and motor ratings according to UL508 for AC output switching.		
Dimensions HxWxD (mm)	110 x 35.6 x 141	110 x 69.1 x 141
Features	35 mm wide solid state contactor, integrated varistor, DC or AC control voltage, screw terminals for control, box clamp for power terminals, U-type layout	70 mm wide solid state contactor, integrated varistor, DC or AC control voltage, screw terminals for control, box clamp for power terminals, U-type layout
Input specifications		
Control input range	4-32 VDC [RG..D..] 20-275 VAC, 24-190 VDC [RG..A..]	4-32 VDC [RG..D..] 20-275 VAC, 24-190 VDC [RG..A..]
Max. input current	11 mA DC [RG..D..] 30 mA AC [RG..A..]	11 mA DC [RG..D..] 30 mA AC [RG..A..]
Output specifications		
Rated operational current		
AC-51 @ Ta=40°C	40 AAC [RGC..40] 43 AAC [RGC..42]	60 AAC [RGC..60] 65 AAC [RGC..62]
AC-53a @ Ta=40°C	13 AAC [RGC..40] 16 AAC [RGC..42]	14.8 AAC [RGC..60] 20 AAC [RGC..62]
Min. operational current	400 mA AC [RGC..40] 500 mA AC [RGC..42]	400 mA AC [RGC..60] 500 mA AC [RGC..62]
Non rep. surge current (t=10 ms)	800 Ap [RGC..40] 1900 Ap [RGC..42]	800 Ap [RGC..60] 1900 Ap [RGC..62]
Off-state leakage current	3 mA AC	3 mA AC
I ² t for fusing (t=10 ms)	3200 A ² s [RGC..40] 18000 A ² s [RGC..42]	3200 A ² s [RGC..60] 18000 A ² s [RGC..62]
Critical dV/dt (@ Tj init= 40°C)	1000 V/μs	1000 V/μs
General specifications		
Operational voltage range	42-600 VAC +10%	42-600 VAC +10%
Blocking voltage	1200 Vp	1200 Vp
Power factor	≥ 0.5 at rated voltage	≥ 0.5 at rated voltage
Operating temperature	-40°C to +80°C	-40°C to +80°C
Approvals/Marks	CE - cULus - VDE - EAC	CE - cULus - VDE - EAC
References		
600 VAC, 1200 Vp, 3200 A ² s	40 AAC: RGC1A60X40KGU	60 AAC: RGC1A60X60KGU
600 VAC, 1200 Vp, 18000 A ² s	43 AAC: RGC1A60X42KGU	65 AAC: RGC1A60X62KGU

X must be replaced with D for DC control 4-32 VDC. X must be replaced with A for AC control 20-275 VAC, 24-190 VDC
 RGC1B.. models for Instant On (Random) switching are available on request

CARLO GAVAZZI Automation Components. Specifications are subject to change without notice. Illustrations are for example only.

Solid state contactors, 1-phase

Slimline, DIN-rail mounting - AC output, high blocking voltage

Types	RGH..15KKE 23 AAC	RGH..31KKE 30 AAC	RGH..41KGE RGH..41KGU 40 AAC	RGH..60KGE RGH..60KGU 60 AAC
Single-phase, semiconductor contactors with integrated heatsink, LED indication and IP20 protection, AC operating frequency 45-65 Hz, rated isolation voltage ≥ 4000 Vrms, 100 kArms short circuit current rating, motor ratings according to UL508.				
Dimensions HxWxD (mm)	110 x 17.8 x 103.5	110 x 22.5 x 141	110 x 35.6 x 141	110 x 69.1 x 141
Features	17.8 mm wide solid state contactor, integrated varistor, DC or AC control voltage, screw terminals for control and power terminals, E-type layout	22.5 mm wide solid state contactor, integrated varistor, DC or AC control voltage, screw terminals for control and power terminals, E-type layout	35 mm wide solid state contactor, integrated varistor, DC or AC control voltage, screw terminals for control and box clamps for power terminals, E-type or U-type layout	70 mm wide solid state contactor, integrated varistor, DC or AC control voltage, screw terminals for control and box clamps for power terminals, E-type or U-type layout

Input specifications

Control input range	4-32 VDC [RG..D..] 20-275 VAC, 24-190 VDC [RG..A..]	4-32 VDC [RG..D..] 20-275 VAC, 24-190 VDC [RG..A..]	4-32 VDC [RG..D..] 20-275 VAC, 24-190 VDC [RG..A..]	4-32 VDC [RG..D..] 20-275 VAC, 24-190 VDC [RG..A..]
Max. input current	11 mA DC [RG..D..] 30 mA AC [RG..A..]	11 mA DC [RG..D..] 30 mA AC [RG..A..]	11 mA DC [RG..D..] 30 mA AC [RG..A..]	11 mA DC [RG..D..] 30 mA AC [RG..A..]

Output specifications

Rated operational current AC 51 @ $T_a=40^\circ\text{C}$	23 AAC	30 AAC	40 AAC	60 AAC
AC 53a @ $T_a=40^\circ\text{C}$	5 AAC	10 AAC	13 AAC	18 AAC
Min. operational current	400 mA AC	400 mA AC	400 mA AC	400 mA AC
Non rep. surge current (t=10 ms)	1150 Ap	1150 Ap	1150 Ap	1150 Ap
Off-state leakage current	3 mA AC	3 mA AC	3 mA AC	3 mA AC
I ² t for fusing (t=10 ms)	6600 A ² s	6600 A ² s	6600 A ² s	6600 A ² s
Critical dV/dt (@ T_j init=40°C)	1000 V/ μ s	1000 V/ μ s	1000 V/ μ s	1000 V/ μ s

General specifications

Operational voltage range	42-600 VAC +10%	42-600 VAC +10%	42-600 VAC +10% [RG..60..] 42-690 VAC +10% [RG..69..]*	42-600 VAC +10% [RG..60..] 42-690 VAC +10% [RG..69..]*
Blocking voltage	1600 Vp	1600 Vp	1600 Vp	1600 Vp
Power factor	≥ 0.5 at rated voltage	≥ 0.5 at rated voltage	≥ 0.5 at rated voltage	≥ 0.5 at rated voltage
Operating temperature	-40°C to +80°C	-40°C to +80°C	-40°C to +80°C	-40°C to +80°C
Approvals/Marks	CE - cULus - VDE - EAC	CE - cULus - VDE - EAC	CE - cULus - VDE - EAC	CE - cULus - VDE - EAC



References

E-type				
600 VAC, 1600 Vp, DC control	23 AAC: RGH1A60D15KKE	30 AAC: RGH1A60D31KKE	40 AAC: RGH1A60D41KGE	60 AAC: RGH1A60D60KGE
600 VAC, 1600 Vp, AC control	23 AAC: RGH1A60A15KKE	30 AAC: RGH1A60A31KKE	40 AAC: RGH1A60A41KGE	60 AAC: RGH1A60A60KGE
690 VAC, 1600 Vp, DC control			40 AAC: RGH1A69D41KGE*	60 AAC: RGH1A69D60KGE*
690 VAC, 1600 Vp, AC control			40 AAC: RGH1A69A41KGE*	60 AAC: RGH1A69A60KGE*
U-type				
600 VAC, 1600 Vp, DC control			40 AAC: RGH1A60D41KGU	60 AAC: RGH1A60D60KGU
600 VAC, 1600 Vp, AC control			40 AAC: RGH1A60A41KGU	60 AAC: RGH1A60A60KGU

*690 VAC variants are CE marked only and do not include a varistor across the output

Solid state contactors, 1-phase

Slimline, DIN-rail mounting - AC output, high blocking voltage

Types	RGH..15MKE 23 AAC	RGH..31MKE 30 AAC	RGH..41MGE 40 AAC
Single-phase, semiconductor contactors with integrated heatsink, LED indication and IP20 protection, AC operating frequency 45-65 Hz, rated isolation voltage ≥ 4000 Vrms, 100 kArms short circuit current rating, motor ratings according to UL508.			
Dimensions HxWxD (mm)	110 x 17.8 x 114.5	110 x 22.5 x 152	110 x 35.6 x 152
Features	17.8 mm wide solid state contactor, integrated varistor, DC or AC control voltage, spring plug for control and screw terminals for power, E-type layout	22.5 mm wide solid state contactor, integrated varistor, DC or AC control voltage, spring plug for control and screw terminals for power, E-type layout	35 mm wide solid state contactor, integrated varistor, DC or AC control voltage, spring plug for control and box clamps for power terminals, E-type layout

Input specifications

Control input range	4-32 VDC [RG..D..] 20-275 VAC, 24-190 VDC [RG..A..]	4-32 VDC [RG..D..] 20-275 VAC, 24-190 VDC [RG..A..]	4-32 VDC [RG..D..] 20-275 VAC, 24-190 VDC [RG..A..]
Max. input current	11 mA DC [RG..D..] 30 mA AC [RG..A..]	11 mA DC [RG..D..] 30 mA AC [RG..A..]	11 mA DC [RG..D..] 30 mA AC [RG..A..]

Output specifications

Rated operational current AC 51 @ $T_a=40^\circ\text{C}$	23 AAC	30 AAC	40 AAC
AC 53a @ $T_a=40^\circ\text{C}$	5 AAC	10 AAC	13 AAC
Min. operational current	400 mA AC	400 mA AC	400 mA AC
Non rep. surge current (t=10 ms)	1150 A _p	1150 A _p	1150 A _p
Off-state leakage current	3 mA AC	3 mA AC	3 mA AC
I ² t for fusing (t=10 ms)	6600 A ² s	6600 A ² s	6600 A ² s
Critical dV/dt (@ T _j init=40°C)	1000 V/ μs	1000 V/ μs	1000 V/ μs

General specifications





Operational voltage range	42-600 VAC +10%	42-600 VAC +10%	42-600 VAC +10%
Blocking voltage	1600 V _p	1600 V _p	1600 V _p
Power factor	≥ 0.5 at rated voltage	≥ 0.5 at rated voltage	≥ 0.5 at rated voltage
Operating temperature	-40°C to +80°C	-40°C to +80°C	-40°C to +80°C
Approvals/Marks	CE - cULus - VDE - EAC	CE - cULus - VDE - EAC	CE - cULus - VDE - EAC

References

600 VAC, 1600 V _p , DC control	23 AAC: RGH1A60D15MKE	30 AAC: RGH1A60D31MKE	40 AAC: RGH1A60D41MGE
600 VAC, 1600 V _p , AC control		30 AAC: RGH1A60A31MKE	40 AAC: RGH1A60A41MGE

Solid state contactors, 1-phase

DIN-rail mounting - AC output with over temperature protection

Types	RG..30..P 30 AAC	RG..40/42..P 40/43 AAC	RG..60/62..P 60/65 AAC	RG..90/92..P 85 AAC
Single-phase, semiconductor contactors with integrated heatsink, LED indication and IP20 protection, AC operating frequency 45-65 Hz, rated isolation voltage ≥ 4000 Vrms, 100 kArms short circuit current rating, motor ratings according to UL508.				
Dimensions HxWxD (mm)	110 x 22.5 x 168	110x 35.6 x 168	110 x 69.1 x 168	126 x 69.1 x 168 (with fan)
Features	Integrated over temperature protection against over heating, screw terminals with captivated clamp for connection of power terminals and box clamps for control terminals	Integrated over temperature protection against over heating, box clamps for connection of power and control terminals	Integrated over temperature protection against over heating, box clamps for connection of power and control terminals	Integrated over temperature protection against over heating, box clamps for connection of power and control terminals

Input specifications

Control input range	5-32 VDC [RG.D.] 20-275 VAC, 24-190 VDC [RG.A.]	5-32 VDC [RG.D.] 20-275 VAC, 24-190 VDC [RG.A.]	5-32 VDC [RG.D.] 20-275 VAC, 24-190 VDC [RG.A.]	5-32 VDC [RG.D.] 20-275 VAC, 24-190 VDC [RG.A.]
Max. input current	24 mADC [RG..D.] 35 mAAC [RG..A.]	24 mADC [RG..D.] 35 mAAC [RG..A.]	23 mADC [RG..D.] 35 mAAC [RG..A.]	23 mADC [RG..D.] 35 mAAC [RG..A.]

Supply voltage

Rated supply voltage	24 VDC -15%, +20%	24 VDC -15%, +20%	24 VDC -15%, +20%	24 VDC -15%, +20%
Max. current rating	50 mADC	50 mADC	50 mADC	50 mADC (fan rating 24VDC/50 mA)

Over temperature alarm

Alarm output	PNP open collector normally closed, max. 24 VDC / 50 mA [RGC.D.P] Potential free normally closed, max. 24 VDC / 50 mA [RGC.A.P]	PNP open collector normally closed, max. 24 VDC / 50 mA [RGC.D.P] Potential free normally closed, max. 24 VDC / 50 mA [RGC.A.P]	PNP open collector normally closed, max. 24 VDC / 50 mA [RGC.D.P] Potential free normally closed, max. 24 VDC / 50 mA [RGC.A.P]	PNP open collector normally closed, max. 24 VDC / 50 mA [RGC.D.P] Potential free normally closed, max. 24 VDC / 50 mA [RGC.A.P]
--------------	--	--	--	--

Output specifications

Rated operational current				
AC 51 @ Ta=40°C	30 AAC	40 AAC [RGC..40], 43 AAC [RGC..42]	60 AAC [RGC..60] 65 AAC [RGC..62]	85 AAC
AC 53a @ Ta=40°C	8 AAC	13 AAC [RGC..40], 16 AAC [RGC..42]	14.8 AAC [RGC..60] 20 AAC [RGC..62]	18 AAC [RGC..90] 20 AAC [RGC..92]
Min. operational current	250 mA	400 mAAC [RGC..40], 500 mAAC [RGC..42]	400 mA [RGC..60] 500 mA [RGC..62]	400 mA [RGC..90] 500 mA [RGC..92]
Non rep. surge current (t=10 ms)	600 Ap	800 Ap [RGC..40] 1900 Ap [RGC..42]	800 Ap [RGC..60] 1900 Ap [RGC..62]	1150 Ap [RGC..90] 1900 Ap [RGC..92]
Off-state leakage current	3 mAAC	3 mAAC	3 mAAC	3 mAAC
I ² t for fusing (t=10 ms)	1800 A ² s	3200 A ² s [RGC..40], 18000 A ² s [RGC..42]	3200 A ² s [RGC..60] 18000 A ² s [RGC..62]	6600 A ² s [RGC..90] 18000 A ² s [RGC..92]
Critical dV/dt off-state (@ Tj init=40°C)	1000 V/μs	1000 V/μs	1000 V/μs	1000 V/μs

General specifications

Operational voltage range	42-600 VAC +10%	42-600 VAC +10%	42-600 VAC +10%	42-600 VAC +10%
Blocking voltage	1200 Vp	1200 Vp	1200 Vp	1200 Vp
Power factor	≥ 0.5 at rated voltage	≥ 0.5 at rated voltage	≥ 0.5 at rated voltage	≥ 0.5 at rated voltage
Operating temperature	-40°C to +70°C	-40°C to +70°C	-40°C to +70°C	-40°C to +70°C
Approvals/Marks	CE - cULus - VDE - EAC	CE - cULus - VDE - EAC	CE - cULus - VDE - EAC	CE - cULus - VDE - EAC

References

DC control voltage				
600 VAC, 1200 Vp, U-type		40 AAC: RGC1A60D40GGUP	60 AAC: RGC1A60D60GGUP	85 AAC: RGC1A60D90GGUP
600 VAC, 1200 Vp, E-type	30 AAC: RGC1A60D30GKEP	43 AAC: RGC1A60D42GGEP	65 AAC: RGC1A60D62GGEP	85 AAC: RGC1A60D90GGEP
600 VAC, 1200 Vp, E-type, high I ² t				85 AAC: RGC1A60D92GGEP
AC/DC control voltage				
600 VAC, 1200 Vp, U-type		40 AAC: RGC1A60A40GGUP	60 AAC: RGC1A60A60GGUP	85 AAC: RGC1A60A90GGUP
600 VAC, 1200 Vp, E-type	30 AAC: RGC1A60A30GKEP	43 AAC: RGC1A60A42GGEP	65 AAC: RGC1A60A62GGEP	85 AAC: RGC1A60A90GGEP
600 VAC, 1200 Vp, E-type, high I ² t				85 AAC: RGC1A60A92GGEP

Solid state contactors, 1-phase

DIN-rail mounting - DC output

Types

RGC1D..15KKE
15 ADC

Single-phase, semiconductor contactors with integrated heatsink, LED indication and IP20 protection, rated isolation voltage ≥ 4000 Vrms, 100 kArms short circuit current rating, motor ratings according to UL508.



Dimensions HxWxD (mm)

110 x 17.8 x 141

Features

17.8 mm wide solid state contactor for DC switching with integrated free wheeling diode, DC control, screw terminals for power and control, E-type layout

Input specifications

Control input range

4.5-32 VDC

Max. input current

13.7 mADC

Output specifications

DC I @ 40°C

15 ADC

Min. operational current

20 mADC

Non rep. surge current
(I_{tsm}) (t=10 ms)

200 ADC (10us)

Off-state leakage current

1.5 mADC

General specifications

Operational voltage range

24-1000 VDC [CE]
24-600 VDC [UL508]

Blocking voltage

1200 V_P

Operating temperature

-40°C to +80°C

Approvals/Marks

CE - EAC - cULus





References

1000 VDC

15 ADC: RGC1D1000D15KKE



Solid state contactors, 1-phase

DIN-rail mounting - AC output, integrated system monitoring

Types	RGCI A..15/25/31KEM 20/25/30 AAC	RGCI A..30KEM 30 AAC	RGCI A..42GEM 43 AAC	RGCI A..62GEM 65 AAC
Single-phase, semiconductor contactors with integrated monitoring, E-type configuration, LED indication and IP20 protection, AC operating frequency 45-65 Hz, rated isolation voltage ≥ 4000 Vrms, 100 kArms short circuit current rating.				
Dimensions HxWxD (mm)	110 x 17.8 x 134	110 x 22.5 x 171.5	110 x 35.6 x 171.5	110 x 70 x 171.5
Features	17.8 mm wide solid state contactor, integrated monitoring for SSR and load malfunction, integrated varistor, DC control and supply, transistor output for remote alarm signalling	22.5 mm wide solid state contactor, integrated monitoring for SSR and load malfunction, integrated varistor, DC control and supply, transistor output for remote alarm signalling	35 mm wide solid state contactor, integrated monitoring for SSR and load malfunction, integrated varistor, DC control and supply, transistor output for remote alarm signalling	70 mm wide solid state contactor, integrated monitoring for SSR and load malfunction, integrated varistor, DC control and supply, transistor output for remote alarm signalling
Input specifications				
Control input range	4-32 VDC	4-32 VDC	4-32 VDC	4-32 VDC
Max. input current	0.5 mA DC at 24 VDC	0.5 mA DC at 24 VDC	0.5 mA DC at 24 VDC	0.5 mA DC at 24 VDC
Supply voltage				
Rated supply voltage	19.2-28.8 VDC	19.2-28.8 VDC	19.2-28.8 VDC	19.2-28.8 VDC
Max. current rating	40 mA	40 mA	40 mA	40 mA
Alarm specifications				
Output type	Transistor, NC, NO max. 35 VDC/100 mA	Transistor, NC, NO max. 35 VDC/100 mA	Transistor, NC, NO max. 35 VDC/100 mA	Transistor, NC, NO max. 35 VDC/100 mA
Alarm Condition	Mains loss, load loss, SSR open and short cct, SSR internal error, supply out of range	Mains loss, load loss, SSR open and short cct, SSR internal error, supply out of range	Mains loss, load loss, SSR open and short cct, SSR internal error, supply out of range	Mains loss, load loss, SSR open and short cct, SSR internal error, supply out of range
Output specifications				
Rated operational current AC 51 @ Ta=40°C	20 AAC [RGC..15] 25 AAC [RGC..25] 30 AAC [RGC..31]	30 AAC	43 AAC	65 AAC
Minimum operational current	150 mA AC [RGC..15] 250 mA AC [RGC..25] 400 mA AC [RGC..31]	250 mA AC	500 mA AC	500 mA AC
Non. rep. surge current I _{tsm} (t=10ms)	325 A _p [RGC..15] 600 A _p [RGC..25] 1150 A _p [RGC..31]	600 A _p	1900 A _p	1900 A _p
Max. off state leakage current	5 mA AC	5 mA AC	5 mA AC	5 mA AC
I ² t for fusing (t=10ms)	525 A ² s [RGC..15] 1800 A ² s [RGC..25] 6600 A ² s [RGC..31]	1800 A ² s	18000 A ² s	18000 A ² s
Critical dV/dt (@ T _j init=40°C)	1000 V/μs	1000 V/μs	1000 V/μs	1000 V/μs
General specifications				
Operational voltage range	42-265 VAC [RGCI A23..] 150-660 VAC [RGCI A60..]	150-660 VAC	150-660 VAC	150-660 VAC
Blocking voltage	800 V _p [RGCI A23..] 1200 V _p [RGCI A60..]	1200 V _p	1200 V _p	1200 V _p
Power factor	≥ 0.9 at rated voltage	≥ 0.9 at rated voltage	≥ 0.9 at rated voltage	≥ 0.9 at rated voltage
Operating temperature	-20°C to +65°C	-20°C to +65°C	-20°C to +65°C	-20°C to +65°C
Approvals/Marks	CE - cULus - EAC	CE - cULus - EAC	CE - cULus - EAC	CE - cULus - EAC
References				
230 VAC, 800 V _p , 525 A ² s	20 AAC: RGCI A23D15KEM			
230 VAC, 800 V _p , 6600 A ² s	30 AAC: RGCI A23D31KEM			
600 VAC, 1200 V _p , 525 A ² s	20 AAC: RGCI A60D15KEM			
600 VAC, 1200 V _p , 1800 A ² s	25 AAC: RGCI A60D25KEM	30 AAC: RGCI A60D30KEM		
600 VAC, 1200 V _p , 6600 A ² s	30 AAC: RGCI A60D31KEM			
600 VAC, 1200 V _p , 18000 A ² s			43 AAC: RGCI A60D42GEM	65 AAC: RGCI A60D62GEM

Solid state contactors, 1-phase

DIN-rail mounting - AC output, integrated current measurement



Types	RGC1S..20/30/31GKEP 23/30 AAC	RGC1S..25GKEP 25 AAC	RGC1S..26GGEP 25 AAC
Single-phase, semiconductor contactors with integrated current measurement, E-type configuration, LED indication and IP20 protection, AC operating frequency 45-65 Hz, rated isolation voltage ≥ 4000 Vrms, 100 kArms short circuit current rating.			
Dimensions HxWxD (mm)	110 x 22.5 x 163	110 x 22.5 x 126	110 x 22.5 x 126
Features	22.5 mm wide solid state contactor, integrated varistor, DC control, local or remote TEACH, detection of partial load failure (1/6), SSR and load malfunction, SSR overheat protection	22.5 mm wide solid state contactor, integrated varistor, DC control, local or remote TEACH, detection of partial load failure (1/6), SSR and load malfunction, SSR overheat protection	22.5 mm wide solid state contactor, integrated varistor, DC control, local or remote TEACH, detection of partial load failure (1/6), SSR and load malfunction, SSR overheat protection
Input specifications			
Control input range	4-32 VDC	4-32 VDC	4-32 VDC
Max. input current	10 mA DC at 24 VDC	10 mA DC at 24 VDC	10 mA DC at 24 VDC
Supply voltage			
Rated supply voltage	24 VDC -15%, +20%	24 VDC -15%, +20%	24 VDC -15%, +20%
Max. current rating	50 mA DC	50 mA DC	50 mA DC
Alarm specifications			
Output type	NC PNP open collector max. 35 VDC/50 mA	NC PNP open collector max. 35 VDC/50 mA	NC PNP open collector max. 35 VDC/50 mA
Alarm Indication	Red LED (flash rate)	Red LED (flash rate)	Red LED (flash rate)
Output specifications			
Rated operational current			
AC 51 @ $T_a=40^\circ\text{C}$	23 AAC [RGC1S..20] 30 AAC [RGC1S..30] 30 AAC [RGC1S..31]	25 AAC	25 AAC
Minimum TEACH / operational current	1.2 AAC	1.2 AAC	1.2 AAC
Minimum partial load current	0.2 AAC	0.2 AAC	0.2 AAC
Detectable partial load failure	$>16.67\%$ from current setpoint	$>16.67\%$ from current setpoint	$>16.67\%$ from current setpoint
Non. rep. surge current I _{sm} (t=10ms)	325 A _p [RGC1S..20] 600 A _p [RGC1S..30] 1150 A _p [RGC1S..31]	600 A _p	1900 A _p
Max. off state leakage current	3 mA AC	3 mA AC	3 mA AC
I ² t for fusing (t=10ms)	525 A ² s [RGC1S..20] 1800 A ² s [RGC1S..30] 6600 A ² s [RGC1S..31]	1800 A ² s	18000 A ² s
Critical dV/dt (@ T _j init=40°C)	1000 V/μs	1000 V/μs	1000 V/μs
General specifications			
Operational voltage range	42-600 VAC +10%	42-600 VAC +10%	42-600 VAC +10%
Blocking voltage	1200 V _p	1200 V _p	1200 V _p
Power factor	≥ 0.9 at rated voltage	≥ 0.9 at rated voltage	≥ 0.9 at rated voltage
Operating temperature	-25°C to +70°C	-25°C to +70°C	-25°C to +70°C
Approvals/Marks	CE - cULus - EAC	CE - cULus - EAC	CE - cULus - EAC
References			
600 VAC, 1200 V _p , 525A ² s	23 AAC: RGC1S60D20GKEP		
600 VAC, 1200 V _p , 1800A ² s	30 AAC: RGC1S60D30GKEP	25 AAC: RGC1S60D25GKEP	
600 VAC, 1200 V _p , 6600A ² s	30 AAC: RGC1S60D31GKEP		
600 VAC, 1200 V _p , 18000A ² s			25 AAC: RGC1S60D26GGEP

GK = screws for control terminals, box clamps for power terminals
GG = box clamps for control terminals, box clamps for power terminals

CARLO GAVAZZI Automation Components. Specifications are subject to change without notice. Illustrations are for example only.

Solid state contactors, 1-phase

DIN-rail mounting - AC output, integrated current measurement



Types	RGC1S..41GG.P 43 AAC	RGC1S..61GG.P 65 AAC	RGC1S..90GGEP 85 AAC
Single-phase, semiconductor contactors with integrated heatsink, LED indication and IP20 protection, AC operating frequency 45-65 Hz, Rated isolation voltage ≥ 4000 Vrms, 100 kArms short circuit current rating, motor ratings according to UL508.			
Dimensions HxWxD (mm)	110 x 35.6 x 163	110 x 69.1 x 163	126 x 69.1 x 163 (with fan)
Features	35 mm wide solid-state contactor, integrated varistor, DC control, local or remote TEACH, detection of partial load failure (1/6), SSR and load malfunction, SSR overheat protection	70 mm wide solid-state contactor, integrated varistor, DC control, local or remote TEACH, detection of partial load failure (1/6), SSR and load malfunction, SSR overheat protection	70 mm wide solid-state contactor with integrated varistor, DC control, local or remote TEACH, detection of partial load failure (1/6), SSR and load malfunction, SSR overheat protection
Input specifications			
Control input range	4-32 VDC	4-32 VDC	4-32 VDC
Max. input current	10 mADC at 24 VDC	10 mADC at 24 VDC	10 mADC at 24 VDC
Supply voltage			
Supply voltage	24 VDC -15%, +20%	24 VDC -15%, +20%	24 VDC -15%, +20%
Max. current rating	50 mADC	50 mADC	50 mADC (fan rating 24 VDC / 50 mA)
Alarm specifications			
Output type	NC PNP open collector max. 35 VDC / 50 mA	NC PNP open collector max. 35 VDC / 50 mA	NC PNP open collector max. 35 VDC / 50 mA
Alarm Indication	Red LED (flash rate)	Red LED (flash rate)	Red LED (flash rate)
Output specifications			
Rated operational current			
AC 51 @ Ta=40°C	43 AAC	65 AAC	85 AAC
Minimum TEACH / operational current	1.2 AAC	5 AAC	5 AAC
Minimum partial load current	0.2 AAC	0.83 AAC	0.83 AAC
Detectable partial load failure	>16.67% from current setpoint	>16.67% from current setpoint	>16.67% from current setpoint
Non. rep. surge current I _{tsm} (t=10 ms)	1900 Ap	1900 Ap	1900 Ap
Max. off state leakage current	3 mAAC	3 mAAC	3 mAAC
I ² t for fusing (t=10 ms)	18000 A ² s	18000 A ² s	18000 A ² s
Critical dV/dt (@ T _j init=40°C)	1000 V/μs	1000 V/μs	1000 V/μs
General specifications			
Operational voltage range	42-600 VAC +10%	42-600 VAC +10%	42-600 VAC +10%
Blocking voltage	1200 V _P	1200 V _P	1200 V _P
Power factor	≥ 0.9 at rated voltage	≥ 0.9 at rated voltage	≥ 0.9 at rated voltage
Operating temperature	-25°C to +70°C	-25°C to +70°C	-25°C to +70°C
Approvals/Marks	CE - cULus - EAC	CE - cULus - EAC	CE - cULus - EAC
References			
600 VAC, 1200 V _P , E-type	43 AAC: RGC1S60D41GGEP	65 AAC: RGC1S60D61GGEP	85 AAC: RGC1S60D90GGEP
600 VAC, 1200 V _P , U-type	43 AAC: RGC1S60D41GGUP	65 AAC: RGC1S60D61GGUP	

GG = box clamps for control terminals, box clamps for power terminals

CARLO GAVAZZI Automation Components. Specifications are subject to change without notice. Illustrations are for example only.

Solid state contactors, 1-phase

DIN-rail mounting - Soft start switching

Types	RGC1P..K.. 30 AAC	RGC1P..K.. 43 AAC	RGC1P..K.. 63 AAC
Single-phase, solid state relay with integrated heatsink, with integrated overvoltage protection, LED for control and load status indication, IP20 protection, Rated isolation voltage ≥ 4000 Vrms, 100 kArms short circuit current rating.			
Dimensions HxWxD (mm)	110 x 35.8 x 104	110 x 35.8 x 104	110 x 72 x 126
Features	DC control input solid state contactor with soft starting feature for short wave infrared heaters	DC control input solid state contactor with soft starting feature for short wave infrared heaters	DC control input solid state contactor with soft starting feature for short wave infrared heaters
Supply specifications			
Supply voltage	24 VDC -15%, +20% 24 VAC -15%, +15%	24 VDC -15%, +20% 24 VAC -15%, +15%	24 VDC -15%, +20% 24 VAC -15%, +15%
Max. supply current	30 mA	30 mA	30 mA
Control specifications			
Control input	19.2 - 28.8 VDC	19.2 - 28.8 VDC	19.2 - 28.8 VDC
Input impedance	100 k Ω	100 k Ω	100 k Ω
Output specifications			
Rated operational current AC-51 @ 40°C	30 AAC	43 AAC	63 AAC
Minimum operational current	250 mAAC	500 mAAC	500 mAAC
Non rep. surge current (I _{tsm}) (t=10 ms)	600 Ap	1900 Ap	1900 Ap
I ² t for fusing (t=10 ms)	1800 A ² s	18000 A ² s	18000 A ² s
Max. Off-state leakage current	5 mAAC	5 mAAC	5 mAAC
Critical dV/dt (@ T _j init=40°C)	1000 V/ μ s	1000 V/ μ s	1000 V/ μ s
General specifications			
Operational voltage range	85 - 265 VAC [RGC1P23..] 190 - 550 VAC [RGC1P48..] 410 - 660 VAC [RGC1P60..]	85 - 265 VAC [RGC1P23..] 190 - 550 VAC [RGC1P48..] 410 - 660 VAC [RGC1P60..]	85 - 265 VAC [RGC1P23..] 190 - 550 VAC [RGC1P48..] 410 - 660 VAC [RGC1P60..]
Blocking voltage	800 V _P [RGC1P23..] 1200 V _P [RGC1P48..] 1200 V _P [RGC1P60..]	800 V _P [RGC1P23..] 1200 V _P [RGC1P48..] 1200 V _P [RGC1P60..]	800 V _P [RGC1P23..] 1200 V _P [RGC1P48..] 1200 V _P [RGC1P60..]
Power factor	> 0.7	> 0.7	> 0.7
Terminals	Screw with captive clamp	Box clamp	Box clamp
Operating temperature	-40°C to +70°C	-40°C to +70°C	-40°C to +70°C
Approvals/Marks	CE - UL - cUL - EAC	CE - UL - cUL - EAC	CE - UL - cUL - EAC
References			
External supply 24 VDC/AC			
Operational output 85 - 265 VAC	RGC1P23K30ED	RGC1P23K42ED	RGC1P23K62ED
Operational output 190 - 550 VAC	RGC1P48K30ED	RGC1P48K42ED	RGC1P48K62ED
Operational output 410 - 660 VAC	RGC1P60K30ED	RGC1P60K42ED	RGC1P60K62ED

Solid state contactors, 1-phase

DIN-rail mounting - Proportional controllers

Types	RGC1P..AA.. / V.. 12 AAC	RGC1P..AA.. / V.. 30 AAC	RGC1P..AA.. / V.. 43 AAC	RGC1P..AA.. / V.. 50 / 63 AAC
Single-phase, solid state relay with integrated heatsink, with integrated overvoltage protection, LED for control and load status indication, IP20 protection, rated isolation voltage ≥ 4000 Vrms, 100 kArms short circuit current rating.				

Dimensions HxWxD (mm)	106 x 35.8 x 65	110 x 35.8 x 104	110 x 35.8 x 104	110 x 72 x 126
Features	Analogue input (current or voltage), selectable modes for output switching - phase angle, full cycle distributed firing, advanced full cycle and soft starting	Analogue input (current or voltage), selectable modes for output switching - phase angle, full cycle distributed firing, advanced full cycle and soft starting	Analogue input (current or voltage), selectable modes for output switching - phase angle, full cycle distributed firing, advanced full cycle and soft starting	Analogue input (current or voltage), selectable modes for output switching - phase angle, full cycle distributed firing, advanced full cycle and soft starting

Supply specifications

Supply voltage	24 VDC -15%, +20% [RG..V..ED] 24 VAC -15%, +15% [RG..V..ED] 90-250 VAC [RG..V..EA]	24 VDC -15%, +20% [RG..V..ED] 24 VAC -15%, +15% [RG..V..ED] 90-250 VAC [RG..V..EA]	24 VDC -15%, +20% [RG..V..ED] 24 VAC -15%, +15% [RG..V..ED] 90-250 VAC [RG..V..EA]	24 VDC -15%, +20% [RG..V..ED] 24 VAC -15%, +15% [RG..V..ED] 90-250 VAC [RG..V..EA]
Max. supply current	30 mA [RG..V..ED] 14 mA [RG..V..EA]	30 mA [RG..V..ED] 14 mA [RG..V..EA]	30 mA [RG..V..ED] 14 mA [RG..V..EA]	30 mA [RG..V..ED] 14 mA [RG..V..EA]

Control specifications

Control input range	4-20 mA [RG..AA..] 0-10 V, 0-5 V, 1-5 V, POT [RG..V..]	4-20 mA [RG..AA..] 0-10 V, 0-5 V, 1-5 V, POT [RG..V..]	4-20 mA [RG..AA..] 0-10 V, 0-5 V, 1-5 V, POT [RG..V..]	4-20 mA [RG..AA..] 0-10 V, 0-5 V, 1-5 V, POT [RG..V..]
Input impedance	500 Ω [RG..AA..] 100 k Ω [RG..V..]	500 Ω [RG..AA..] 100 k Ω [RG..V..]	500 Ω [RG..AA..] 100 k Ω [RG..V..]	500 Ω [RG..AA..] 100 k Ω [RG..V..]

Output specifications

Rated operational current AC-51 @ 40°C	15 AAC	30 AAC	43 AAC	50 AAC [RG..50] 63 AAC [RG..62]
Minimum operational current	250 mAAC	250 mAAC	500 mAAC	500 mAAC
Non rep. surge current (I _{tsm}) (t=10 ms)	600 AP	600 AP	1900 AP	800 AP [RG..50] 1900 AP [RG..62]
I ² t for fusing (t=10 ms)	1800 A ² s	1800 A ² s	18000 A ² s	3200 A ² s [RG..50] 18000 A ² s [RG..62]
Max. Off-state leakage current	5 mAAC	5 mAAC	5 mAAC	5 mAAC
Critical dV/dt (@ T _j init=40°C)	1000 V/ μ s	1000 V/ μ s	1000 V/ μ s	1000 V/ μ s

General specifications





Operational voltage range	85 - 265 VAC [RGC1P23..] 190 - 550 VAC [RGC1P48..]	85 - 265 VAC [RGC1P23..] 190 - 550 VAC [RGC1P48..] 410 - 660 VAC [RGC1P60..]	85 - 265 VAC [RGC1P23..] 190 - 550 VAC [RGC1P48..] 410 - 660 VAC [RGC1P60..]	85 - 265 VAC [RGC1P23..] 190 - 550 VAC [RGC1P48..] 410 - 660 VAC [RGC1P60..]
Blocking voltage	800 VP [RGC1P23..] 1200 VP [RGC1P48..]	800 VP [RGC1P23..] 1200 VP [RGC1P48..] 1200 VP [RGC1P60..]	800 VP [RGC1P23..] 1200 VP [RGC1P48..] 1200 VP [RGC1P60..]	800 VP [RGC1P23..] 1200 VP [RGC1P48..] 1200 VP [RGC1P60..]
Power factor	> 0.7	> 0.7	> 0.7	> 0.7
Terminals	Screw with captive clamp	Screw with captive clamp	Box clamp	Box clamp
Operating temperature	-40°C to +70°C	-40°C to +70°C	-40°C to +70°C	-40°C to +70°C
Approvals/Marks	CE - UL - cUL - EAC	CE - UL - cUL - EAC	CE - UL - cUL - EAC	CE - UL - cUL - EAC

References

Control input				
4-20 mA	RGC1PyyAA12E	RGC1PxxAA30E	RGC1PxxAA42E	50 AAC: RGC1PyyAA50E 63 AAC: RGC1PxxAA62E
0-10 VDC, 0-5 VDC, 1-5 VDC, POT	RGC1PyyV12ED	RGC1PxxV30ED	RGC1PxxV42ED	50 AAC: RGC1PyyV50ED 63 AAC: RGC1PxxV62ED
External supply 24 VDC/AC	RGC1PyyV12EA	RGC1PxxV30EA	RGC1PxxV42EA	63 AAC: RGC1PxxV62EA

xx = 23 for operational voltage range 85 - 265 VAC
48 for operational voltage range 190 - 550 VAC
60 for operational voltage range 410 - 660 VAC
yy = 23 for operational voltage range 85 - 265 VAC
48 for operational voltage range 190 - 550 VAC

Solid state relays with communication interface

	NRG controller Modbus RTU	NRG controller PROFINET	NRG controller EtherNet/IP™	NRG BUS cables
Types	NRGC	NRGC-PN	NRGC-EIP	RCRGN..
<p>Solid state solutions with real-time monitoring. The NRG controller and NRG BUS cables are required for the operation of the NRG solid state relays.</p>    				
Dimensions HxWxD (mm)	90 x 38.5 x 64 (without plugs) 107 x 38.5 x 64 (with plugs)	90 x 38.5 x 64 (without plugs) 107 x 38.5 x 64 (with plug)	90 x 38.5 x 64 (without plugs) 107 x 38.5 x 64 (with plug)	
	Controller of the NRG BUS chain with Modbus RTU over RS485 interface. The NRGC is the master of the BUS chain when configuration is required for the NRG SSRs. It acts as a gateway when the PLC needs to access the NRG SSRs. Each NRGC can handle a maximum of 48 RG..D..N (NRG SSRs with external control) or 32 RG..CM..N (NRGS SSRs with control via bus)	Controller of the NRG BUS chain with PROFINET interface. The NRGC-PN auto addresses the NRG solid state relays on startup. Each NRGC-PN can handle a maximum of 32 NRG solid state relays	Controller of the NRG BUS chain with EtherNet/IP interface. The NRGC-EIP auto addresses the NRG solid state relays on startup. Each NRGC-EIP can handle a maximum of 32 NRG solid state relays	Terminated proprietary cables for the NRG internal BUS connecting respective RG..N solid state relays to the NRG controller. The BUS terminator terminates the internal BUS
Supply specifications				
Supply voltage	19.2 - 32 VDC	19.2 - 32 VDC	19.2 - 32 VDC	
Power consumption	<12 W	<12 W	<12 W	
Auxiliary output specifications				
Relay output	EMR, 3 pins (1 Form C)			
Relay output function	Configurable as an auxiliary output or an alarm output. Default is set as an alarm output (operates in case of NRGC related alarms)			
Relay output ratings	2 A, 250 VAC / 30 VDC			
Alarm specifications				
Alarm output	Red LED, Relay output if set to operate as an alarm output, status register of the NRGC	Red LED, Diagnostics messages via the PROFINET Diagnostic System	Red LED, Diagnostics messages via EtherNet/IP implicit messages	
General specifications				
Communication protocol	Modbus RTU, 2-wire half duplex	PROFINET	EtherNet/IP	
Communication parameters	Baudrate: 115200 bits/s (selectable 9600, 19200, 38400, 57600)	GSDML file	EDS file	
Physical interface	2x RJ45 plugs	2x RJ45 plugs ports (X1, X2) 100 Mbit, full duplex	2x RJ45 plugs ports (X1, X2) 100 Mbit, full duplex	
Approvals/Marks	CE - cULus - EAC	CE - cULus - EAC - PI certified	CE - cULus - EAC - ODVA conformant	
References				
NRG controller	NRGC	NRGC-PN	NRGC-EIP	
NRG BUS cables				10 cm: RCRGN-010-2 75 cm: RCRGN-075-2 150 cm: RCRGN-150-2 350 cm: RCRGN-350-2 500 cm: RCRGN-500-2
NRG internal BUS termination				RGN-TERMRES*

* 1x RGN-TERMRES is provided with each NRG Controller

Solid state relays with communication interface, 1-phase

NRG Solid state relays

Types	RGS..N 50/90 AAC	RGC..N 25/30/37 AAC	RGC..N 43/65 AAC
-------	---------------------	------------------------	---------------------

Switching components within the NRG system; Single-phase, AC operating frequency 45-65 Hz, rated isolation ≥ 4000 Vrms, IP20 protection, 100 kArms short circuit current rating according to UL508, integrated varistor on output.



Dimensions HxWxD (mm)	90 x 17.8 x 82	110 x 17.8 x 134	110 x 35 x 172 [RGC..42..] 110 x 70 x 172 [RGC..62..]
-----------------------	----------------	------------------	---

Features Solid state relays with integrated monitoring and a communication interface to provide real time data through an internal BUS: Current, Voltage, Frequency, Power, Energy consumption, SSR running hours and Load running hours. Interface to the PLC is done through the **NRGC**. RG..D..N versions are switched via an external voltage. A max. of 48 RG..D..Ns can be connected to 1x NRGC. RG..CM..N versions can be switched via the BUS as default or through an external voltage. RG..CM..N allows selection of switching mode in ON/OFF, Full cycle, Advanced full cycle or Burst. A max. of 32 RG..CM..Ns can be connected to 1x NRGC.

Control specifications

Control input range	4-32 VDC	4-32 VDC	4-32 VDC
Max. input current	12.5 mA	12.5 mA	12.5 mA

Supply specifications

Supply voltage Provided through internal BUS using cables RCRGN...

Alarm specifications

Alarm output Red LED on the RG..N, alarm presence is identified through the status register of the solid state relay. Alarms that can be detected include: load deviation, system failure (mains loss, load loss, SSR open circuit), SSR short circuit, current out of range, voltage out of range, frequency out of range, over-temperature protection, communication and internal errors.

Output specifications

Rated operational current			
AC 51 @ Ta=40°C	50 AAC [RGS..50..] 90 AAC [RGS..92..]	25 AAC [RGC..25KEN] 30 AAC [RGC..32KEN] 37 AAC [RGC..32GEN]	43 AAC [RGC..42..] 65 AAC [RGC..62..]
Min. operational current	250 mAAC [RGS..50..] 500 mAAC [RGS..92..]	250 mAAC [RGC..25..] 500 mAAC [RGC..32..]	500 mAAC
Non-rep. surge current (t=10 ms)	600 Ap [RGS..50..] 1900 Ap [RGS..92..]	600 Ap [RGC..25..] 1900 Ap [RGC..32..]	1900 Ap
Off-state leakage current	< 5 mAAC	< 5 mAAC	< 5 mAAC
I ² t for fusing (t=10 ms)	1800 A ² s [RGS..50..] 18000 A ² s [RGS..92..]	1800 A ² s [RGC..25..] 18000 A ² s [RGC..32..]	18000 A ² s
Critical dV/dt off-state	1000 V/μs	1000 V/μs	1000 V/μs

General specifications

Operational voltage range	42 - 600 VAC +10%	42 - 600 VAC +10%	42 - 600 VAC +10%
Blocking voltage	1200 Vr	1200 Vr	1200 Vr
Power factor	≥ 0.9	≥ 0.9	≥ 0.9
Operating temperature	-20°C to +65°C	-20°C to +65°C	-20°C to +65°C
Output terminals	Screw [RG..KEN] Box clamp [RG..GEN]	Screw [RG..KEN] Box clamp [RG..GEN]	Box clamp
Approvals/Marks	CE - UR - CSA - EAC	CE - cULus - EAC	CE - cULus - EAC

References

600 VAC, 1200 Vr, Screw	50 AAC: RGS1A60X50KEN	25 AAC: RGC1A60X25KEN	
	90 AAC: RGS1A60X92KEN	30 AAC: RGC1A60X32KEN	
600 VAC, 1200 Vr, Box clamps	90 AAC: RGS1A60X92GEN	37 AAC: RGC1A60X32GEN	43 AAC: RGC1A60X42GEN 65 AAC: RGC1A60X62GEN

X = 'D' for versions with external control only. Compatible with NRGC only
X = 'CM' for versions that can be switched via the communication interface or optionally through external control. Compatible with NRGC, NRGC-PN, NRGC-EIP

Solid state contactors, 45 mm, 3-phase

DIN-rail mounting - AC output, 3 poles

Types

RGCM3A..15..
15 AAC / 2.2 kW

Semiconductor contactors with integrated heatsink.
AC operating frequency range
45-65 Hz.
Rated isolation voltage
≥4000 Vrms.



Dimensions HxWxD (mm)

105 x 45 x 105

Features

45 mm solid state contactor, enclosed heatsink, integrated varistors for over-voltage protection, 5 kArms SCCR, screw with clamp for power connection

Control specifications

Control input range

5-32 VDC [RGC..D.]
20-275 VAC, 24-190 VDC [RGC..A.]

Input current @
max. control voltage

31.5 mADC [RG..D.]
19 mAAC [RG..A.]

Output specifications

Rated operational current
AC-51 @ Ta=40°C

15.5 AAC

AC-53a @ Ta=40°C

5.8 AAC

Motor rating

2.2 kW @ 400 VAC
3 HP @ 600 VAC

Minimum operational current

250 mAAC

Non. rep. surge current
I_{tsm} (t=10 ms)

600 AP

I²t for fusing (t=10 ms)

1800 A²s

Off-state leakage current

3 mAAC

Critical dV/dt (@ T_j init=40°C)

1000 V/μs

General specifications

Operational voltage range

42-600 VAC +10%

Blocking voltage

1200 V_P

Power factor

≥ 0.5 at rated voltage

Operating temperature

-40°C to +70°C

Approvals/Marks

CE - cULus -EAC

References

DC control voltage





RGCM3A60D15GKE

AC control voltage

RGCM3A60A15GKE



Solid state contactors, 3-phase

DIN-rail mounting - AC output, 2 + 1 poles

Types	RGC2A..10.. 10 AAC	RGC2A..25.. 27 AAC	RGC2A..40.. 40 AAC	RGC2A..75.. 75 AAC
Semiconductor contactors with integrated heatsink, AC operating frequency range 45-65 Hz. Rated isolation voltage 4000 Vrms.				
Dimensions HxWxD (mm)	106 x 54 x 65	110 x 54 x 103	110 x 72 x 126	141 x 72 x 141 (with fan)
Features	54 mm solid state contactor, integrated varistors for over-voltage protection, 100 kArms SCCR, screw with clamp for power connection	54 mm solid state contactor, integrated varistors for over-voltage protection, 100 kArms SCCR, screw with clamp for power connection	72 mm solid state contactor, integrated varistors for over-voltage protection, 100 kArms SCCR, box clamp for power connection	72 mm solid state contactor, integrated overheat protection with EMR alarm output, 100 kArms SCCR, box clamp for power connection
Input specifications				
Control input range	5-32 VDC [RGC..D.] 20-275 VAC, 24-190 VDC [RGC..A.]	5-32 VDC [RGC..D.] 20-275 VAC, 24-190 VDC [RGC..A.]	5-32 VDC [RGC..D.] 20-275 VAC, 24-190 VDC [RGC..A.]	5-32 VDC [RG..D..DF] 5-32 VDC [RG..D..AF] 20-275 VAC [RG..A..AF]
Input current @ max. control voltage	31.5 mADC [RG..D.] 19 mAAC [RG..A.]	31.5 mADC [RG..D.] 19 mAAC [RG..A.]	31.5 mADC [RG..D.] 19 mAAC [RG..A.]	12.5 mADC [RG..D..DF] 5.5 mADC [RG..D..AF] 4.3 mAAC [RG..A..AF]
External supply voltage				24 VDC [RG..D..DF] 90-250 VAC [RG..D..AF] 90-250 VAC [RG..A..AF]
Max. supply current				150 mADC [RG..D..DF] 80 mADC [RG..D..AF] 80 mAAC [RG..A..AF]
Alarm specifications				
Alarm output				EMR: 2 A 230 VAC / 30 VDC
Alarm condition				Over Temperature
Output specifications				
Rated operational current AC-51 @ Ta=40°C	10 AAC	27 AAC	40 AAC	75 AAC
AC-53a @ Ta=40°C	5 AAC	11.5 AAC	16.5 AAC	28 AAC
Motor rating	1.5 kW @ 400 VAC 3 HP @ 600 VAC VAC	5.5 kW @ 400 VAC 10 HP @ 600 VAC	7.5 kW @ 400 VAC 15 HP @ 600 VAC	11 kW @ 400 VAC 25 HP @ 600 VAC
Minimum operational current	250 mAAC	250 mAAC	400 mAAC	500 mAAC
Non. rep. surge current Iism (t=10 ms)	600 Ap	600 Ap	1150 Ap	1750 Ap
I ² t for fusing (t=10 ms)	1800 A ² s	1800 A ² s	6600 A ² s	15000 A ² s
General specifications				
Operational voltage range	42-600 VAC +10%	42-220 VAC +10% [RG..22.] 42-600 VAC +10% [RG..60.]	42-600 VAC +10%	42-600 VAC +10%
Blocking voltage	1200 Vp	800 Vp [RG..22.] 1200 Vp [RG..60.]	1200 Vp	1200 Vp
Power factor	≥ 0.5 at rated voltage	≥ 0.5 at rated voltage	≥ 0.5 at rated voltage	≥ 0.5 at rated voltage
Operating temperature	-40°C to +80°C	-40°C to +80°C	-40°C to +80°C	-40°C to +70°C [RG..DF] -40°C to +60°C [RG...AF]
Approvals/Marks	CE - cULus - EAC - VDE - CCC	CE - cULus - EAC - CCC	CE - cULus - EAC - CCC	CE - cULus - EAC - CCC
References				
DC control voltage				
220 VAC, 800 Vp		RGC2A22D25KKE		
600 VAC, 1200 Vp	RGC2A60D10KKE	RGC2A60D25KKE	RGC2A60D40KGE	
AC/DC control voltage				
220 VAC, 800 Vp		RGC2A22A25KKE		
600 VAC, 1200 Vp	RGC2A60A10KKE	RGC2A60A25KKE	RGC2A60A40KGE	
DC control voltage, DC external supply				RGC2A60D75GGEDF
DC control voltage, AC external supply				RGC2A60D75GGEAF
AC control voltage, AC external supply				RGC2A60A75GGEAF



Solid state contactors, 3-phase

DIN-rail mounting - AC output with monitoring, 2 + 1 poles



Types	RGC2A..25..M 27 AAC	RGC2A..40..M 40 AAC	RGC2A..75..FM 75 AAC
Semiconductor contactors with integrated heatsink, AC operating frequency 45-65 Hz. Rated isolation voltage output to heatsink of 4000 Vrms, 100 kArms Short Circuit Current Rating.			
Dimensions HxWxD (mm)	110 x 54 x 118	110 x 72 x 141	141 x 72 x 141 (with fan)
Features	54 mm solid state contactor, EMR alarm output and electronic auxiliary output, screw with clamp for power connection	72 mm solid state contactor, EMR alarm output and electronic auxiliary output, box clamp for power connection	72 mm solid state contactor, EMR alarm output and electronic auxiliary output, box clamp for power connection
Input specifications			
Control input range	5-32 VDC [RG..D..DM] 5-32 VDC [RG..D..AM] 20-275 VAC [RG..A..AM]	5-32 VDC [RG..D..DM] 5-32 VDC [RG..D..AM] 20-275 VAC [RG..A..AM]	5-32 VDC [RG..D..DFM] 5-32 VDC [RG..D..AFM] 20-275 VAC [RG..A..AFM]
Control current @ max. control voltage	12.5 mADC [RG..D..DM] 5.5 mADC [RG..D..AM] 4.3 mAAC [RG..A..AM]	12.5 mADC [RG..D..DM] 5.5 mADC [RG..D..AM] 4.3 mAAC [RG..A..AM]	12.5 mADC [RG..D..DFM] 5.5 mADC [RG..D..AFM] 4.3 mAAC [RG..A..AFM]
External supply voltage	24 VDC [RG..D..DM] 90-250 VAC [RG..D..AM] 90-250 VAC [RG..A..AM]	24 VDC [RG..D..DM] 90-250 VAC [RG..D..AM] 90-250 VAC [RG..A..AM]	24 VDC [RG..D..DFM] 90-250 VAC [RG..D..AFM] 90-250 VAC [RG..A..AFM]
Max. supply current	60 mADC [RG..D..DM] 60 mAAC [RG..D..AM] 60 mAAC [RG..A..AM]	60 mADC [RG..D..DM] 60 mAAC [RG..D..AM] 60 mAAC [RG..A..AM]	150 mADC [RG..D..DFM] 80 mAAC [RG..D..AFM] 80 mAAC [RG..A..AFM]
Alarm specifications			
Alarm output	EMR; 2 A 250 VAC / 30 VDC	EMR; 2 A 250 VAC / 30 VDC	EMR; 2 A 250 VAC / 30 VDC
Alarm condition	Mains loss, Load loss, SSR open cct., SSR short cct., SSR over temperature	Mains loss, Load loss, SSR open cct., SSR short cct., SSR over temperature	Mains loss, Load loss, SSR open cct., SSR short cct., SSR over temperature
Output specifications			
Rated operational current AC-51 @ Ta=40°C	27 AAC	40 AAC	75 AAC
Minimum operational current	250 mAAC	400 mAAC	500 mAAC
Non. rep. surge current I _{tsm} (t=10 ms)	600 Ap	1150 Ap	1750 Ap
I ² t for fusing (t=10 ms)	1800 A ² s	6600 A ² s	15000 A ² s
Off-state leakage current	5 mAAC	5 mAAC	5 mAAC
General specifications			
Operational voltage range	90-600 VAC +10%	90-600 VAC +10%	90-600 VAC +10%
Blocking voltage	1200 Vp	1200 Vp	1200 Vp
Operating temperature	-40°C to +80°C [RG...DM] -40°C to +60°C [RG...AM]	-40°C to +80°C [RG...DM] -40°C to +60°C [RG...AM]	-40°C to +70°C [RG...DFM] -40°C to +60°C [RG...AFM]
Approvals/Marks	CE - cULus - EAC - CCC	CE - cULus - EAC - CCC	CE - cULus - EAC - CCC
References			
600 VAC, 1200 Vp			
DC control voltage, DC external supply	RGC2A60D25GKEDM	RGC2A60D40GGEDM	RGC2A60D75GGEDFM
DC control voltage, AC external supply	RGC2A60D25GKEAM	RGC2A60D40GGEAM	RGC2A60D75GGEAFM
AC control voltage, AC external supply	RGC2A60A25GKEAM	RGC2A60A40GGEAM	RGC2A60A75GGEAFM

Solid state contactors, 3-phase

DIN-rail mounting - AC output, 3 poles

Types	RGC3A..10.. 10 AAC	RGC3A..20.. 20 AAC	RGC3A..25.. / 30.. 28/30 AAC
Semiconductor contactors with integrated heatsink, AC operating frequency 45-65 Hz. Rated isolation voltage output to heatsink of 4000 Vrms.			
Dimensions HxWxD (mm)	110 x 54 x 63.5	110 x 54 x 103	110 x 72 x 126
Features	54 mm solid state contactor, integrated varistors for over-voltage protection, 100 kArms SCCR, screw with clamp for power connection	54 mm solid state contactor, integrated varistors for over-voltage protection, 100 kArms SCCR, screw with clamp for power connection	72 mm solid state contactor, integrated varistors for over-voltage protection, 100 kArms SCCR, screw with clamp or box clamp for power connection
Input specifications			
Control input range	5-32 VDC [RGC..D.] 20-275 VAC, 24-190 VDC [RGC..A.]	5-32 VDC [RGC..D.] 20-275 VAC, 24-190 VDC [RGC..A.]	5-32 VDC [RGC..D.] 20-275 VAC, 24-190 VDC [RGC..A.]
Input current @ max. control voltage	31.5 mADC [RG..D.] 19 mAAC [RG..A.]	31.5 mADC [RG..D.] 19 mAAC [RG..A.]	31.5 mADC [RG..D.] 19 mAAC [RG..A.]
Output specifications			
Rated operational current AC-51 @ Ta=40°C	10 AAC	20 AAC	28 AAC [RGC3..25] 30 AAC [RGC3..30]
AC-53a @ Ta=40°C	5 AAC	10 AAC	11 AAC [RGC3..25] 14 AAC [RGC3..30]
Motor rating	1.5 kW @ 400 VAC 3 HP @ 600 VAC	4 kW @ 400 VAC 10 HP @ 600 VAC	4 kW @ 400 VAC [RGC3..25] 5.5 kW @ 400 VAC [RGC3..30] 10 HP @ 600 VAC [RGC3..25] 15 HP @ 600 VAC [RGC3..30]
Minimum operational current	250 mAAC	250 mAAC	250 mAAC [RGC3..25] 400 mAAC [RGC3..30]
Non. rep. surge current I _{tsm} (t=10 ms)	600 Ap	600 Ap	600 Ap [RGC3..25] 1150 Ap [RGC3..30]
I ² t for fusing (t=10 ms)	1800 A ² s	1800 A ² s	1800 A ² s [RGC3..25] 6600 A ² s [RGC3..30]
Off-state leakage current	5 mAAC	5 mAAC	5 mAAC
Critical dV/dt (@ T _j init=40°C)	1000 V/μs	1000 V/μs	1000 V/μs
General specifications			
Operational voltage range	42-220 VAC + 10% [RG..22.] 42-600 VAC +10% [RG..60.]	42-220 VAC + 10% [RG..22.] 42-600 VAC +10% [RG..60.]	42-600 VAC +10%
Blocking voltage	800 V _p [RG..22.] 1200 V _p [RG..60.]	800 V _p [RG..22.] 1200 V _p [RG..60.]	1200 V _p
Power factor	≥ 0.5 at rated voltage	≥ 0.5 at rated voltage	≥ 0.5 at rated voltage
Operating temperature	-40°C to +80°C	-40°C to +80°C	-40°C to +80°C
Approvals/Marks	CE - cULus - EAC - VDE - CCC	CE - cULus - EAC - CCC	CE - cULus - EAC - CCC
References			
DC control voltage			
220 VAC, 800 V _p	RGC3A22D10KKE	RGC3A22D20KKE	
600 VAC, 1200 V _p	RGC3A60D10KKE	RGC3A60D20KKE	28 AAC: RGC3A60D25KKE 30 AAC: RGC3A60D30KGE
AC/DC control voltage			
220 VAC, 800 V _p	RGC3A22A10KKE	RGC3A22A20KKE	
600 VAC, 1200 V _p	RGC3A60A10KKE	RGC3A60A20KKE	28 AAC: RGC3A60A25KKE 30 AAC: RGC3A60A30KGE





Solid state contactors, 3-phase

	DIN-rail mounting - AC output, 3 poles		Panel mounting - AC output, 3 poles
Types	RGC3A..40..F 42 AAC	RGC3A..65..F 66 AAC	RGC3A..48 48 AAC
Semiconductor contactors with integrated heatsink, AC operating frequency 45-65 Hz. Rated isolation voltage output to heatsink of 4000 Vrms, 100 kArms short circuit current rating.			
Dimensions HxWxD (mm)	135 x 54 x 118 (with fan)	141 x 72 x 141 (with fan)	175 x 157 x 119
Features	54 mm solid state contactor + fan, integrated overheat protection with EMR alarm output, box clamp for power connection	72 mm solid state contactor + fan, integrated overheat protection with EMR alarm output, box clamp for power connection	157 mm solid state contactor, integrated varistors for over-voltage protection, 100 kArms SCCR, box clamp for power connection
Input specifications			
Control input range	5-32 VDC [RG..D..DF] 20-275 VAC [RG..A..AF]	5-32 VDC [RG..D..DF] 5-32 VDC [RG..D..AF] 20-275 VAC [RG..A..AF]	5-32 VDC [RG..D] 20-275 VAC, 24-190 VDC [RG..A]
Input current @ max. control voltage	12.5 mADC [RG..D..DF] 4.3 mAAC [RG..A..AF]	12.5 mADC [RG..D..DF] 5.5 mADC [RG..D..AF] 4.3 mAAC [RG..A..AF]	31.5 mADC [RG..D] 19 mAAC [RG..A]
External supply voltage	24 VDC [RG..D..DF] 90-250 VAC [RG..A..AF]	24 VDC [RG..D..DF] 90-250 VAC [RG..D..AF] 90-250 VAC [RG..A..AF]	
Max. supply current	150 mADC [RG..D..DF] 80 mAAC [RG..A..AF]	150 mADC [RG..D..DF] 80 mAAC [RG..D..AF] 80 mAAC [RG..A..AF]	
Alarm specifications			
Alarm output	EMR; 2 A 250 VAC / 30 VDC	EMR; 2 A 250 VAC / 30 VDC	
Alarm condition	SSR Over temperature	SSR Over temperature	
Output specifications			
Rated operational current AC-51 @ Ta=40°C	42 AAC	66 AAC	48 AAC
AC-53a @ Ta=40°C	17 AAC	25 AAC	23 AAC
Motor rating	7.5 kW @ 400 VAC 15 HP @ 600 VAC	11 kW @ 400 VAC 25 HP @ 600 VAC	11 kW @ 400 VAC 25 HP @ 600 VAC
Minimum operational current	400 mAAC	500 mAAC	500 mAAC
Non. rep. surge current I _{tsm} (t=10ms)	1150 A _p	1750 A _p	1750 A _p
I ² t for fusing (t=10 ms)	6600 A ² s	15000 A ² s	15000 A ² s
Off-state leakage current	5 mAAC	5 mAAC	5 mAAC
Critical dV/dt (@ T _j init=40°C)	1000 V/μs	1000 V/μs	1000 V/μs
General specifications			
Operational voltage range	42-600 VAC +10%	42-600 VAC +10%	42-600 VAC +10%
Blocking voltage	1200 V _p	1200 V _p	1200 V _p
Power factor	≥ 0.5 at rated voltage	≥ 0.5 at rated voltage	≥ 0.5 at rated voltage
Operating temperature	-40°C to +70°C [RG..D..DF] -40°C to +60°C [RG..A..AF]	-40°C to +70°C [RG..D..DF] -40°C to +60°C [RG..A..AF]	-40°C to +80°C
Approvals/Marks	CE - cULus - EAC - CCC	CE - cULus - EAC - CCC	CE - cULus - EAC
References			
600 VAC, 1200 V _p			
DC control voltage, DC external supply	RGC3A60D40GGEDF	RGC3A60D65GGEDF	
DC control voltage, AC external supply		RGC3A60D65GGEAF	
AC control voltage, AC external supply	RGC3A60A40GGEAF	RGC3A60A65GGEAF	
DC control voltage			RGC3A60D48KGE
AC control voltage			RGC3A60A48KGE

Solid state contactors, 3-phase

**DIN-rail mounting -
AC output with monitoring, 3 poles**

**Panel mounting
- AC output with
monitoring, 3 poles**

Types	RGC3A..20..M 20 AAC	RGC3A..25/30..M 28/30 AAC	RGC3A..65..FM 66 AAC	RGC3A..48..M 48 AAC
Semiconductor contactors with integrated heatsink, AC operating frequency 45-65 Hz. Rated isolation voltage output to heatsink of 4000 Vrms, 100 kArms SCCR.				
Dimensions HxWxD (mm)	110 x 54 x 118	110 x 72 x 141	141 x 72 x 141 (with fan)	175 x 157 x 119
Features	54 mm solid state contactor, EMR alarm output and electronic auxiliary output, screw with clamp for power connection	72 mm solid state contactor, EMR alarm output and electronic auxiliary output, screw with clamp or box clamp for power connection	72 mm solid state contactor + fan, EMR alarm output and electronic auxiliary output, box clamp for power connection	157 mm solid state contactor, EMR alarm output and electronic auxiliary output, box clamp for power connection

Input specifications

Control input range	5-32 VDC [RG..D..DM] 5-32 VDC [RG..D..AM] 20-275 VAC [RG..A..AM]	5-32 VDC [RG..D..DM] 5-32 VDC [RG..D..AM] 20-275 VAC [RG..A..AM]	5-32 VDC [RG..D..DFM] 5-32 VDC [RG..D..AFM] 20-275 VAC [RG..A..AFM]	5-32 VDC [RG..D..D] 20-275 VAC [RG..A..A]
Control current @ max. control voltage	12.5 mADC [RG..D..DM] 5.5 mADC [RG..D..AM] 4.3 mAAC [RG..A..AM]	12.5 mADC [RG..D..DM] 5.5 mADC [RG..D..AM] 4.3 mAAC [RG..A..AM]	12.5 mADC [RG..D..DFM] 5.5 mADC [RG..D..AFM] 4.3 mAAC [RG..A..AFM]	12.5 mADC [RG..D..D] 4.3 mAAC [RG..A..A]
External supply voltage	24 VDC [RG..D..DM] 90-250 VAC [RG..D..AM] 90-250 VAC [RG..A..AM]	24 VDC [RG..D..DM] 90-250 VAC [RG..D..AM] 90-250 VAC [RG..A..AM]	24 VDC [RG..D..DFM] 90-250 VAC [RG..D..AFM] 90-250 VAC [RG..A..AFM]	24 VDC [RG..D..D] 90-250 VAC [RG..A..A]
Max. supply current	80 mADC [RG..D..DM] 60 mAAC [RG..D..AM] 60 mAAC [RG..A..AM]	80 mADC [RG..D..DM] 60 mAAC [RG..D..AM] 60 mAAC [RG..A..AM]	150 mADC [RG..D..DFM] 80 mAAC [RG..D..AFM] 80 mAAC [RG..A..AFM]	80 mADC [RG..D..D] 60 mAAC [RG..A..A]

Alarm specifications

Alarm output	EMR; 2 A 250 VAC / 30 VDC	EMR; 2 A 250 VAC / 30 VDC	EMR; 2 A 250 VAC / 30 VDC	EMR; 2 A 250 VAC / 30 VDC
Alarm condition	Mains loss, Load loss, SSR open cct., SSR short cct., SSR over temperature	Mains loss, Load loss, SSR open cct., SSR short cct., SSR over temperature	Mains loss, Load loss, SSR open cct., SSR short cct., SSR over temperature	Mains loss, Load loss, SSR Open cct., SSR Short cct., SSR Over temperature

Output specifications

Rated operational current AC-51 @ Ta=40°C	20 AAC	28 AAC [RGC3..25] 30 AAC [RGC3..30]	66 AAC	48 AAC
Minimum operational current	250 mAAC	250 mAAC [RGC3..25] 400 mAAC [RGC3..30]	500 mAAC	500 mAAC
Non. rep. surge current I _{tsm} (t=10 ms)	600 Ap	600 Ap [RGC3..25] 1150 Ap [RGC3..30]	1750 Ap	1750 Ap
Off-state leakage current	5 mAAC	5 mAAC	5 mAAC	5 mAAC
I ² t for fusing (t=10 ms)	1800 A ² s	1800 A ² s [RGC3..25] 6600 A ² s [RGC3..30]	15000 A ² s	15000 A ² s
Critical dV/dt (@ T _j init=40°C)	1000 V/μs	1000 V/μs	1000 V/μs	1000 V/μs

General specifications



Operational voltage range	90-600 VAC +10%	90-600 VAC +10%	90-600 VAC +10%	90-600 VAC +10%
Blocking voltage	1200 Vp	1200 Vp	1200 Vp	1200 Vp
Operating temperature	-40°C to +80°C [RG...DM] -40°C to +60°C [RG...AM]	-40°C to +80°C [RG...DM] -40°C to +60°C [RG...AM]	-40°C to +70°C [RG...DFM] -40°C to +60°C [RG...AFM]	-40°C to +80°C [RG...DM] -40°C to +60°C [RG...AM]
Approvals/Marks	CE - cULus - EAC - CCC	CE - cULus - EAC - CCC	CE - cULus - EAC - CCC	CE - cULus - EAC

References

DC control voltage, DC external supply	RGC3A60D20GKEDM	28 AAC: RGC3A60D25GKEDM 30 AAC: RGC3A60D30GGEDM	RGC3A60D65GGEDFM	RGC3A60D48GGEDM
DC control voltage, AC external supply	RGC3A60D20GKEAM	28 AAC: RGC3A60D25GKEAM 30 AAC: RGC3A60D30GGEAM	RGC3A60D65GGEAFM	
AC control voltage, AC external supply	RGC3A60A20GKEAM	28 AAC: RGC3A60A25GKEAM 30 AAC: RGC3A60A30GGEAM	RGC3A60A65GGEAFM	RGC3A60A48GGEAM



Solid state contactors, 3-phase

4-20 mA Proportional controllers, 2 + 1 poles

Types	RGC2P60AA15C1 15 AAC	RGC2P60AA25C1 27 AAC	RGC2P60AA40C1 40 AAC
3-phase semiconductor proportional controllers with integrated heatsink, AC operating frequency range 45-65 Hz. Rated isolation voltage 4000 Vrms, 100 kArms short circuit current rating.			
Dimensions HxWxD (mm)	110 x 54 x 103	110 x 54 x 103	110 x 72 x 126
Features	54 mm solid state contactor with integrated varistors for over-voltage protection, screw with clamp for power connection	54 mm solid state contactor with integrated varistors for over-voltage protection, screw with clamp for power connection	72 mm solid state contactor, integrated varistors for over-voltage protection, box clamp for power connection
Input specifications			
Control input	4-20 mADC	4-20 mADC	4-20 mADC
Voltage drop	<10 VDC @ 20 mADC	<10 VDC @ 20 mADC	<10 VDC @ 20 mADC
Types			
Switching mode	1 Full Cycle [RGC..C1..]	1 Full Cycle [RGC..C1..]	1 Full Cycle [RGC..C1..]
Output specifications			
Rated operational current AC-51 @ Ta=40°C	15 AAC	27 AAC	40 AAC
Minimum operational current	500 mAAC	500 mAAC	500 mAAC
Non. rep. surge current I _{tsm} (t=10 ms)	600 Ap	600 Ap	1150 Ap
I ² t for fusing (t=10 ms)	1800 A ² s	1800 A ² s	6600 A ² s
Off-state leakage current	5 mAAC	5 mAAC	5 mAAC
Critical dV/dt (@ T _j init=40°C)	1000 V/μs	1000 V/μs	1000 V/μs
General specifications			
Operational voltage range	180-600 VAC +10%	180-600 VAC +10%	180-600 VAC +10%
Blocking voltage	1200 Vp	1200 Vp	1200 Vp
Power factor	≥ 0.7 at rated voltage	≥ 0.7 at rated voltage	≥ 0.7 at rated voltage
Operating temperature	-40°C to +70°C	-40°C to +70°C	-40°C to +70°C
Approvals/Marks	CE - cULus - EAC -CCC	CE - cULus - EAC -CCC	CE - cULus - EAC -CCC
References			
Control Input:	4-20 mADC	4-20 mADC	4-20 mADC
1 Full Cycle	RGC2P60AA15C1	RGC2P60AA25C1	RGC2P60AA40C1



Solid state contactors, 3-phase

Proportional controllers with monitoring, 2 + 1 poles

Types	RGC2P..25..M 27 AAC	RGC2P..40..M 40 AAC	RGC2P..75..FM 75 AAC
Semiconductor contactors with integrated heatsink, AC operating frequency 45-65 Hz. Rated isolation voltage output to heatsink of 4000 Vrms, 100 kArms short circuit current rating.			
Dimensions HxWxD (mm)	110 x 54 x 118	110 x 72 x 141	141 x 72 x 141 (with fan)
Features	54 mm solid state contactor with integrated varistors for over-voltage protection, system monitoring, screw with clamp for power connection	72 mm solid state contactor with integrated varistors for over-voltage protection, system monitoring, box clamp for power connection	72 mm solid state contactor with fan and system monitoring, integrated varistors for over-voltage protection, box clamp for power connection
Input specifications			
Control input	0-20, 4-20, 12-20 mADC [RGC..I..] 0-10, 0-5, 1-5 VDC [RGC..V..] External potentiometer [RGC..V..]	0-20, 4-20, 12-20 mADC [RGC..I..] 0-10, 0-5, 1-5 VDC [RGC..V..] External potentiometer [RGC..V..]	0-20, 4-20, 12-20 mADC [RGC..I..] 0-10, 0-5, 1-5 VDC [RGC..V..] External potentiometer [RGC..V..]
Input impedance	<250 Ω [RGC..I..] 100 kΩ [RGC..V..]	<250 Ω [RGC..I..] 100 kΩ [RGC..V..]	<250 Ω [RGC..I..] 100 kΩ [RGC..V..]
External supply voltage	24 VDC/AC	24 VDC/AC	24 VDC/AC [RGC..DFM] 90-250 VAC [RGC..AFM]
Max. supply current	90 mADC/AC	90 mADC/AC	175 mADC/AC [RGC..DFM] 60 mAAC [RGC..AFM]
Alarm specifications			
Alarm output	EMR; 2 A 250 VAC / 30 VDC	EMR; 2 A 250 VAC / 30 VDC	EMR; 2 A 250 VAC / 30 VDC
Alarm condition	Mains loss, Load loss, SSR open cct., SSR short cct., SSR over temperature	Mains loss, Load loss, SSR open cct., SSR short cct., SSR over temperature	Mains loss, Load loss, SSR open cct., SSR short cct., SSR over temperature
Types			
Switching mode	1 Full Cycle [RGC..C1..] 4 Full Cycles [RGC..C4..]	1 Full Cycle [RGC..C1..] 4 Full Cycles [RGC..C4..]	1 Full Cycle [RGC..C1..] 4 Full Cycles [RGC..C4..]
Output specifications			
Rated operational current AC-51 @ Ta=40°C	27 AAC	40 AAC	75 AAC
Minimum operational current	500 mAAC	500 mAAC	500 mAAC
Non. rep. surge current I _{sm} (t=10 ms)	600 Ap	1150 Ap	1750 Ap
I ² t for fusing (t=10 ms)	1800 A ² s	6600 A ² s	15000 A ² s
Off-state leakage current	5 mAAC	5 mAAC	5 mAAC
Critical dV/dt (@ T _j init=40°C)	1000 V/μs	1000 V/μs	1000 V/μs
General specifications			
Operational voltage range	180-600 VAC +10%	180-600 VAC +10%	180-600 VAC +10%
Blocking voltage	1200 Vp	1200 Vp	1200 Vp
Power factor	≥ 0.7 at rated voltage	≥ 0.7 at rated voltage	≥ 0.7 at rated voltage
Operating temperature	-40°C to +70°C max. +60°C for 24 VAC supply	-40°C to +70°C max. +60°C for 24 VAC supply	-40°C to +70°C max. +60°C for 24 VAC supply
Approvals/Marks	CE - cULus - EAC - CCC	CE - cULus - EAC - CCC	CE - cULus - EAC - CCC
References			
Control Input:	0-20, 4-20, 12-20 mADC	0-20, 4-20, 12-20 mADC	0-20, 4-20, 12-20 mADC
1 Full Cycle, DC external supply	RGC2P60I25C1DM	RGC2P60I40C1DM	RGC2P60I75C1DFM
1 Full Cycle, AC external supply			RGC2P60I75C1AFM
4 Full Cycles, DC external supply	RGC2P60I25C4DM	RGC2P60I40C4DM	RGC2P60I75C4DFM
4 Full Cycles, AC external supply			RGC2P60I75C4AFM
Control Input:	0-10, 0-5, 1-5 VDC, Pot	0-10, 0-5, 1-5 VDC, Pot	0-10, 0-5, 1-5 VDC, Pot
1 Full Cycle, DC external supply	RGC2P60V25C1DM	RGC2P60V40C1DM	RGC2P60V75C1DFM
1 Full Cycle, AC external supply			RGC2P60V75C1AFM



Solid state contactors, 3-phase

4-20 mA Proportional controllers, 3 poles

Types	RGC3P60AA20.. 20 AAC	RGC3P60AA30.. 30 AAC
3-phase semiconductor proportional controllers with integrated heatsink, AC operating frequency range 45-65 Hz. Rated isolation voltage 4000 Vrms, 100 kArms short circuit current rating.		
Dimensions HxWxD (mm)	110 x 54 x 103	110 x 72 x 126
Features	54 mm solid state contactor with integrated varistors for over-voltage protection, screw with clamp for power connection	72 mm solid state contactor, integrated varistors for over-voltage protection, box clamp for power connection
Input specifications		
Control input	4-20 mADC	4-20 mADC
Voltage drop	<10 VDC @ 20 mADC	<10 VDC @ 20 mADC
Types		
Switching mode	Phase Angle [RGC..E] 1 Full Cycle [RGC..C1]	Phase Angle [RGC..E] 1 Full Cycle [RGC..C1]
Output specifications		
Rated operational current AC-51 @ Ta=40°C	20 AAC	30 AAC
Minimum operational current	500 mAAC	500 mAAC
Non. rep. surge current I _{sm} (t=10 ms)	600 A _p	1150 A _p
I ² t for fusing (t=10 ms)	1800 A ² s	6600 A ² s
Off-state leakage current	5 mAAC	5 mAAC
Critical dV/dt (@ T _j init=40°C)	1000 V/μs	1000 V/μs
General specifications		
Operational voltage range	180-600 VAC +10%	180-600 VAC +10%
Blocking voltage	1200 V _p	1200 V _p
Power factor	≥ 0.7 at rated voltage	≥ 0.7 at rated voltage
Operating temperature	-40°C to +70°C	-40°C to +70°C
Approvals/Marks	CE - cULus - EAC - CCC	CE - cULus - EAC - CCC
References		
Control Input:	4-20 mADC	4-20 mADC
Phase Angle	RGC3P60AA20E	RGC3P60AA30E
1 Full Cycle	RGC3P60AA20C1	RGC3P60AA30C1

Solid state contactors, 3-phase

Proportional controllers with monitoring, 3 poles

Types	RGC3P..20..EP RGC3P..20..M 20 AAC	RGC3P..30..EP RGC3P..30..M 30 AAC	RGC3P..65..EPF RGC3P..65..FM 66 AAC
Semiconductor contactors with integrated heatsink, AC operating frequency 45-65 Hz. Rated isolation voltage output to heatsink of 4000 Vrms, 100 kArms short circuit current rating.			
Dimensions HxWxD (mm)	110 x 54 x 118	110 x 72 x 141	141 x 72 x 141 (with fan)
Features	54 mm solid state contactor with integrated varistors for over-voltage protection, system monitoring, screw with clamp for power connection	72 mm solid state contactor with integrated varistors for over-voltage protection, system monitoring, box clamp for power connection	72 mm solid state contactor with fan and system monitoring, integrated varistors for over-voltage protection, box clamp for power connection

Input specifications

Control input	0-20, 4-20, 12-20 mADC [RGC..I..] 0-10, 0-5, 1-5 VDC [RGC..V..] External potentiometer [RGC..V..]	0-20, 4-20, 12-20 mADC [RGC..I..] 0-10, 0-5, 1-5 VDC [RGC..V..] External potentiometer [RGC..V..]	0-20, 4-20, 12-20 mADC [RGC..I..] 0-10, 0-5, 1-5 VDC [RGC..V..] External potentiometer [RGC..V..]
Input impedance	<250 Ω [RGC..I..] 100 kΩ [RGC..V..]	<250 Ω [RGC..I..] 100 kΩ [RGC..V..]	<250 Ω [RGC..I..] 100 kΩ [RGC..V..]
External supply voltage	24 VDC/AC [RGC..DM] 90-250 VAC [RGC..AM]	24 VDC/AC [RGC..DM] 90-250 VAC [RGC..AM]	24 VDC/AC [RGC..DFM] 90-250 VAC [RGC..AFM]
Max. supply current	90 mADC/AC [RGC..DM] 30 mAAC [RGC..AM]	90 mADC/AC [RGC..DM] 30 mAAC [RGC..AM]	175 mADC/AC [RGC..DFM] 60 mAAC [RGC..AFM]

Alarm specifications

Alarm output	EMR; 2 A 250 VAC / 30 VDC	EMR; 2 A 250 VAC / 30 VDC	EMR; 2 A 250 VAC / 30 VDC
Alarm condition	Mains loss, Load loss, SSR open cct., SSR short cct., SSR over temperature	Mains loss, Load loss, SSR open cct., SSR short cct., SSR over temperature	Mains loss, Load loss, SSR open cct., SSR short cct., SSR over temperature

Types

Switching mode	Phase Angle [RGC..E..] 1 Full Cycle [RGC..C1..] 4 Full Cycles [RGC..C4..] 16 Full Cycles [RGC..C16..] Softstart [RGC..S..]	Phase Angle [RGC..E..] 1 Full Cycle [RGC..C1..] 4 Full Cycles [RGC..C4..] 16 Full Cycles [RGC..C16..] Softstart [RGC..S..]	Phase Angle [RGC..E..] 1 Full Cycle [RGC..C1..] 4 Full Cycles [RGC..C4..] 16 Full Cycles [RGC..C16..] Softstart [RGC..S..]
----------------	--	--	--

Output specifications

Rated operational current AC-51 @ Ta=40°C	20 AAC	30 AAC	66 AAC
Minimum operational current	500 mAAC	500 mAAC	500 mAAC
Non. rep. surge current Ism (t=10ms)	600 Ap	1150 Ap	1750 Ap
I²t for fusing (t=10 ms)	1800 A²s	6600 A²s	15000 A²s
Off-state leakage current	5 mAAC	5 mAAC	5 mAAC
Critical dV/dt (@ Tj init=40°C)	1000 V/µs	1000 V/µs	1000 V/µs

General specifications

Operational voltage range	180-600 VAC +10%	180-600 VAC +10%	180-600 VAC +10%
Blocking voltage	1200 Vp	1200 Vp	1200 Vp
Power factor	≥ 0.7 at rated voltage	≥ 0.7 at rated voltage	≥ 0.7 at rated voltage
Operating temperature	-40°C to +70°C max. +60°C for 24 VAC supply	-40°C to +70°C max. +60°C for 24 VAC supply	-40°C to +70°C max. +60°C for 24 VAC supply
Approvals/Marks	CE - cULus - EAC - CCC	CE - cULus - EAC - CCC	CE - cULus - EAC - CCC





References

Phase Angle, DC external supply	RGC3P60Y20EDP	RGC3P60Y30EDP	RGC3P60Y65EDFP
Phase Angle, AC external supply		RGC3P60Y30EAP	RGC3P60Y65EAFP
X Full Cycle, DC external supply	RGC3P60Y20CXDM (X = 1/4/16)	RGC3P60Y30CXDM (X = 1/4/16)	RGC3P60Y65CXDFM (X = 1/4/16)
X Full Cycle, AC external supply		RGC3P60Y30CXAM (X = 1/4/16)	RGC3P60Y65CXAFM (X = 1/4/16)
Softstart + 16 Full Cycles, DC external supply	RGC3P60V20S16DM	RGC3P60V30S16DM	RGC3P60V65S16DFM
Digital Control Input (5-10 VDC):	5-10 VDC	5-10 VDC	5-10 VDC
Softstart + ON/OFF, DC external supply	RGC3P60V20SDM	RGC3P60V30SDM	RGC3P60V65SDFM

Y = 'I' for 0-20 mA, 4-20 mA or 12-20 mA or 'V' for 0-10 V, 0-5 V, 1-5 V or pot





CARLO GAVAZZI Automation Components. Specifications are subject to change without notice. Illustrations are for example only.

Solid state relays accessories

General accessories				
Types	RPM1	RPM1P	RPM1V	RPM2
				
Dimensions HxWxD (mm)	84 x 12.5 x 42	84 x 12.5 x 42	84 x 12.5 x 42	82 x 25 x 39
Description	DIN-rail adaptor for PCB relays. (Relay excluded)	DIN-rail adaptor with sockets for plug-in PCB relays. (Relay excluded)	DIN-rail adaptor for PCB relays with LED and varistor across output terminals. (Relay excluded)	DIN-rail adaptor for PCB relays with an operational voltage ≥ 230 V. (Relay excluded)
Pack quantity	1	1	1	2



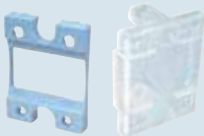

References	RPM1	RPM1P (no LED) RPM1PD (with LED)	RPM1V	RPM2
------------	------	-------------------------------------	-------	------

Selection guide for SSR assemblies*				
	RP...M1	RP...M1P (no LED) RP...M1PD (with LED)	RP...M1V	RP...M2

Types	DIN adaptor	DIN adaptor RG	Protection cover RM/RA/RK	Tamper proof cover RGS1P, RGC1P
				
Dimensions HxWxD (mm)	81 x 44 x 13.5	106 x 17.8 x 14	58 x 45 x 9 / 26	59 x 45 x 25.5
Description	DIN-rail adaptor for 1-phase SSR & heatsink assemblies. Integrated in heatsink kits	DIN-rail adaptor for RGS relays	Clip-on IP20 protection Cover	Tamper proof protection cover for RGS1P, RGC1P
Pack quantity	1	1	10 (RK)/20 [RMIP20]/25 [BBR..]	5

References	RHS00	RGS1DIN	RMIP20 (for RM, RS, RAM series) RKIP20 (for RK series) BBR (for RA series) BBR-S (for RA..S series)	RGTMP
------------	-------	---------	--	-------

Selection guide for SSR assemblies*				
	R...H8	RGS...DIN		





Types	Thermal paste	Thermal pad Slim SSRs	Thermal pad RM, RA	Thermal pad RZ3
				
Dimensions HxWxD (mm)		34.6 x 14 x 0.13 (RG) 21 x 19 x 0.13 (RF)	42 x 35 x 0.25	70 x 77 x 0.25
Description	2 ml syringe silicon based thermal compound	Thermal pad for RG and RF series	Graphite thermal pad for RA, RM, RAM, RS series	Graphite thermal pad for RZ3 series
Pack quantity	1	10	50	10





References	HTS02S	RGHT (for RG series) RFHT (for RF series)	KK071 CUT	RZHT
------------	--------	--	-----------	------





* Conditions may apply. Please ask your Sales representative for further details.

Solid state relays accessories





General accessories

Types	RM fork terminal	RM FASTON terminals	RM spacers	Overload relay adaptor
				
Dimensions HxWxD (mm)	35 x 16.5 x 25 / 29	4.8 / 6.3	M3 x 12	
Description	RM, RS, RK and RAM terminal adaptor for 16 mm ² and 35 mm ² cable	Screw FASTON terminals, flat or 45° angled for output (6.3 mm) and input (4.8 mm) RM, RS, RAM terminals	Standoff spacer for RM, RS, RAM series M3 control terminals	Overload Relay Adaptor for REC and RGCM3 series
Pack quantity	10	20	20	5
References	RM625FK (16 mm ²) RM635FK (35 mm ²) RM635FKP (35 mm ²)	RM48FO (4.8 mm, flat) RM48F4 (4.8 mm, 45°) RM63FO (6.3 mm, flat) RM63F4 (6.3 mm, 45°)	RMSP03	REC3ADAPTOR





Types	RG plug terminals	RGCM plug terminals	RK plug terminals	RG..M plug terminals
				
Description	2-pole spring loaded plug terminal, 2.5 mm ² for RG series	3 way, 2-pole box clamp plug terminal, 2.5 mm ² for RGCM3 series	4 way, 4-pole/2-pole spring loaded plug terminal, 5.08 mm for RK series	3-pole spring loaded plug terminal, 5.00 mm for RG..M series
Pack quantity	10	10	10	10
References	RGM25 RGMREF (for RG..N)	RG3G25	RK4MT (4 way, 4-pole) RK2MT (4 way, 2-pole)	RG3M15AL (labelled 'NC NO COM') RG3M15CTR (labelled 'A1+ A2- Us+')





Types	Cables	Termination resistor	Fans	Screw kits
				
Dimensions HxWxD (mm)			40 x 40 x 20 (RHSF40) 60 x 60 x 20 (RHSF60) 120 x 120 x 38 (RHS301F)	
Description	Cable for RM1E...V, RA2A...C, RK...C and RA...S models with one-end terminated with a female plug for mounting on the SSR	Termination resistor to be fitted on the last RG..N on the NRG bus chain	RHSF40-24 to be mounted with RHS45C, RHS45B, RHS540, RHS542 RHSF60-24/240 to be mounted with RHS90A, RHS112A, RHS703 RHS301F115/230 to be mounted with RHS301 incl. bracket	Screw kits for assembling SSRs to heatsinks. M5 x 10 mm to be used with RA, RM, RAM, RS, RK and RZ3 series. M4 x 15 mm used for RHS38AD heatsink. M5 x 23 / 30 mm to be used with RG series
Pack quantity	1		1	20
References	RCS3-100-1 [RM1E..V] RCS4-100-1 [RA2A..C] RCS4-400-1 [RA2A..C] RCS5-200-1 [RA..S] RCK4-100-1 [RK2..C] RCK2-100-1 [RK2..C]	RGN-TERMRES	RHSF40-24 (24 VDC) RHSF60-24 (24 VDC) RHSF60-230 (240 VAC) RHS301F115 (115 VAC) RHS301F230 (230 VAC)	SRWKITM5X10MM SRWKITM4X15MM SRWKITM5X23MM SRWKITM5X30MM

Solid state relays accessories

	General accessories		DIN mount heatsinks for solid state relays	
Types	Varistors	Temperature limit switches	RHS300	RHS37A
				
Dimensions HxWxD (mm) (SSR not included)		6.5 x 5.5 x 3	105 x 82 x 20	18 x 110 x 52
Description	Surge / transient voltage protection for SSRs	Temperature limit switches that may be fitted in the RZ3 housing between SSR and heatsink	Heatsink for 1x 3-phase RZ3 series	Heatsink for 1x 1-phase RG series
Pack quantity	10	1		

Thermal resistance**				
Without fan	-	-	5.40°C/W (>30 W)	4.00°C/W (>20 W)
References / Selection guide for heatsink assemblies*				
	275 V: RV02	420 V: RV04	UP62-70	
	510 V: RV05	625 V: RV06	UP62-80	
	680 V: RV07	UP62-90		
Without fan			R...H1	R...H51

DIN mount heatsinks for solid state relays				
Types	RHS10015	RHS100	RHS45C	RHS52A
				
Dimensions HxWxD (mm) (SSR not included)	100 x 82 x 29	44 x 82 x 48	45 x 103 x 55	22.5 x 110 x 90
Description	Heatsink for max. 2x 1-phase RA, RM, RAM, RS and RK series	Heatsink for 1x 1-phase RA, RM, RAM, RS and RK series	Heatsink for 1x 1-phase RA, RM, RAM, RS and RK series	Heatsink for 1x 1-phase RG series
Thermal resistance**				
Without fan	4.00°C/W (>30 W)	3.10°C/W (>25 W)	2.20°C/W (>45 W)	2.00°C/W (>45 W)
Selection guide for heatsink assemblies*				
Without fan	R...H47	R...H0	R...H15	R...H61

Types	RHS45B	RHS54..	RHS703..	RHS90A
				
Dimensions HxWxD (mm) (SSR not included)	45 x 103 x 80	54 x 110 x 51	72 x 110 x 75	90 x 103 x 80
Description	Heatsink for 1x 1-phase RA, RM, RAM, RS and RK series	Heatsink for max. 3x 1-phase RG series, 1x 1-phase RA, RM, RAM, RS and RK series: RHS540 Heatsink for max. 2x 1-phase RG series: RHS542	Heatsink for max. 3x 1-phase RG series, 1x 1-phase RA, RM, RAM, RS and RK series	Heatsink for 1x 1-phase RA, RM, RAM, RS and RK series
Thermal resistance**				
Without fan	1.85°C/W (>50 W)	1.85°C/W (>60 W)	1.10°C/W (>60 W)	0.97°C/W (>60 W)
Selection guide for heatsink assemblies*				
Without fan	R...H5	R...H65 [RHS540] R...H66 [RHS542]	R...H75 [RHS703]	R...H16







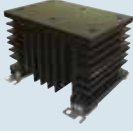

* Conditions may apply. Please ask your Sales representative for further details.

** Refer to specific heatsink datasheet for further details on heatsink characteristics and assemblies.

CARLO GAVAZZI Automation Components. Specifications are subject to change without notice. Illustrations are for example only.

Solid state relays accessories

DIN mount heatsinks for solid state relays



Types	RHS301..	RHS112A..	RHS11267DIND
			
Dimensions HxWxD (mm) (SSR not included)	119 x 82 x 94	112 x 103 x 80	119 x 125 x 94
Description	Heatsink for 1x 3-phase RZ3, 2x 1-phase RA, RM, RAM, RS and RK series: RHS301	Heatsink for 1x 3-phase RZ3, 2x 1-phase RA, RM, RAM, RS and RK series: RHS112A	Heatsink for 1x 3-phase RZ3 series, max 3x 1-phase RG series, 2x 1-phase RA, RM, RAM, RS and RK series
Thermal resistance**			
Without fan	0.82°C/W (> 80 W)	0.76°C/W (>100 W)	0.54°C/W (>150 W)
Selection guide for heatsink assemblies*			
Without fan	R...H2 [RHS301]	R...H17	R...H78D
Types	RHS54..F	RHS703..F	RHS301..F
			
Dimensions HxWxD (mm) (SSR not included)	54 x 135 x 51	72 x 141 x 75	124 x 146 x 122
Description	Heatsink for max. 3x 1-phase RG series, 1x 1-phase RA, RM, RAM, RS and RK series: RHS540F40-24 (24 VDC fan) Heatsink for max. 2x 1-phase RG series: RHS542F40-24 (24 VDC fan)	Heatsink for max. 3x 1-phase RG series, 1x 1-phase RA, RM, RAM, RS and RK series: RHS703F60-24 (24 VDC fan) RHS703F60-230 (240 VAC fan)	Heatsink for 1x 3-phase RZ3, 2x 1-phase RA, RM, RAM, RS and RK series: RHS301F115C [115 VAC fan] RHS301F230C [230 VAC fan]
Thermal resistance**			
With fan	0.65°C/W	0.37°C/W	0.28°C/W
Selection guide for heatsink assemblies*			
With fan	R...H67 [RHS540F40-24] R...H68 [RHS542F40-24]	R...H76 [RHS703F60-24] R...H77 [RHS703F60-230]	R...H10 [RHS301F115C] R...H12 [RHS301F230C]
Types	RHS112A..F	RHS28009F80-24P	RHS28011F80-24P
			
Dimensions HxWxD (mm) (SSR not included)	112 x 103 x 80 112 x 120 x 80 (with fan)	280 x 87 x 122	280 x 87 x 122
Description	Heatsink for 1x 3-phase RZ3, 2x 1-phase RA, RM, RAM, RS and RK series: RHS112AF60-24 [24 VDC fan] RHS112AF60-230 [230 VAC fan]	Heatsink for max. 9x 1-phase RG series or 4x 1-phase RA, RM, RAM, RS and RK series with integrated fan and overtemperature protection	Heatsink for max. 11x 1-phase RG series or 3x 1-phase RA, RM, RAM, RS and RK series with integrated fan and overtemperature protection
Thermal resistance**			
With fan	0.35°C/W	0.12°C/W (24 VDC)	0.12°C/W (24 VDC)
Selection guide for heatsink assemblies*			
With fan	R...H18 [RHS112AF60-24] R...H52 [RHS112AF60-230]	R...H41	R...H44

* Conditions may apply. Please ask your Sales representative for further details.

** Refer to specific heatsink datasheet for further details on heatsink characteristics and assemblies.

Solid state relays accessories

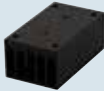
Thru wall mount heatsinks for solid state relays

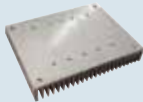
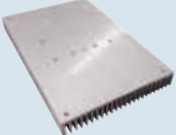



Types	RHS38ARFD	RHS10025D	RHS16225D	RHS16225LD
				
Dimensions HxWxD (mm) (SSR not included)	46 x 76 x 33	100 x 100 x 25	162 x 100 x 25	162 x 250 x 25
Description	Heatsink for 1x 1-phase RF series	Heatsink for max. 3x 1-phase RG series, 1x 1-phase RA, RM, RAM, RS and RK series	Heatsink for 1x 3-phase RZ3 series, max. 3x 1-phase RA, RM, RAM, RS, RK and RG series	Heatsink for 1x 3-phase RZ3 series, max. 3x 1-phase RA, RM, RAM, RS, RK and RG series
Thermal resistance**				
Without fan	2.85°C/W (>40 W)	1.85°C/W (>60 W)	1.30°C/W (>90 W)	0.84°C/W (>120 W)
References / Selection guide for heatsink assemblies*				
Without fan	R...H53	R...H49	R...H55	R...H55L

Thru wall mount heatsinks for solid state relays

Panel mount heatsinks for solid state relays

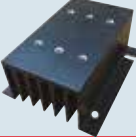
Types	RHS11267D	RHS30040D	RHS5050..	RHS38A..
				
Dimensions HxWxD (mm) (SSR not included)	112 x 125 x 67	300 x 200 x 40	80 x 50 x 51	46 x 76 x 33
Description	Heatsink for max. 3x 1-phase RG series or 1x 1-phase RA, RM, RAM, RS and RK series	Heatsink for max. 12x 1-phase RG series or 8x 1-phase RA, RM, RAM, RS and RK series	RHS5050D: Heatsink for 1x 1-phase RA, RM, RAM, RS and RK series RHS5050RFD: Heatsink for 1x 1-phase RF series	RHS38AD: Heatsink for 1x 1-phase RA, RM, RAM, RS and RK series RHS38ARFD: Heatsink for 1x 1-phase RF series
Thermal resistance**				
Without fan	0.54°C/W (>150 W)	0.40°C/W (>180 W)	3.50°C/W (>25 W)	2.85°C/W (>40 W)
Selection guide for heatsink assemblies*				
Without fan	R...H78	R...H57	R...H60	R...H53

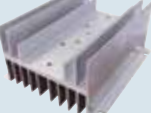
Panel mount heatsinks for solid state relays

Types	RHS5840D	RHS10067D	RHS10067LD	RHS320
				
Dimensions HxWxD (mm) (SSR not included)	81 x 100 x 40	121 x 76 x 67	121 x 140 x 67	240 x 100 x 93
Description	Heatsink for max. 3x 1-phase RG series, 1x 1-phase RA, RM, RAM, RS and RK series	Heatsink for 1x 1-phase RA, RM, RAM, RS and RK series	Heatsink for 2x 1-phase RA, RM, RAM, RS, RK and RG series	Heatsink for 1x 3-phase RZ3 series, max. 3x 1-phase RA, RM, RAM, RS, RK and RG series
Thermal resistance**				
Without fan	1.80°C/W (>60 W)	1.70°C/W (>20 W)	0.88°C/W (>80 W)	0.40°C/W (>120 W)
Selection guide for heatsink assemblies*				
Without fan	R...H48	R...H58	R...H58L	R...H13

* Conditions may apply. Please ask your Sales representative for further details.

** Refer to specific heatsink datasheet for further details on heatsink characteristics and assemblies.

Soft starters

Scroll compressor soft starters

Types

RSBS

RSBD 45 & 75 mm

RSBT 45 & 120 mm

Soft starting of 1-phase (RSBS) and 3-phase (RSBD, RSBT) scroll compressors.



Dimensions (mm)

70.6 x 137 x 81.4

12 A to 45 A:
106 x 45 x 125
55 A to 95 A:
150 x 75 x 170

16 A to 32 A (no relay output):
81 x 45 x 125
16 A to 32 A (with relay output):
97.5 x 45 x 125
55 A to 95 A: 150 x 120 x 170

Features

Internally bypassed, current limit start, auxiliary relay output, HP algorithm for high pressure starts, Option for external start capacitor

Compact 2-phase (RSBD) controlled soft starter for scroll compressors. Patented auto-adapt function for reduction of inrush current and for current balancing. No user settings required. HP algorithm optimised for multi-compressor systems

3-phase (RSBT) controlled solution with internal bypass. Patented self-learning algorithm for optimal current reduction. Compliant to Class B (residential limits) for EMC emissions (16 A to 32 A). Optional serial communication for energy variables, alarms, start/stop

Control specifications

Control input range

230 VAC

Option E: 110 - 400 VAC
Option F: 24 VAC/DC

Option E: 110 - 400 VAC [RSBT 45 mm]
Option C: 24 VAC/DC
& 110-400 VAC [RSBT 120 mm]

Controlled phases

1

2

3

Output specifications

Rated operational current (Ie)

32 A

RSBD 45 mm: 12/16/25/32/37/45 A
RSBD 75 mm: 55/70/95 A

RSBT 45 mm: 16/25/32 A
RSBT 120 mm: 55/70/95 A

Operational voltage

230 VAC (-15%, +10%)

RSBD 45 mm: 220 - 400 VAC (-15%, +10%)
RSBD 75 mm: 220 - 600 VAC (-15%, +10%)

RSBT 45 mm: 220/400 VAC (-15%, +10%)
RSBT 120 mm: 220 - 480 VAC (-15%, +10%)

Number of starts per hour

10 (evenly distributed)

12 (evenly distributed)

12 (evenly distributed)

Assigned compressor rating @ 400 V

4 kW (5 HP) [@ 230 V]

RSBD 45 mm:
5.5 kW (5 HP) to 22 kW (25 HP)
RSBD 75 mm:
30 kW (30 HP) to 55 kW (50 HP)

RSBT 45 mm:
7.5 kW (7.5 HP) to 15 kW (15 HP)
RSBT 120 mm:
22 kW (30 HP) to 45 kW (50 HP)

General specifications

Internally bypassed

Yes

Yes

Yes

Operational frequency

50/60 Hz ±10%

50/60 Hz ±10 Hz

50/60 Hz ±10 Hz

Ramp up/Ramp down

< 1 s / 0 s

< 1 s / 0 s

< 1 s / 0 s

Default Current limit

45 Arms
(80 Arms in HP mode)

3.5xIe

RSBT 45 mm RSBT..16: 40 A,
RSBT..25: 90 A,
RSBT..32: 110 A
RSBT 120 mm: 3.5xIe

Operating temperature

RSBS...CO0HP: -20°C to +65°C (-4°F to +149°F)
RSBS...CxxHP: -20°C to +55°C (-4°F to +131°F)

-20°C to +60°C (-4°F to +140°F)

-20°C to +60°C (-4°F to +140°F)

Storage temperature

-30°C to +70°C (-22°F to +158°F)

-40°C to +80°C (-40°F to +176°F)

-40°C to +85°C (-40°F to +185°F)

Wrong phase sequence indication

N/A

Yes

Yes

Degree of protection

IP20

RSBD 45 mm: IP20
RSBD 75 mm: IP20 (Housing) /
IP10 (Terminals)

RSBT 45 mm: IP20
RSBT 120 mm: IP20 (Housing) /
IP10 (Terminals)

Approvals

CE-UL - cULus - EAC

RSBD 45 mm: CE - cULus - EAC
RSBD 75 mm: CE - cULus - EAC

RSBT 45 mm: CE - cULus* - VDE** - CCC
RSBT 120 mm: CE - cULus - CCC - EAC

* For options V50/ V51/ V61
** Up to 15 AAC (Up to 32 AAC for RSBT..HPV models only)
xx = 10, 17, 24

Soft starters

Centrifugal pump and ventilators soft starters

Types

RSWT 45 mm

RSWT 75 & 120 mm

Soft-starters with dedicated, self-learning algorithm for centrifugal pumps and ventilators.



Dimensions (mm)

RSWT4012/RSWT4016: 130 x 45 x 125
RSWT4025: 157 x 45 x 125

RSWT 75 mm: 177 x 75 x 206
RSWT 120 mm: 177 x 120 x 206

Features

3-phase controlled, internally bypassed. Self-learning algorithm dedicated to centrifugal pumps and ventilators. Integrated overload protection (Class 10). RSWT40 versions - internally supplied

3-phase controlled and internally bypassed. Integrated overload protection, PTC i/p, remote alarm reset. RSWT40 versions - internally supplied. 3 output relays for alarm, top of ramp and run indication

Control specifications

Control input range

Option E: 110 - 400 VAC [RSWT40...]
Option F: 24 VAC/DC [RSWT40...]
Option GG: 100 - 240 VAC [RSWT60..]
Option FF: 24 VAC/DC [RSWT60..]

Option E: 110 - 400 VAC [RSWT40...]
Option F: 24 VAC/DC [RSWT40...]
Option GG: 100 - 240 VAC [RSWT60..]
Option FF: 24 VAC/DC [RSWT60..]

Controlled phases

3

3

Output specifications

Rated operational current AC 53b

12/16/25 A

32/37/45/55/70/90 A

Operational voltage

RSWT40: 220 - 400 VAC (-15%, +10%)
RSWT60: 220 - 600 VAC (-15%, +10%)

RSWT40: 220 - 400 VAC (-15%, +10%)
RSWT60: 220 - 600 VAC (-15%, +10%)

Number of starts per hour @ 40°C

20

20

Assigned motor rating @ 400 V

RSWTxx12: 5.5 kW (5 HP)
RSWTxx16: 7.5 kW (7.5 HP)
RSWTxx25: 11 kW (10 HP)

RSWTxx32: 15 kW (20 HP)
RSWTxx37: 18.5 kW (25 HP)
RSWTxx45: 22 kW (30 HP)
RSWTxx55: 25 kW (35 HP)
RSWTxx70: 37 kW (40 HP)
RSWTxx90: 45 kW (50 HP)

General specifications

Internally bypassed

Yes

Yes

Operational frequency

50/60 Hz ±10%

50/60 Hz ±10%

Ramp up/Ramp down

1-20 s / 0-20 s

1-20 s / 0-20 s

Initial torque

Self-adjusted by RSWT

Self-adjusted by RSWT

Operating temperature

-20°C to 60°C (-4°F to +140°F)

-20°C to 60°C (-4°F to +140°F)

Storage temperature

-40°C to +80°C (-40°F to +176°F)

-40°C to +80°C (-40°F to +176°F)

Integrated overload protection

Yes

Yes

Degree of protection

IP20

IP20 (control circuit)
IP10 (power terminals)

Approvals

CE - cULus - CCC - EAC

CE - cULus - CCC - EAC

Soft starters

General purpose soft starters

Types

RSGD 45 mm

RSGD 75 mm

Soft starting and stopping of 3-phase motors. Self-learning algorithm on RSGD series for better ease of use.



Dimensions (mm)

106 x 45 x 125 [RSGD..VD2.0]
137 x 45 x 137 [RSGD..VX2.0]

177 x 75 x 206 [RSGD..55.. - RSGD..85..]
177 x 75 x 221 [RSGD..100..]

Features

Self-learning 2-phase controlled general purpose soft starter. Improved current reduction capability. 2-relay outputs for top of ramp and alarm indication. Optional motor overload protection (Class 10). QR code for quicker troubleshooting

Self-learning 2-phase controlled general purpose soft starter. Integrated motor overload protection (Class 10) and serial communication (Modbus RS485)

Control specifications

Control input range

Option E0: 110 - 400 VAC [RSGD40..]
Option F0: 24 VAC/DC [RSGD40..]
Option GG: 100 - 240 VAC [RSGD60..]

Option E0: 110 - 400 VAC [RSGD40..]
Option F0: 24 VAC/DC [RSGD40..]
Option FF: 24 VAC/DC [RSGD60..]
Option GG: 100 - 240 VAC [RSGD60..]

Controlled phases

2

2

Output specifications

Rated operational current AC 53b

12/16/25/32/45 A

55/70/85/100 A

Operational voltage

RSGD40: 220 - 400 VAC (-15%, +10%)
RSGD60: 220 - 600 VAC (-15%, +10%)

RSGD40: 220 - 400 VAC (-15%, +10%)
RSGD60: 220 - 600 VAC (-15%, +10%)

Number of starts per hour @ 40°C

20 - [RSGD..12, RSGD..16, RSGD..25, VX210, RSGD..32]
10 - [RSGD..25..VD200, RSGD..45]

10

Assigned motor rating @ 400 V

RSGD..12: 5.5 kW/5 HP
RSGD..16: 7.5 kW/7.5 HP
RSGD..25: 11 kW/10 HP
RSGD..32: 15 kW/15 HP
RSGD..45: 22 kW/25 HP

RSGD..55: 30 kW/30 HP
RSGD..70: 37 kW/40 HP
RSGD..85: 45 kW/50 HP
RSGD..100: 55 kW/50 HP

General specifications

Internally bypassed

Yes

Yes

Operational frequency

50/60 Hz ±10%

50/60 Hz ±10%

Ramp up/Ramp down

1 - 20 s / 0 - 20 s

1 - 30 s / 0 - 30 s

Initial torque

Not required

Not required

Operating temperature

-20°C to 60°C (-4°F to +140°F)

-20°C to 60°C (-4°F to +140°F)

Storage temperature

-40°C to +80°C (-40°F to +176°F)

-40°C to +80°C (-40°F to +176°F)

Wrong phase sequence indication

Yes

Yes

Motor overload protection

V.200: No
V.210: Yes (Class 10)

Yes (Class 10)

PTC input

No

Yes

Degree of protection

IP20

IP20 (control circuit)
IP10 (power terminals)



Approvals

CE - cULus - CCC - EAC

CE - cULus - CCC - EAC

Soft starters

Solid state soft starters and motor reversing

Types	RGTS 1-phase	RR2A Reversing
Single phase solid state soft starter and three phase motor reversing with built-in interlock.		
Dimensions (mm)	113 x 54 x 110	41 x 103 x 74
Features	Single phase solid state soft starter. Wide operational voltage range. 100 kArms short circuit current rating	Reversing with built-in interlock, optoisolation 2-pole change-over, built-in transient overvoltage protection, LED status indication
Control specifications		
Control input range	No control signal required (starts as soon as mains voltage is present)	10 - 40 VDC [RR2A..D...] 90 - 140 VAC [RR2A..LA...] 180 - 265 VAC [RR2A..HA...]
Controlled phases	1	2
Output specifications		
Rated operational current AC 53a	12 A [RGTS2412...] 16 A [RGTS2416...] 25 A [RGTS2425...]	5 A [RR2A40D150/RR2A48D220] 11 A [RR2A40D400/RR2A48D550]
Operational voltage	100 - 240 VAC	40 - 440 VAC [RR2A40D...] 40 - 530 VAC [RR2A48D...]
Number of starts per hour @ 40°C	10	60 - [RR2A..150/RR2A..220] 40 - [RR2A..400/RR2A..550]
Assigned motor rating @ 400 V (for RR2A only)	RGTS2412...: 1.1 kW / 2 HP	RR2A..150: 1.5kW / 2 HP
Assigned motor rating @ 230 V (for RGTS only)	RGTS2416...: 1.5 kW / 2 HP	RR2A..220: 2.2kW / 3 HP
	RGTS2425...: 3.0 kW / 3 HP	RR2A..400: 4.0 kW / 5 HP
		RR2A..550: 5.5 kW / 7.5 HP
General specifications		
Internally bypassed	No	No
Operational frequency	50/60 Hz ±10%	50/60 Hz ±10%
Ramp up/Ramp down	0.5 - 5 s/0 s	No ramp-up/ramp-down
Initial torque	10 - 80 %	Not applicable
Operating temperature	-40°C to +60°C (-40°F to +140°F)	-20°C to +80°C (-4°F to +176°F)
Storage temperature	-40°C to +100°C (-40°F to +212°F)	-40°C to +100°C (-40°F to +212°F)
Wrong phase sequence indication	No	No
Motor overload protection	No	No
PTC input	No	No
Degree of protection	IP20	IP20
Approvals	CE - cULus	CE - UL - cUL

Soft starters

Dynamic motor starter

Types

HDMS

Single phase motor starter for scroll compressors and submersible pumps



Dimensions (mm)

153 x 85.6 x 86.7

Features

Eliminates the start capacitor
Self-learning algorithm
Tool-free terminals
NFC & Modbus interface
Coated PCBs

Control specifications

Control input range

110 - 230 VAC

Controlled phases

1

Output specifications

Rated operational current AC 53b

12, 25, 32, 37 AAC

Operational voltage

110 - 230 VAC

Number of starts per hour @ 40°C

10

Assigned motor rating @ 110 VAC

HDMS2312...: 0.56 kW / 0.75 HP
HDMS2325...: 1.1 kW / 2 HP
HDMS2332...: 1.5 kW / 2 HP
HDMS2337...: 2.2 kW / 3 HP

Assigned motor rating @ 230 VAC

HDMS2312...: 1.5 kW / 2 HP
HDMS2325...: 3.7 kW / 5 HP
HDMS2332...: 4 kW / 5.5 HP
HDMS2337...: 5.5 kW / 7.5 HP

General specifications

Internally bypassed

Yes

Operational frequency

50/60 Hz ±10%

Ramp up/Ramp down

< 1 s / 0 s

Initial torque

Automatically adjusted

Operating temperature

-20°C to +65°C (-4°F to +149°F)

Storage temperature

-40°C to +80°C (-40°F to +176°F)

Wrong phase sequence indication

No

Motor overload protection

Yes

Communication interface

NFC, Modbus RTU

Degree of protection





IP 00

Approvals

CE - cULus

Variable frequency drives

VariFlex³ variable frequency drives - RVLf series

Types	Size A	Size B	Size C	Size D
Drives, Inverters				
Dimensions HxWxD (mm)	141 x 72 x 139	144 x 118 x 147	197 x 129 x 148	273 x 187 x 190
Features	V/F and Sensorless vector control algorithm Conform to EMC standard EN 61800-3 In-built PTC and PID functions In-built RJ45 for Modbus and BACnet communication Additional communication protocol via add-on modules			

Technical specifications

AC Supply voltage	1-ph: 100 - 120 VAC 1-ph: 200 - 240 VAC 3-ph: 200 - 240 VAC	1-ph: 200 - 240 VAC 3-ph: 200 - 240 VAC 3-ph: 380 - 480 VAC	3-ph: 380 - 480 VAC	3-ph: 380 - 480 VAC
AC Supply frequency	50 - 60 Hz	50 - 60 Hz	50 - 60 Hz	50 - 60 Hz
Output voltage	3-ph: 0 - 240 VAC [RVLFA1../RVLFA320...]	3-ph: 0 - 240 VAC [RVLFB1../RVLFB320...] 3-ph: 0 - 480 VAC [RVLFB340...]	3-ph: 0 - 480 VAC [RVLFC340...]	3-ph: 0 - 480 VAC [RVLFD340...]
Output frequency	0.01 - 599 Hz	0.01 - 599 Hz	0.01 - 599 Hz	0.01 - 599 Hz
Rated output current	2.6 A [RVLFA..040...] 4.3 A [RVLFA..075...] 7.5 A [RVLFA..150...]	7.5 A [RVLFB..150...] 10.5 A [RVLFB..220...] 2.3 A [RVLFB34..075...] 3.8 A [RVLFB34..150...] 5.2 A [RVLFB34..220...]	9.2 A [RVLFB34..370...] 13.0 A [RVLFB34..550...]	17.5 A [RVLFB34..750...] 24.0 A [RVLFB34..1100...]
Allowable momentary power loss		2.0 s	2.0 s	2.0 s

General specifications





Operating temperature	-10°C to +50°C	-10°C to +50°C	-10°C to +50°C	-10°C to +50°C
Storage temperature	-20°C to +60°C	-20°C to +60°C	-20°C to +60°C	-20°C to +60°C
Digital inputs	5	5	5	5
Digital outputs	1 (Programmable)	1 (Programmable)	1 (Programmable)	1 (Programmable)
Analogue inputs	2 (0 - 10 VDC, 0 - 20 mA)	2 (0 - 10 VDC, 0 - 20 mA)	2 (0 - 10 VDC, 0 - 20 mA)	2 (0 - 10 VDC, 0 - 20 mA)
Analogue outputs	1 (0 - 10 VDC)	1 (0 - 10 VDC)	1 (0 - 10 VDC)	1 (0 - 10 VDC)
Mounting	Panel mount DIN-rail (with accessory)	Panel mount DIN-rail (with accessory)	Panel mount	Panel mount
Integrated cooling fan	No	Yes	Yes	Yes
Switching frequency	1 to 16 kHz	1 to 16 kHz	1 to 16 kHz	1 to 16 kHz
Approvals	CE - cULus	CE - cULus	CE - cULus	CE - cULus

References

100 - 120 VAC, 1-phase	RVLFA110040A [0.4kW] RVLFA110075A [0.75kW]			
200 - 240 VAC, 1-phase	RVLFA120040FA [0.4kW] RVLFA120075FA [0.75kW]	RVLFB120150FA [1.5kW] RVLFB120220FA [2.2kW]		
200 - 240 VAC, 3-phase	RVLFA320040A [0.4kW] RVLFA320075A [0.75kW]	RVLFB320150A [1.5kW] RVLFB320220A [2.2kW]		
380 - 480 VAC, 3-phase		RVLFB340075FA [0.75kW] RVLFB340150FA [1.5kW] RVLFB340220FA [2.2kW]	RVLFC340370FA [3.7kW] RVLFC340550FA [5.5kW]	RVLFC340750FA [7.5kW] RVLFC3401100FA [11kW]

Variable frequency drives

Accessories

Types	DNET Module	Profibus Module	CAN Module	TCP-IP Module
				
Dimensions HxWxD (mm)	106 x 38 x 59.3	106 x 38 x 59.3	106 x 38 x 59.3	106 x 38 x 59.3
Features	DeviceNET communication module	Profibus communication module	CANopen communication module	TCP-IP communication module
Technical specifications				
Supply voltage	24 VDC, 50 mA	24 VDC, 50 mA	24 VDC, 50 mA	24 VDC, 50 mA
General specifications				
Operating temperature	-10°C to +50°C	-10°C to +50°C	-10°C to +50°C	-10°C to +50°C
Storage temperature	-20°C to +70°C	-20°C to +70°C	-20°C to +70°C	-20°C to +70°C
Degree of protection	IP20	IP20	IP20	IP20
Connections	Screw terminals	Screw terminals	Screw terminals	Screw terminals
Mounting	DIN-rail or panel mounting	DIN-rail or panel mounting	DIN-rail or panel mounting	DIN-rail or panel mounting

References



RV-DNET

RV-PDP

RV-CAN

RV-TCP/IP

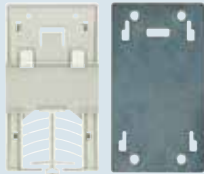
Accessories

Types	DIN-clip RVLf size A	DIN-clip RVLf size B	USB connection cable
			
Features	Plastic DIN-clip and mounting screws for RVLf Size A models	Plastic DIN-clip and mounting screws for RVLf Size B models	Isolated USB to RJ45 cable for RVLf configuration





References

RVLf-DIN01

RVLf-DIN02

RV-USB

Industrial and Midi industrial relays

	Industrial relays		Midi industrial relays	
Types	RCP 8 (2 Poles)	RCP 11 (3 Poles)	RMI 2-10 (2 Poles)	RMI 4-5 (4 Poles)
				
Dimensions HxWxD (mm)	56 x 35.5 x 35.5	56 x 35.5 x 35.5	37 x 21.5 x 28	37 x 21.5 x 28
No. of Contacts	2 Change-over (octal)	3 Change-over (undecal)	2 Change-over	4 Change-over
Contact rating	10 A	10 A	10 A	6 A
Features	Test button / Flag / LED	Test button / Flag / LED	Test button / Flag / LED	Test button / Flag / LED

Output specifications

Max. load AC1	12 A / 250 VAC	12 A / 250 VAC	12 A / 250 VAC	6 A / 250 VAC
Min. load	100 mA / 12 VDC	100 mA / 125 VDC	100 mA / 5 VDC	100 mA / 5 VDC
Electrical life	> 100.000 cycles	> 100.000 cycles	> 100.000 cycles	> 100.000 cycles
Switching power	2500 VA (resistive)	2500 VA (resistive)	2500 VA (resistive)	1250 VA (resistive)

General specifications

Voltage ranges VDC	6 - 12 - 24 - 48 - 60 - 110	6 - 12 - 24 - 48 - 60 - 110	12 - 24 - 48 - 60 - 110	12 - 24 - 48 - 60 - 110
Voltage ranges VAC	6 - 12 - 24 - 48 - 115/120 - 230	6 - 12 - 24 - 48 - 115/120 - 230	12 - 24 - 48 - 115/120 - 230	12 - 24 - 48 - 115/120 - 230
Insulation according to	EN 61810-1	EN 61810-1	EN 61810-1	EN 61810-1
Consumption	1.5 W DC-2.5 VA AC	1.5 W DC-2.5 VA AC	1 W DC-1.4 VA AC	1 W DC-1.4 VA AC
Approvals / Conformity	CE - cURus - CSA - IMQ - RINA	CE - cURus - CSA - IMQ - RINA	CE - cURus - CSA - IMQ - RINA	CE - cURus - CSA - IMQ - RINA

References

6 VDC	RCP80026 VDC	RCP110036 VDC		
12 VDC	RCP800212 VDC	RCP1100312 VDC	RMIA21012 VDC	RMIA4512 VDC
24 VDC	RCP800224 VDC	RCP1100324 VDC	RMIA21024 VDC	RMIA4524 VDC
48 VDC	RCP800248 VDC	RCP1100348 VDC	RMIA21048 VDC	RMIA4548 VDC
60 VDC	RCP800260 VDC	RCP1100360 VDC	RMIA21060 VDC	RMIA4560 VDC
100 VDC	RCP8002100 VDC	RCP11003100 VDC		
11 0VDC	RCP8002110 VDC	RCP11003110 VDC	RMIA210110 VDC	RMIA45110 VDC
6 VAC	RCP80026 VAC	RCP110036 VAC		
12 VAC	RCP800212 VAC	RCP1100312 VAC	RMIA21012 VAC	RMIA4512 VAC
24 VAC	RCP800224 VAC	RCP1100324 VAC	RMIA21024 VAC	RMIA4524 VAC
48 VAC	RCP800248 VAC	RCP1100348 VAC	RMIA21048 VAC	RMIA4548 VAC
115/120 VAC	RCP8002115/120 VAC	RCP11003115/120 VAC	RMIA210115/120 VAC	RMIA45115/120 VAC
230 VAC	RCP8002230 VAC	RCP11003230 VAC	RMIA210230 VAC	RMIA45230 VAC
Options	Consult your Carlo Gavazzi partner or distributor			

	Industrial relays sockets		Midi industrial relays sockets	
Types	ZPD 8XA ZPD 11XA	ZPD 8A ZPD 11A	ZMI 2NA ZMI 4NA	ZMI 2 / 3 / 4SA
				

General specifications

Dimensions HxWxD (mm)	65 x 27 x 38	65 x 27 x 38	42.5 x 75 x 27	42.5 x 75 x 27
Rated volt. / Rated curr.	10 A @ 400 VAC	10 A @ 400 VAC	10 A @ 300 VAC	10/12 A @ 300 VAC
Insulation voltage	> 3 kV	> 3 kV	> 4 kV	> 4 kV
Socket material	Self-ext. PA6 + GF (V1)	Self-ext. PA6 + GF (V1)	Self-ext. PA6 + GF (V2)	Self-ext. PA6 + GF (V2)
Mounting	DIN-rail	DIN-rail	DIN-rail	DIN-rail
Degree of protection	IP20	IP20	IP20	IP20
Approvals	CE - cURus - CSA (10 A 300 VAC)	CE - cURus - CSA - IMQ	CE - cURus - CSA	CE - cURus - CSA

References

For RCP 8 / RCP 11	ZPD 8XA / ZPD 11XA	ZPD 8A / ZPD 11A		
For RMI2-10 / RMI4-5			ZMI 2NA / ZMI 4NA	ZMI 2 / 3 / 4SA

Midi industrial relays

Midi industrial relays

Types	RPY 1	RPY 2	RPY 3	RPY 4
				

Dimensions HxWxD (mm)	36 x 21.5 x 28	36 x 21.5 x 28	36 x 31.5 x 28	36 x 41.5 x 28
No. of Contacts	1 Change-over	2 Change-over	3 Change-over	4 Change-over
Contact rating	16 A	10 A	10 A	10 A
Terminal types	Faston or PCB	Faston or PCB	Faston or PCB	Faston or PCB

Output specifications

Max. load AC1	16 A	10 A	10 A	10 A
Electrical life	1 x 10 ⁵	1 x 10 ⁵	1 x 10 ⁵	1 x 10 ⁵
Switching power	1 HP at 240 VAC 1/2 HP at 120 VAC	3/4 HP at 240 VAC 1/3 HP at 120 VAC	3/4 HP at 240 VAC 1/3 HP at 120 VAC	3/4 HP at 240 VAC 1/3 HP at 120 VAC



General specifications

Voltage ranges VDC	6 - 12 - 24 - 36 - 48 - 110	6 - 12 - 24 - 36 - 48 - 110	6 - 12 - 24 - 36 - 48 - 110	6 - 12 - 24 - 36 - 48 - 110 - 220
Voltage ranges VAC	6 - 12 - 24 - 120 - 230	6 - 12 - 24 - 120 - 230	6 - 12 - 24 - 120 - 230	6 - 12 - 24 - 120 - 230
Insulation Coil / Contact	2000/1200 VAC	2000/1200 VAC	2000/1200 VAC	2000/1200 VAC
Consumption	DC=0.9 W - AC=1.2 VA	DC=0.9 W - AC=1.2 VA	DC=1.4 W - AC=2 VA	DC=1.5 W - AC=2.5 VA
Approvals / Conformity	CE - cURus - CSA - TÜV	CE - cURus - CSA - TÜV	CE - cURus - CSA - TÜV	CE - cURus - CSA - TÜV

References

6 VDC	RPYA0016	RPYA0026	RPYA0036	RPYA0046
12 VDC	RPYA00112	RPYA00212	RPYA00312	RPYA00412
24 VDC	RPYA00124	RPYA00224	RPYA00324	RPYA00424
36 VDC	RPYA00136	RPYA00236	RPYA00336	RPYA00436
48 VDC	RPYA00148	RPYA00248	RPYA00348	RPYA00448
110 VDC	RPYA001110	RPYA002110	RPYA003110	RPYA004110
6 VAC	RPYA001A6	RPYA002A6	RPYA003A6	RPYA004A6
12 VAC	RPYA001A12	RPYA002A12	RPYA003A12	RPYA004A12
24 VAC	RPYA001A24	RPYA002A24	RPYA003A24	RPYA004A24
120 VAC	RPYA001A120	RPYA002A120	RPYA003A120	RPYA004A120
230 VAC	RPYA001A230	RPYA002A230	RPYA003A230	RPYA004A230
Options	Consult your Carlo Gavazzi partner or distributor			

Midi industrial relays sockets

Types	ZPY08A	ZPY11A	ZPY14A
			





General specifications

Dimensions HxWxD (mm)	27.8 x 30 x 69.8	27.8 x 40 x 69.8	27.8 x 50.5 x 69.8
Rated volt. / Rated curr.	10 A @ 300 VAC	10 A @ 300 VAC	10 A @ 300 VAC
Insulation voltage	> 4 kV	> 4 kV	> 4 kV
Socket material	PA6 - V2	PA6 - V2	PA6 - V2
Mounting	DIN-rail	DIN-rail	DIN-rail
Degree of protection	IP 00	IP 00	IP 00
Approvals	CE - cURus - CSA	CE - cURus - CSA	CE - cURus - CSA

References

Consult your Carlo Gavazzi Partner or Distributor	For Relays: RPYA 001 and RPYA 002	For Relays: RPYA 003	For Relays: RPYA 004
---	-----------------------------------	----------------------	----------------------

Midi and Slim industrial relays

	Midi industrial relays		Slim industrial relays	
Types	RPYS 001	RPYS 002	RSLM100	RSLM001
				
Dimensions HxWxD (mm)	28 x 29 x 12.6	28 x 29 x 12.6	15 x 28 x 5	15 x 28 x 5
No. of Contacts	1 Change-over	2 Change-over	1 Normally open	1 Change-over
Contact rating	12 A	8 A	6 A	6 A
Terminal types	Faston or PCB	Faston or PCB	PCB	PCB

Output specifications

Max. load AC1	12 A	8 A	6 A / 250 VAC	6 A / 250 VAC
Min. load	10 mA / 12 VDC	10 mA / 12 VDC	170 mW / 24 VDC 210 mW/ 48~60 VDC	170 mW / 24 VDC 210 mW/ 48~60 VDC
Mechanical endurance	≥ 10, 000, 000 cycles (18000 Ops / h)	≥ 10, 000, 000 cycles (18000 Ops / h)	> 100,000 cycles	> 100,000 cycles
Electrical life	1 x 10 ⁵	1 x 10 ⁵		
Switching power	1/3 HP, 24 0VAC (Motor load)	1/6 HP, 240 VAC (Motor load)	1500 VA	1500 VA

General specifications

Voltage ranges VDC	12 - 24	12 - 24	12 - 24 - 48 - 60	12 - 24 - 48 - 60
Voltage ranges VAC	24 - 115 - 230	24 - 115 - 230		
Insulation Coil / Contact	4000 VAC/1min	4000 VAC/1min		
Consumption	DC (W) approx. 0.53 AC (VA) approx. 1.0	DC (W) approx. 0.53 AC (VA) approx. 1.0	170 mW ~ 210 mW	170 mW ~ 210 mW
Approvals / Conformity	CE - cURus	CE - cURus	cURus - CSA - VDE - CQC	cURus - CSA - VDE - CQC

References

12 VDC	RPYS001012D	RPYS002012D	RSLM100012	RSLM001012
24 VDC	RPYS001024D	RPYS002024D	RSLM100024	RSLM001024
24 VAC	RPYS001024A	RPYS002024A		
48 VDC			RSLM100048	RSLM001048
60 VDC			RSLM100060	RSLM001060
115 VAC	RPYS001115A	RPYS002115A		
230 VAC	RPYS001230A	RPYS002230A		
Options	Consult your Carlo Gavazzi partner or distributor			

Midi industrial relays sockets

Slim relay sockets

Types	ZPYS1S	ZPYS2S	ZRLS1.NA	ZRLS1.GA	ZRLP
					

General specifications

Dimensions HxWxD (mm)	61.5 x 80 x 15.8	61.5 x 80 x 15.8	88 x 55 x 6	101 x 80 x 6	33 x 30 x 6
Rated volt. / Rated curr.	16 A @ 300 VAC	10 A @ 300 VAC	6 A @ 300 VAC	6 A @ 300 VAC	6 A @ 300 VAC
Insulation voltage	4 Kv	4 Kv	> 3 kV	> 3 kV	> 3 kV
Socket material	PA6 - V2	PA6 - V2	PA66 + GF (V0)	PA66 + GF (V0)	PA66 + GF (V0)
Mounting	DIN-rail	DIN-rail	DIN-rail	DIN-rail	PCB
Terminal Type	IPO0	IPO0	Screw cage	Spring loaded	
Approvals	CE - cURus	CE - cURus	CE - cURus - CSA	CE - cURus - CSA	CSA - cURus

References

Consult your Carlo Gavazzi Partner or Distributor	For Relays: RPYS001 and RPYS002				
Input Voltage 6~24 VAC/VDC			ZRLS12NA	ZRLS12GA	
Input Voltage 48~60 VAC/VDC			ZRLS13NA	ZRLS13GA	
Input Voltage 110~125 VAC/VDC			ZRLS14NA	ZRLS14GA	
Input Voltage 220~240 VAC/VDC			ZRLS15NA	ZRLS15GA	

ZRLP

Power relays

Power relays

Types

NB (1/2 Poles)
NF (1/2 Poles)
NP (1/2 Poles)

Dimensions HxWxD (mm)	55 x 50.5 x 54.5	36 x 50.5 x 54.5	36 x 50.5 x 33.5
No. of Contacts	1 Normally open 2 Normally open	1 Normally open 2 Normally open	1 Normally open 2 Normally open
Contact rating	30 A	30 A	30 A
Terminal types	Bolt	Faston	PCB

Output specifications

Max. load AC1	30 A (1NO) - 25 A (2NO)	30 A (1NO) - 25 A (2NO)	30 A (1NO) - 25 A (2NO)
Electrical life	1 x 10 ⁵	1 x 10 ⁵	1 x 10 ⁵
Switching power	7500 VA / 840 W	7500 VA / 840 W	7500 VA / 840 W

General specifications

Voltage ranges VDC	6 - 12 - 24 - 48 - 100 - 110	6 - 12 - 24 - 48 - 100 - 110	6 - 12 - 24 - 48 - 100 - 110
Voltage ranges VAC	12 - 24 - 48 - 115 - 230	12 - 24 - 48 - 115 - 230	12 - 24 - 48 - 115 - 230
Insulation according to	4000 VAC	4000 VAC	4000 VAC
Consumption	DC=1.9 W - AC=2.7 VA	DC=1.9 W - AC=2.7 VA	DC=1.9 W - AC=2.7 VA
Approvals / Conformity	CE - cURus	CE - cURus	CE - cURus

References

	1NO Contact	2NO Contact	1NO Contact	2NO Contact	1NO Contact	2NO Contact
6 VDC	NBD 100 6	NBD 200 6	NFD 100 6	NFD 200 6	NPD 100 6	NPD 200 6
12 VDC	NBD 100 12	NBD 200 12	NFD 100 12	NFD 200 12	NPD 100 12	NPD 200 12
24 VDC	NBD 100 24	NBD 200 24	NFD 100 24	NFD 200 24	NPD 100 24	NPD 200 24
48 VDC	NBD 100 48	NBD 200 48	NFD 100 48	NFD 200 48	NPD 100 48	NPD 200 48
100 VDC	NBD 100 100	NBD 200 100	NFD 100 100	NFD 200 100	NPD 100 100	NPD 200 100
12 VAC	NBA 100 12	NBA 200 12	NFA 100 12	NFA 200 12	NPA 100 12	NPA 200 12
24 VAC	NBA 100 24	NBA 200 24	NFA 100 24	NFA 200 24	NPA 100 24	NPA 200 24
48 VAC	NBA 100 48	NBA 200 48	NFA 100 48	NFA 200 48	NPA 100 48	NPA 200 48
115 VAC	NBA 100 115	NBA 200 115	NFA 100 115	NFA 200 115	NPA 100 115	NPA 200 115
230 VAC	NBA 100 230	NBA 200 230	NFA 100 230	NFA 200 230	NPA 100 230	NPA 200 230
Options	Consult your Carlo Gavazzi partner or distributor					

Power relays

Power relays

CF (2 Poles)



CS (2 Poles)



Dimensions (mm) WxHxD	26.42 x 68.58 x 34.54	26.42 x 52.32 x 34.54
No. of Contacts	2 Normally open 2 Change-over	2 Normally open 2 Change-over
Contact rating	30 A	30 A
Terminal types	Faston	PCB
Output specifications		
Max. load AC1	30 A (2NO) - 30 A (2CO)	30 A (2NO) - 30 A (2CO)
Electrical life	1 x 10 ⁵	1 x 10 ⁵
Switching power	8310 VA / 840 W	8310 VA / 840 W
General specifications		
Voltage ranges VDC	5 - 6 - 12 - 24 - 48 - 110	5 - 6 - 12 - 24 - 48 - 110
Voltage ranges VAC	24 - 120 - 208 - 240 - 277	24 - 120 - 208 - 240 - 277
Insulation according to	4000 VAC	4000 VAC
Consumption	DC=1.7 W - AC=4 VA	DC=1.7 W - AC=4 VA
Approvals / Conformity	cURus	cURus

References

	2NO Contact	2CO Contact	2NO Contact	2CO Contact
5 VDC	CF30 D2005	CF30 D0025	CS30 D2005	CS30 D0025
6 VDC	CF30 D2006	CF30 D0026	CS30 D2006	CS30 D0026
12 VDC	CF30 D20012	CF30 D00212	CS30 D20012	CS30 D00212
24 VDC	CF30 D20024	CF30 D00224	CS30 D20024	CS30 D00224
48 VDC	CF30 D20048	CF30 D00248	CS30 D20048	CS30 D00248
110 VDC	CF30 D200110	CF30 D002110	CS30 D200110	CS30 D002110
24 VAC	CF30 A20024	CF30 A00224	CS30 A20024	CS30 A00224
120 VAC	CF30 A200120	CF30 A002120	CS30 A200120	CS30 A002120
208 VAC (only 60Hz)	CF30 A200208	CF30 A002208	CS30 A200208	CS30 A002208
220 VAC (only 50Hz)	CF30 A200220	CF30 A002220	CS30 A200220	CS30 A002220
240 VAC	CF30 A200240	CF30 A002240	CS30 A200240	CS30 A002240
277 VAC	CF30 A200277	CF30 A002277	CS30 A200277	CS30 A002277
Options	Consult your Carlo Gavazzi partner or distributor			

Sockets for electromechanical relays

Types

ZD 35/2A

ZD 50/2A

ZD 35/3A

ZD 50/3A

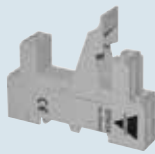
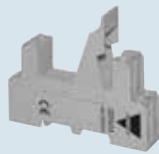

General specifications

Rated volt. / Rated curr.	12 A @ 300 VAC	12 A @ 300 VAC	12 A @ 300 VAC	12 A @ 300 VAC
Insulation voltage	> 5 kV	> 5 kV	> 5 kV	> 5 kV
Socket material	Self-ext. PA6 + GF (V1)	Self-ext. PA6 + GF (V1)	Self-ext. PA6 + GF (V1)	Self-ext. PA6 + GF (V1)
Mounting	DIN-rail	DIN-rail	DIN-rail	DIN-rail
Degree of protection	IP20	IP20	IP20	IP20
Approvals	CE - cURus - CSA (12 A, 300 VAC)	CE - cURus - CSA (12 A, 300 VAC)	CE - cURus - CSA (12 A, 300 VAC)	CE - cURus - CSA (12 A, 300 VAC)

References

For relay:	MZ 1P 5/10 A	MZ B 1P 5/10 A	MZ 1P 5/10 A	MZ B 1P 5/10 A
	M15 M 8 A	MZ 2P 5/10 A	M15 M 8 A	MZ 2P 5/10 A
	M25 1P 12 A	MZ 1P 16 A	M25 1P 12 A	MZ 1P 16 A
	LC 10 A	M15 M 8 A	LC 10 A	M15 M 8 A
		M25 1P 16 A		M25 1P 16 A
		M25 2P 8 A		M25 2P 8 A
	LC 5/16 A		LC 5/16 A	

For detailed information consult your Carlo Gavazzi Partner or Distributor

Hold down spring to be ordered separately:
 • SZD15 for M15/M25 relays
 • SZD20 for LC relays
 • SZD25 for MZ relays

Hold down spring to be ordered separately:
 • SZD15 for M15/M25 relays
 • SZD20 for LC relays
 • SZD25 for MZ relays

Hold down spring to be ordered separately:
 • SZD15 for M15/M25 relays
 • SZD20 for LC relays
 • SZD25 for MZ relays

Hold down spring to be ordered separately:
 • SZD15 for M15/M25 relays
 • SZD20 for LC relays
 • SZD25 for MZ relays

Types

Additional modules for ZMI and ZD sockets



General specifications

Dimensions (mm) WxHxD	23 x 12.5 x 8.5
Terminal material	CuSn
Degree of protection	IP40
Operating temperature	-40°C to +70°C
Ambient humidity	85RH non condensing
Approvals / Conformity	No approvals

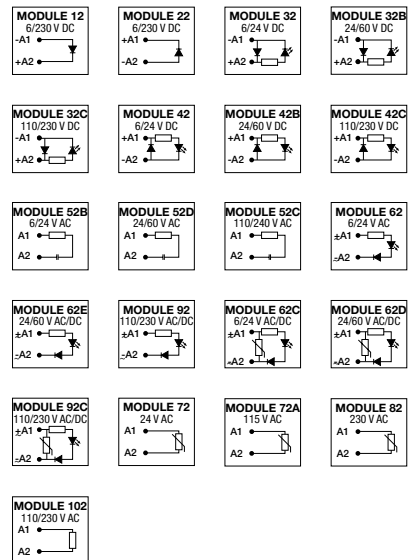

References

Consult your Carlo Gavazzi Partner or Distributor



Switching power supplies

Single-phase switching power supplies

Types	SPD 5 / 10 / 18 W				SPD 30 / 60 W			SPD 90 / 100 W		
										
Dimensions HxWxD (mm)	90 x 22.5 x 114				90 x 40.5 x 114			90 x 54 x 114		
Output specifications										
Voltage	5 VDC	12 VDC	15 VDC	24 VDC	12 VDC	24 VDC	48 VDC	12 VDC	24 VDC	48 VDC
Current SPD 5 W	1 A	420 mA	340 mA	210 mA						
Current SPD 10 W	2 A	840 mA	670 mA	420 mA						
Current SPD 18 W	3 A	1.5 A	1.2 A	750 mA						
Current SPD 30 W					2.5 A	1.25 A	625 mA			
Current SPD 60 W					5 A	2.5 A	1.25 A			
Current SPD 90 W										3.8 A
Current SPD 100 W								8.4 A	4.2 A	2.1 A
Line regulation		±1%				±0.5%				±1%
Load regulation		±2%				±0.5%				±1%
Efficiency	75%	77%	77%	77%	86%	89%	89%			85%
Input specifications										
Voltage range	Multi voltage: 90 to 265 VAC or 120 to 370 VDC				Multi voltage: 85 to 264 VAC or 90 to 375 VDC			Multi voltage: 90 to 264 VAC or 120 to 375 VDC		
Frequency range	47 to 63 Hz				47 to 63 Hz			47 to 63 Hz		
General specifications										
Ambient temperature	-40°C to +71°C				-40°C to +71°C			-35°C to +71°C		
Storage	-40°C to +85°C				-40°C to +85°C			-40°C to +85°C		
Derating (>60°C)	3 % / °C				2.5 % / °C			2.5 % / °C		
Approvals/Marks	CE- cULus- cURus - UL1310 Class 2 - ISA 12.12.1 Class I Div2 - TÜV - CCC				CE- cULus- cURus - UL1310 Class 2 - ISA 12.12.1 Class I Div2 - TÜV - CCC			CE - cULus - cURus, UL1310 Class 2 (up to 90W) - ISA 12.12.1 Class I Div2 - TÜV - CCC		
Installation	DIN-rail				DIN-rail			DIN-rail		
Connection	Screw terminals / Spring terminals (B)				Screw terminals / Spring terminals (B)			Screw terminals / Spring terminals (B)		
Main features										
	Adjustable output voltage. Internal noise filter. Short circuit protection. Overload protection (110-135%)				Adjustable output voltage. Internal noise filter. Short circuit protection. Overload protection (110-135%). Output "Power ready" signal VDC (only model 24 VDC)			Adjustable output voltage. Internal noise filter. Short circuit protection. Overload protection (102-108%), PFC. Overvoltage protection (102-106%). Output "Power ready" signal VDC		
LED indicator for "power on"	Yes				Yes			Yes		
LED indicator for DC "too low"	Yes				No - SPD24 with transistor output			Yes with relay output		
References										
5 VDC										
Screw terminals	SPD05051 / SPD05101 SPD05181									
12 VDC										
Screw terminals	SPD12051 / SPD12101 SPD12181				SPD12301 / SPD12601					
Spring terminals	SPD12101B				SPD12301B / SPD12601B					
24 VDC										
Screw terminals	SPD24051 / SPD24101 SPD24181				SPD24301 / SPD24601			SPD24901L / SPD241001		
Spring terminals	SPD24101B / SPD24181B				SPD24301B / SPD24601B					
48 VDC										
Screw terminals					SPD48301 / SPD48601					

Switching power supplies

Single-phase switching power supplies

Types	SPD 120 W(N)	SPD 240 W	SPD 300 W
			

Dimensions HxWxD (mm)	124.5 x 64 x 123.6	124.5 x 83.5 x 123.6	124.5 x 83.5 x 123.6
-----------------------	--------------------	----------------------	----------------------

Output specifications

Voltage	12 VDC	24 VDC	48 VDC	24 VDC	48 VDC	24 VDC	48 VDC
Current	10 A	5 A	2.5 A	10 A	5 A	12.5 A	6.25 A
Line regulation		±0.5%	±0.5%		±0.5%		±0.5%
Load regulation		±1%	±1%		±1%		±1%
Efficiency	84%	86%	86%	89%	90%	89%	90%

Input specifications

Voltage range	Autoselect: 90 to 132 VAC, 180 to 264 VAC, 120 to 375 VDC	Autoselect: 90 to 132 VAC, 180 to 264 VAC, 120 to 375 VDC	Autoselect: 90 to 132 VAC, 180 to 264 VAC, 120 to 375 VDC
Frequency range	47 to 63 Hz	47 to 63 Hz	47 to 63 Hz
PFC	0.7	0.75	0.75

General specifications

Ambient temperature	-35°C to +71°C	-40°C to +71°C	-30°C to +71°C
Storage	-40°C to +85°C	-40°C to +85°C	-40°C to +85°C
Derating (>60°C)	2.5 % / °C	2.5 % / °C	2.5 % / °C
Approvals/Marks	CE- cULus- cURus - ISA 12.12.1 Class I Div2 - TÜV - CCC	CE- cULus- cURus - ISA 12.12.1 Class I Div2 - TÜV - CCC	CE- cULus- cURus - ISA 12.12.1 Class I Div2 - TÜV - CCC
Installation	DIN-rail	DIN-rail	DIN-rail
Connection	Screw terminals / Detachable (B)	Screw terminals / Detachable (B)	Screw terminals

Main features

	Adjustable output voltage. Internal noise filter. Short circuit protection. Overload protection (110-145%). Parallel connection up to 3 supplies and PFC function on (N) model only	Adjustable output voltage. Internal noise filter. Short circuit protection. Overload protection (110-145%). Parallel connection up to 3 supplies standard. PFC function integrated	Parallel function, PFC and Output ready
LED indicator for "power on"	Yes	Yes	Yes, 24 V with output ready
LED indicator for DC "too low"	Yes - with relay output (SPD24 only)	Yes - with relay output (SPD24 only)	Yes

References

12 VDC			
Screw terminals	SPD121201N		
24 VDC			
Screw terminals	SPD241201N	SPD242401	SPD243001
Detach. screw terminals	SPD241201BN	SPD242401B	
48 VDC			
Screw terminals		SPD482401	

Switching power supplies

Single-phase switching power supplies

Bi-phase switching power supplies

Types

SPD 480 W
SPD 100 W

Dimensions HxWxD (mm)

124.5 x 175.5 x 123.6

90 x 54 x 114

Output specifications

	24 VDC	48 VDC	12 VCC	24 VCC	48 VCC
Voltage	24 VDC	48 VDC	12 VCC	24 VCC	48 VCC
Current	20 A	10 A	8.4 A	4.2 A	2.1 A
Line regulation	±0.5%		±1.0%		
Load regulation	±1%		±1.0%		
Efficiency (typ)	89%	90%	86%	87%	89%

Input specifications

Voltage range	Autoselect: 90 to 132 VAC, 186 to 264 VAC, 120 to 370 VDC	340 to 575 VAC, 480 to 820 VAC
Frequency range	47 to 63 Hz	47 to 63 Hz
PFC	0.99	0.55

General specifications

Ambient temperature	-40°C to +71°C	-40°C to +71°C
Storage	-40°C to +85°C	-40°C to +85°C
Derating (>60°C)	2.5 % / °C > 56°C	2.5% / °C
Approvals/Marks	CE- cULus- cURus - ISA 12.12.1 Class I Div2 - TÜV - CCC	CE- cULus- cURus - ISA 12.12.1 Class I Div2 - TÜV - CCC
Installation	DIN-rail	DIN-rail
Connection	Screw terminals / Detachable (B)	Screw terminals

Main features

Adjustable output voltage.
Internal noise filter.
Short circuit protection.
Overload protection (120-140%).
Parallel connection up to 3 supplies standard.
PFC function integrated

Parallel function, PFC and Output ready

LED indicator for "power on"	Yes	Yes - with relay output (SPD24 only)
LED indicator for DC "too low"	Yes - with relay output (SPD24 only)	Yes

References

24 VDC		
Screw terminals	SPD244801	SPD 241002
Detatch. screw terminals	SPD244801B	
48 VDC		
Screw terminals	SPD484801	

Switching power supplies

Three-phase switching power supplies

Types **SPD 120 W 3-ph** **SPD 240 W 3-ph** **SPD 480 W 3-ph** **SPD 960 W 3-ph**



Dimensions HxWxD (mm) 124 x 74.3 x 118.8 124 x 89.0 x 118.8 124 x 150 x 118.8 126.2 x 275.8 x 118.8

Output specifications

Voltage	12 VDC	24 VDC	24 VDC	48 VDC	24 VDC	48 VDC	24 VDC	48 VDC
Current	10 A	5 A	10 A	5 A	20 A	10 A	40 A	20 A
Line regulation	±1%		±1%		±1%		±1%	
Load regulation	±1%		±1%		±1%		±1%	
Efficiency	87%	89%	90%	91%	90%	91%	92%	93%

Input specifications

Voltage range	340 to 575 VAC 480 to 820 VDC	340 to 575 VAC 480 to 820 VDC	340 to 575 VAC 480 to 820 VDC	340 to 575 VAC 480 to 820 VDC
Frequency range	47 to 63 Hz			
PFC	0.55	0.55	0.65	0.80

General specifications

Ambient temperature	-40°C to +71°C	-25°C to +71°C	-30°C to +71°C	-40°C to +71°C
Storage	-40°C to +85°C			
Derating	2.5 % / °C > 61°C		3.5 % / °C > 61°C	
Approvals/Marks	CE- cULus- cURus - ISA 12.12.1 Class I Div2 - TÜV - CCC	CE- cULus- cURus - ISA 12.12.1 Class I Div2 - TÜV - CCC	CE- cULus- cURus - ISA 12.12.1 Class I Div2 - TÜV - CCC	CE- cULus- cURus - ISA 12.12.1 Class I Div2 - TÜV - CCC
Installation	DIN-rail			
Connection	Screw terminals		Screw terminals	

Main features





	Can be used as Bi or Three-phase, Parallel function and PFC	Can be used as Bi or Three-phase, Parallel function and PFC	Can be used as Bi or Three-phase, Parallel function and PFC	Can be used as Bi or Three-phase. Active parallel function and PFC
LED indicator for "power on"	Yes, 24 V with output ready	Yes, 24 V with output ready	Yes, 24 V with output ready	Yes, 24 V with output ready
LED indicator for DC "too low"	Yes	Yes	Yes	Yes

References

12 VDC				
Screw terminals	SPD121203			
24 VDC				
Screw terminals	SPD241203	SPD242403	SPD244803	SPD249603
48 VDC				
Screw terminals	SPD482403		SPD484803	SPD489603



Switching power supplies

Compact Low profile DIN-rail mounting

Types	SPMA 15 12 W to 15 W	SPMA 30 25 W to 36 W	SPMA 60 54 W to 60 W	SPMA 100 85 W to 100 W
				
Dimensions HxWxD (mm)	91 x 18 x 63	91 x 52.5 x 63	91 x 52.5 x 63	91 x 70 x 63
Output specifications				
Voltage	5 VDC, 12 VDC, 15 VDC, 24 VDC	5 VDC, 12 VDC, 15 VDC, 24 VDC	5 VDC, 12 VDC, 15 VDC, 24 VDC	5 VDC, 12 VDC, 15 VDC, 24 VDC, 24 VDC (S ver.)
Current	2.4 A - 1.25 A 1 A - 0.63 A	6.0 A - 2.1 A 2.0 A - 1.5 A	4.5 A 4.0 A - 2.5 A	7.1 A - 6.12 A 4.2 A - 3.83 A
Output Power	5 V - 12 W, 12 V - 15 W 15 V - 15 W, 24 V - 15 W	5 V - 30 W, 12 V - 25 W 15 V - 30 W, 24 V - 36 W	12 V - 54 W 15 V - 60 W, 24 V - 60 W	12 V - 85 W 15 V - 92 W 24 V - 100 W or 24 V - 92 W (for class 2 compliance)
Line regulation	±0.5%	±0.5%	±0.5%	±0.5%
Load regulation	±1%	±1%	±1%	±1%
Input specifications				
Voltage range	85 to 264 VAC, 120 to 350 VDC	85 to 264 VAC, 120 to 350 VDC	85 to 264 VAC 120 to 350 VDC	85 to 264 VAC, 120 to 350 VDC
Frequency range	47 to 63 Hz	47 to 63 Hz	47 to 63 Hz	47 to 63 Hz
General specifications				
Ambient temperature	-30°C to +70°C	-30°C to +70°C	-30°C to +70°C	-30°C to +70°C
Storage	-40°C to +85°C	-40°C to +85°C	-40°C to +85°C	-40°C to +85°C
Derating (>60°C)	2.5 % / °C	2.5 % / °C	2.5 % / °C	2.5 % / °C
Approvals/Marks	CE - cULus - cURus UL 1310 Class 2 - ISA 12.12.1 Class I Div2	CE - cULus - cURus UL 1310 Class 2 - ISA 12.12.1 Class I Div2	CE - cULus - cURus UL 1310 Class 2 - ISA 12.12.1 Class I Div2	CE - cULus - cURus UL 1310 Class 2 (up to 91.92 W) - ISA 12.12.1 Class I Div2
Installation	DIN-rail	DIN-rail	DIN-rail	DIN-rail
Connection	Screw terminals	Screw terminals	Screw terminals	Screw terminals
Main features				
	Adjustable output voltage	Adjustable output voltage	Adjustable output voltage	Adjustable output voltage
LED indicator for "power on"	Yes	Yes	Yes	Yes
LED indicator for DC "too low"	Yes	Yes	Yes	Yes
References				
5 VDC	SPMA05151	SPMA05301		
12 VDC	SPMA12151	SPMA12301	SPMA12601	SPMA121001
15 VDC	SPMA15151	SPMA15301	SPMA15601	SPMA151001
24 VDC	SPMA24151	SPMA24301	SPMA24601	SPMA241001
24 VDC (Not UL Class 2)				SPMA241001S

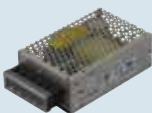
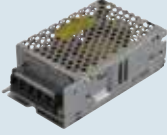

Switching power supplies

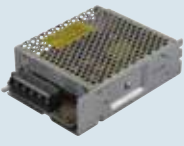
Enclosed switching power supplies

Types	SPPC 25 W	SPPC 35 W	SPPC 50 W	SPPC 75 W
				
Dimensions HxWxD (mm)	79 x 51 x 28.8	101.6 x 63.5 x 33	99 x 82 x 35	129 x 98 x 38
Output specifications				
Voltage	5 V, 12 V, 24 V	5 V, 12 V, 24 V	5 V, 12 V, 15 V, 24 V, 48 V	5 V, 12 V, 24 V, 48 V
Current	5 A, 2.1 A, 1.1 A	6 A, 3 A, 1.5 A	8 A, 4.2 A, 3.4 A, 2.2 A, 1.12 A	12 A, 6 A, 3.2 A, 1.62 A
Line regulation	±0.5%	±0.5%	±0.5%	±0.5%
Load regulation	±2.0%, ±1.0%, ±1.0%	±1.0%	±1.0%	±2.0%
Efficiency (typ)	115 VAC 230 VAC	76%, 80%, 84% 78%, 82%, 85%	79%, 83%, 86% 80%, 84%, 87%	79%, 84%, 87%, 88% 80%, 85%, 88%, 89%
Input specifications				
Voltage range	90 to 264 VAC 127 to 370 VDC	90 to 264 VAC 127 to 370 VDC	90 to 264 VAC 27 to 370 VDC	90 to 264 VAC 127 to 370 VDC
Frequency range	47 to 63 Hz	47 to 63 Hz	47 to 63 Hz	47 to 63 Hz
General specifications				
Ambient temperature	-25°C to +70°C	-25°C to +70°C	-25°C to +70°C	-25°C to +70°C
Storage	-40°C to +85°C	-40°C to +85°C	-40°C to +85°C	-40°C to +85°C
Derating (>50°C)	2% / °C	2% / °C	1.5% / °C	1.5% / °C
Cooling	Free air convection	Free air convection	Free air convection	Free air convection
Approvals/Marks	CE - cURus	CE - cURus	CE - cURus	CE - cURus
Installation	Screw terminal	Screw terminal	Screw terminal	Screw terminal
Main features				
Mounting	Horizontal and vertical (DIN-rail mounting accessories available)	Horizontal and vertical (DIN-rail mounting accessories available)	Horizontal and vertical (DIN-rail mounting accessories available)	Horizontal and vertical (DIN-rail mounting accessories available)
References				
5 VDC	SPPC 525 1	SPPC 535 1	SPPC 550 1	SPPC 575 1
12 VDC	SPPC 1225 1	SPPC 1235 1	SPPC 1250 1	SPPC 1275 1
15 VDC			SPPC 1550 1	
24 VDC	SPPC 2425 1	SPPC 2435 1	SPPC 2450 1	SPPC 2475 1
48 VDC			SPPC 4850 1	SPPC 4875 1



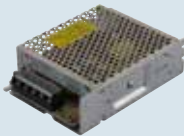
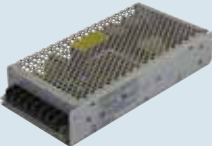

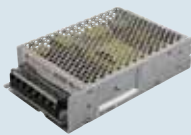
Switching power supplies

Compact enclosed switching power supplies

Types	SPPC 100 W	SPPC 150 W	SPPC 150 W (PFC) Power Factor Correction	SPPC 150 W PFC Compact
				
Dimensions HxWxD (mm)	129 x 98 x 38	199 x 98 x 38	194 x 99 x 50	160 x 98 x 38
Output specifications				
Voltage	5 V, 12 V, 24 V, 48 V	5 VDC, 12 VDC, 15 VDC, 24 VDC, 48 VDC	5 VDC, 12 VDC, 15 VDC, 24 VDC, 48 VDC	5 VDC, 12 VDC, 15 VDC, 24 VDC, 48 VDC
Current	20 A, 8.5 A, 4.2 A, 2.2 A	26 A, 12.5 A, 10 A, 6.5 A, 3.3 A	30 A, 12.5 A, 10 A, 6.3 A, 3.2 A	12.5 A, 10 A, 6.3 A, 3.2 A
Line regulation	±0.5%	±0.5%	±0.5%	±0.5%
Load regulation	±2% (5, 12 V) ±1% (24, 48 V)	±1%	±1%	±2%, ±2%, ±1%, ±1%
Efficiency (typ)	84%, 87%, 88%, 88%	up to 85%	up to 87%	86%, 87%, 87%, 88%
Built-in active PFC			PFC > 0.98 @ 115 VAC; PFC > 0.95 @ 230 VAC	Active PFC, PF > 0.95
Input specifications				
Voltage range	90 to 264 VAC 127 to 370 VDC	88 to 132 VAC 176 to 264 VAC 124 to 186 VDC 248 to 370 VDC	88 to 264 VAC 124 to 370 VDC	90 to 264 VAC 120 to 370 VDC
Frequency range	47 to 63 Hz	47 to 63 Hz	47 to 63 Hz	47 - 63 VAC
General specifications				
Ambient temperature	-25°C to +70°C	-25°C to +70°C	-25°C to +70°C	-20°C to +70°C
Storage	-40°C to +85°C	-40°C to +85°C	-30°C to +85°C	-30°C to +85°C
Output short circuit		Long-term, auto recovery	Long-term, auto recovery	Long-term, auto recovery
Derating (>50°C)	See derating curve	2.5% / °C	2.5% / °C	Refer to derating diagram
Cooling	Free air convection	Free air convection	Free air convection	Free air convection
Approvals/Marks	CE - cURus	CE - cURus	CE - cURus	CE - cURus
Installation	Screw terminal	Screw terminal	Screw terminal	Screw terminal
Main features				
Mounting	Horizontal and vertical (DIN-rail mounting accessories available)	Horizontal and vertical (DIN-rail mounting accessories available)	Horizontal and vertical (DIN-rail mounting accessories available)	Horizontal and vertical (DIN-rail mounting accessories available)
References				
5 VDC	SPPC5100 1	SPPC5150 1	SPPC5150 1F	
12 VDC	SPPC12100 1	SPPC12150 1	SPPC12150 1F	SPPC12150 1FC
15 VDC		SPPC15150 1	SPPC15150 1F	SPPC15150 1FC
24 VDC	SPPC24100 1	SPPC24150 1	SPPC24150 1F	SPPC24150 1FC
48 VDC	SPPC48100 1	SPPC48150 1	SPPC48150 1F	SPPC48150 1FC



Switching power supplies

Compact enclosed switching power supplies

Types	SPPC 200 W	SPPC 240 W	SPPC 320 W	SPPC 480 W
				
Dimensions HxWxD (mm)	199 x 99 x 50	199 x 99 x 50	199 x 99 x 50	218 x 116.5 x 41
Output specifications				
Voltage	5 V, 12 V, 24 V, 48 V	12 V, 24 V	5 V, 12 V, 24 V, 48 V	12 V, 24 V, 36 V, 48 V
Current	40 A, 16.7 A, 8.4 A, 4.2 A	20 A, 10 A	55 A, 25 A, 13 A, 6.7 A	34 A, 22 A, 14 A, 11 A
Line regulation	±0.5%	±0.5%	±0.5%	±0.5%, ±0.5%, ±0.5%, ±0.2%
Load regulation	±1.0%	±1.0%	±1.0%	±1.0%
Efficiency (typ)	79%, 84%, 86%, 87.5%	84%, 86%	79%, 84.5%, 87%, 87.5%	88%, 89%, 90%, 90%
Built-in active PFC	(115 VAC): PF>0.98 (230 VAC): PF>0.96	(115 VAC): PF>0.98 (230 VAC): PF>0.96	(115 VAC): PF>0.98 (230 VAC): PF>0.96	(115 VAC): PF>0.98 (230 VAC): PF>0.96
Input specifications				
Voltage range	85 to 264 VAC 120 to 370 VDC	85 to 264 VAC 120 to 370 VDC	85 to 264 VAC 120 to 370 VDC	90 to 264 VAC 127 to 370 VAC
Frequency range	47 to 63 Hz	47 to 63 Hz	47 to 63 Hz	47 to 63 Hz
General specifications				
Ambient temperature	-25°C to +70°C	-25°C to +70°C	-25°C to +70°C	-30°C to +70°C
Storage	-40°C to +85°C	-40°C to +85°C	-40°C to +85°C	-40°C to +85°C
Output short circuit	Long-term, auto recovery	Long-term, auto recovery		
Derating (>50°C)	2% / °C	2% / °C	2% / °C	2% / °C
Cooling	Forced air (built-in DC fan controlled by load and internal temperature)	Forced air (built-in DC fan controlled by load and internal temperature)	Forced air (built-in DC fan controlled by load and internal temperature)	Forced air (built-in DC fan controlled by load and internal temperature)
Approvals/Marks	CE - cURus	CE - cURus	CE - cURus	CE - cURus
Installation	Screw terminal	Screw terminal	Screw terminal	Screw terminal
Main features				
Mounting	Horizontal and vertical (DIN-rail mounting accessories available)	Horizontal and vertical (DIN-rail mounting accessories available)	Horizontal and vertical (DIN-rail mounting accessories available)	Horizontal and vertical (DIN-rail mounting accessories available)
References				
5 VDC	SPPC5200 1FC		SPPC5320 1FC	
12 VDC	SPPC12200 1FC	SPPC12240 1FC	SPPC12320 1FC	SPPC12480 1FC
15 VDC				SPPC24480 1FC
24 VDC	SPPC24200 1FC	SPPC24240 1FC	SPPC24320 1FC	SPPC36480 1FC
48 VDC	SPPC48200 1FC		SPPC48320 1FC	SPPC48480 1FC



Switching power supplies

Compact enclosed switching power supplies

Types	SPPC 600 W	SPPC 800 W
		
Dimensions HxWxD (mm)	218 x 116.5 x 41	226 x 116.5 x 41
Output specifications		
Voltage	12 V, 24 V, 36 V, 48 V	24 V, 48 V
Current	(100 to 127 VAC): 34 A, 22 A, 14 A, 11 A (128 to 264 VAC): 42 A, 26.5 A, 17.5 A, 13.6 A	(100 to 127 VAC): 27 A, 14 A (128 to 264 VAC): 33 A, 16.5 A
Line regulation	±0.5%	±0.5%
Load regulation	±1.0%	±1.0%
Efficiency (typ)	88%, 89%, 90%, 90%	88%, 89%
Built-in active PFC	(115 VAC): PF>0.98 (230 VCA): PF>0.96	(115 VAC): PF>0.98 (230 VAC): PF>0.96
Input specifications		
Voltage range	90 to 264 VAC 127 to 370 VAC	90 to 264 VAC 127 to 370 VAC
Frequency range	47 to 63 Hz	47 to 63 Hz
General specifications		
Ambient temperature	-30°C to +70°C	-30°C to +70°C
Storage	-40°C to +85°C	-40°C to +85°C
Output short circuit	Yes	Yes
Derating (>50°C)	2% / °C	2% / °C
Cooling	Forced air (built-in DC fan controlled by load and internal temperature)	Forced air (built-in DC fan controlled by load and internal temperature)
Approvals/Marks	CE - cURus	CE - cURus
Installation	Screw terminal	Screw terminal
Main features		
Mounting	Horizontal and vertical (DIN-rail mounting accessories available)	Horizontal and vertical (DIN-rail mounting accessories available)
References		
12 VDC	SPPC12600 1FC	
15 VDC	SPPC24600 1FC	SPPC 24800 1FC
24 VDC	SPPC36600 1FC	
48 VDC	SPPC48600 1FC	SPPC 48800 1FC



Switching power supplies

Compact DIN-rail power supplies

Types	SPDM 30 W	SPDM 50 W	SPDM 75 W
			
Dimensions HxWxD (mm)	90 x 22.4 x 100	90 x 30 x 100	90 x 40.5 x 100
Output specifications			
Voltage	12 V, 24 V	12 V, 24 V	12 V, 24 V
Current	2 A (12 V) 1.25 A (24 V)	4 A (12 V) 2.1 A (24 V)	5.5 A (12 V) 3 A (24 V)
Line regulation	±1.0%	±1.0%	±1.0%
Load regulation	±1.0%	±1.0%	±1.0%
Efficiency (typ)	85% to 89%	85% to 89%	85% to 89%
Input specifications			
Voltage range	85 to 264 VAC 120 to 375 VDC	85 to 264 VAC 120 to 375 VDC	85 to 264 VAC 120 to 375 VDC
Frequency range	47 to 63 Hz	47 to 63 Hz	47 to 63 Hz
General specifications			
Ambient temperature	-25°C to +70°C	-25°C to +70°C	-25°C to +70°C
Storage	-40°C to +85°C	-40°C to +85°C	-40°C to +85°C
Output short circuit	Yes	Yes	Yes
Derating (>50°C)	Refer to datasheet	Refer to datasheet	Refer to datasheet
Cooling	Natural air convection	Natural air convection	Natural air convection
Approvals/Marks	CE - cULus - UL1310 Class 2	CE - cULus - UL1310 Class 2	CE - cULus - UL 1310 Class 2 only for 24 VDC models (SPDM24751 and SPDM24751B)
Installation	DIN-rail	DIN-rail	DIN-rail
Connection	Screw or Spring terminals	Screw or Spring terminals	Screw or Spring terminals
Main features			
LED indicator for "DC OK"	Yes	Yes	Yes
References			
12 VDC			
Screw terminals	SPDM12301	SPDM12501	SPDM12751 (Not UL Class 2)
24 VDC			
Screw terminals	SPDM24301	SPDM24501	SPDM24751
Spring terminals	SPDM24301B	SPDM24501B	SPDM24751B



Switching power supplies

Compact DIN-rail power supplies

Types	SPDM 120 W	SPDM 240 W
		
Dimensions HxWxD (mm)	124 x 45 x 119	124 x 70 x 127
Output specifications		
Voltage	12 V, 24 V, 48 V	24 V, 48 V
Current	10 A (12 V) 5 A (24 V) 2.5 A (48 V)	10 A (24 V) 5 A (48 V)
Line regulation	±0.5%	±0.5%
Load regulation	±1.0%	±1.0%
Efficiency (typ)	85% (12 V) 88% (24 V) 89% (48 V)	87% (24 V) 88% (48 V)
Input specifications		
Voltage range	90 to 264 VAC 127 to 370 VDC	90 to 264 VAC 127 to 370 VDC
Frequency range	47 to 63 Hz	47 to 63 Hz
General specifications		
Ambient temperature	-20°C to +70°C	-20°C to +70°C
Storage	-40°C to +85°C	-40°C to +85°C
Output short circuit	Yes	Yes
Derating (>50°C)	Refer to datasheet	Refer to datasheet
Cooling	Natural air convection	Natural air convection
Approvals/Marks	CE - cULus - cURus	CE
Installation	DIN-rail	DIN-rail
Connection	Screw terminals	Screw terminals
Main features		
LED indicator for "DC OK"	Yes	Yes
References		
12 VDC	SPDM121201	
24 VDC	SPDM241201	SPDM242401
48 VDC	SPDM481201	SPDM482401

Switching power supplies

High compactness DIN-rail power supplies

Types	SPDC 120 W	SPDC 240 W	SPDC 480 W
			
Dimensions HxWxD (mm)	124 x 32 x 119	124 x 45 x 119	124 x 70 x 127
Output specifications			
Voltage	12 V, 24 V	24 V	24 V, 48 V
Current	10 A, 5 A	10 A	20 A, 10 A
Line regulation	±0.5%	±0.5%	±0.5%
Load regulation	±1.0%	±1.0%	±1.0%
Efficiency (typ)	From 89.5% to 91%	88.00%	93.80%
Built-in active PFC	>0.95	>0.95	>0.95
Input specifications			
Rated input voltage	100 VAC - 240 VAC	100 VAC - 240 VAC	100 VAC - 240 VAC
Voltage range	85 to 264 VAC 127 to 360 VDC	85 to 264 VAC 127 to 375 VDC	85 to 264 VAC 130 to 350 VDC
Frequency range	47 to 63 Hz	47 to 63 Hz	47 to 63 Hz
General specifications			
Ambient temperature	-25°C to 70°C	-25°C to 70°C	-25°C to 70°C
Storage	-40°C to 85°C	-40°C to 85°C	-40°C to 85°C
Output short circuit	Yes	Yes	Yes
Derating (>50°C)	Refer to datasheet diagram	Refer to datasheet diagram	Refer to datasheet diagram
Cooling	Free air convection	Free air convection	Free air convection
Approvals/Marks	CE - cULus - cURus	CE - cULus - cURus	CE - cULus - cURus
Installation	DIN-rail	DIN-rail	DIN-rail
Connection	Screw terminals	Screw terminal	Screw terminal
Main features			
DC OK Out	SPST relay	SPST relay	SPST relay
References			
12 VDC	SPDC121201		
24 VDC	SPDC241201	SPDC242401	SPDC244801
48 VDC			SPDC484801

Switching power supplies, redundancy modules

Redundancy modules

Types

SPD Redundancy module



Dimensions HxWxD (mm) 90 x 54 x 114

Output specifications

Voltage 24 VDC

Current 20 A

Input specifications

Voltage range 21 to 28 VDC

General specifications

Ambient temperature -40°C to +71°C

Storage -40°C to +85°C

Approvals/Marks cULus - cURus - TÜV - CE

Installation DIN-rail

Connection Screw terminals

Main features



LED indicator for "power on" Yes - with relay output (SPD24 only)

Features 2 Relay outputs for remote monitoring

References

24 VDC SPD24RM20

Switching power supplies, backup systems

	UPS controller	Switching power supply and UPS
Types	SPUC	SPUBC
		
Dimensions HxWxD (mm)	90 x 54 x 114	115 x 65 x 135
Output specifications		
Voltage	12 / 24 VDC	24 VDC
Charging voltage	12 V Model: Min. 9.1 VDC ~ 13.75 VDC Max. 24 V Model: Min. 18.7 VDC ~ 28 VDC Max.	27.5 VDC (Std.), 28.8 VDC (Boost)
Power supply current	30 A	5 A + 5 A with battery charged + 5 A for 4 s
Charging current max	2.5 A	5 A
Input specifications		
Rated voltage input	12 / 24 VDC	115 VAC, 230 VAC, 277 VAC
Voltage range	12 V Model: 11 VDC to 14 VDC 24 V Model: 22.5 VDC to 28 VDC	90 to 305 VAC
Frequency range		47 to 63 Hz
General specifications		
Ambient temperature	-40°C to +71°C	-25°C to +70°C
Storage	-40°C to +85°C	-40°C to +85°C
Derating (+51°C to +70°C)	2.5% /°C	Refer to datasheet diagram
Cooling	Free air convection	Free air convection
Approvals/Marks	CE - cULus - cURus - TÜV	CE - cURus
Installation	Screw terminal	Screw terminal
Main features		
Mounting	DIN-rail mounting	DIN-rail mounting
Battery diagnostics	No	Yes
DC OK Out	Yes	Yes
Battery OK Out	Yes	Yes
Mains / Backup Out	Yes	Yes
References		
12 V 30 A max	SPUC12360	
24 V 30 A max	SPUC24720	
PS + UPS 24 V 120 W		SPUBC24120

Switching power supplies, backup systems

Low profile DIN battery charger

Battery racks for UPS and chargers

Types

SPM5BC

SPUBAT 24V



Dimensions HxWxD (mm)

91 x 90 x 57

175 x 62 x 120
200 x 82 x 160
210 x 145 x 130
210 x 210 x 210

Output specifications

Voltage	12 V / 24 V	24 VDC
Charging voltage	13.6 VDC / 27.2 VDC	
Power supply current	30 W / 60 W	
Charging current max	1.25 A - 2.5 A 30 W / 2.5 A - 5 A 60 W	120 mA, 320 mA, 720 mA, 1.2 A
Battery capacity		1.2 / 3.2 / 7.2 / 12 Ah
Battery type		AGM VRLA

Input specifications

Rated voltage input	110 VAC / 240 VAC	24 V
Voltage range	90 to 264 VAC 120 to 375 VDC	27.5 @ 20°C 26.8 @ 30°C 26.1 @ 40°C VDC End of charge voltage (trickle)
Frequency range	47 to 63 Hz	
Max charging current		0.36 / 0.9 / 2.16 A

General specifications

Ambient temperature	-40°C to +51°C	0°C to +40°C
Storage	-40°C to +85°C	0°C to +40°C
Derating (+51°C to +70°C)	Refer to datasheet diagram	
Cooling	Free air convection	Free air convection
Approvals/Marks	CE -TÜV	CE
Installation	Screw terminal	Screw terminal

Main features

Mounting	Horizontal and vertical (DIN-rail mounting accessories available)	Wall / DIN-rail mounting
Battery diagnostics	No	
DC OK Out	No	
Battery OK Out	No	
Mains / Backup Out	Yes	

References

12 V 30 W	SPM5BC 1230	
24 V 30 W	SPM5BC 2430	
12 V 60 W	SPM5BC 1260	
24 V 60 W	SPM5BC 2460	
24 V 1.2 Ah Battery		SPUBAT241A2
24 V 3.2 Ah Battery		SPUBAT243A2
24 V 7.2 Ah Battery		SPUBAT247A2
24 V 12 Ah Battery		SPUBAT2412A

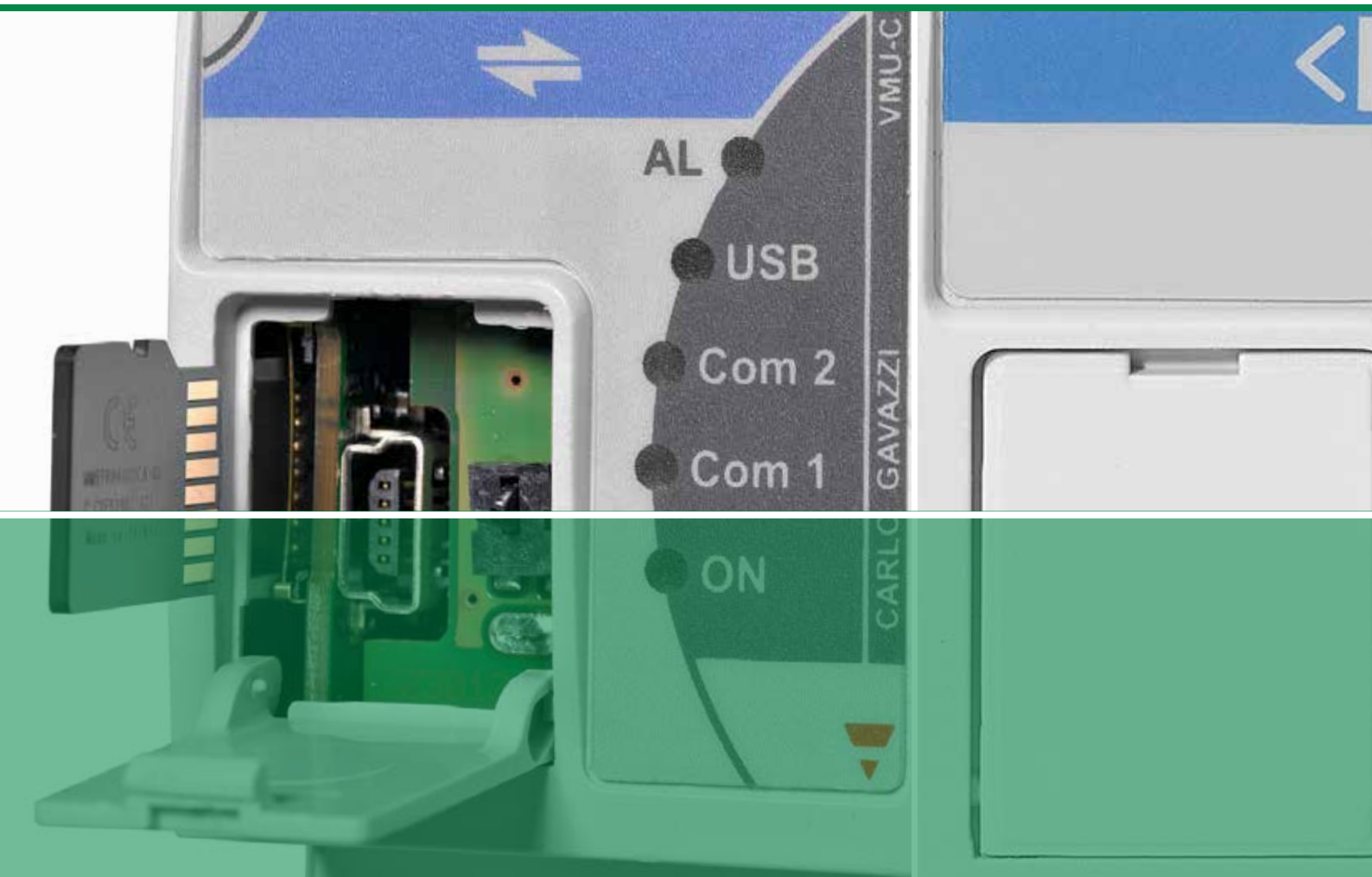

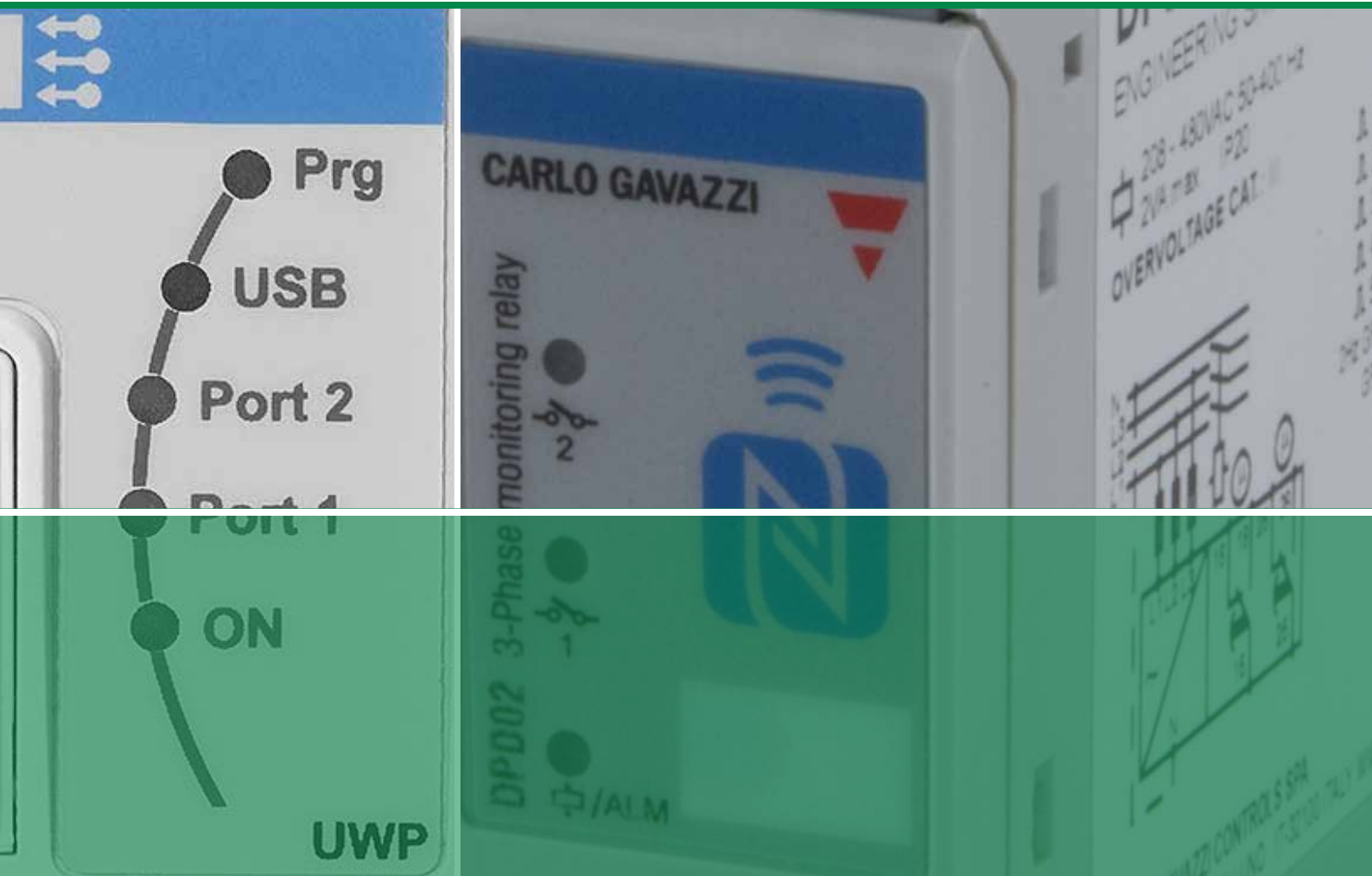

Controls





Digital panel meters	212
Energy/Power analyzers	216
Current transformers	226
Data aggregation solutions	235
PV monitoring solutions	240
Building automation	244
Parking guidance system	263
DuplineSafe	267
Fieldbuses	271
Monitoring relays	283
Timers	296

Digital panel meters

Ammeters, voltmeters and frequency meters

Types	DI3 DIN	DI3 72	LDI 3
			
Dimensions HxWxD (mm)	89 x 52.5 x 58.5	72 x 72 x 75.5	48 x 96 x 83
Function	3-digit meter. 1-phase AC, DC. Voltmeter, ammeter frequency meter	Microprocessor based indicator. AC / DC ammeter, voltmeter. Freq. meter 3-digit display red LED. Height: 14.2 mm	Microprocessor based indicator. AC / DC ammeter, voltmeter. Freq. meter 3-digit display
Input specifications			
Range code	1 A / 100 VAC [AV1] 5 A / 500 VAC [AV5] 1 A / 60 mV / 100 V / 500 VDC [AV6] 1 Hz to 1000 Hz [F1K]	[AV1]: 1 AAC / 100 VAC [AV5]: 5 AAC / 500 VAC [AV6]: 1 ADC / 60 mV / 100 V / 500 VDC	[AV1]: 1 AAC / 100 VAC [AV5]: 5 AAC / 500 VAC [AV6]: 1 ADC / 60 mV / 100 V / 500 VDC [F1K]: 1 to 1000 Hz
Accuracy	0.5% FS (0.1% FS frequency meter)	±0.5% FS	±0.5% FS (±0.3% FS frequency meter)
Indication	Max.	999 [AV1 / AV5] 000 [AV1 / AV5]	999
	Min.	000 [AV1 / AV5] -99 [AV6]	000 [AV1 / AV5] -99 [AV6]
Range selection / decimal point pos.	Selectable by DIP-switch	Selectable by DIP-switch	Selectable by DIP-switch
Display refresh time	1 time/s	1 time/s	1 time/s
General specifications			
Power supply	24 VAC [A], 48 VAC [B], 115 VAC [C], 230 VAC [D]	24 VAC [A], 48 VAC [B], 115 VAC [C], 230 VAC [D]	24 VAC [A], 48 VAC [B], 115 VAC [C], 230 VAC [D]
Option		IP65[EX]	IP65[IX], tropicalization [XT]
Safety Standards	EN 61010-1, IEC 61010-1, VDE0411	EN 61010-1, IEC 61010-1, VDE0411	EN 61010-1, IEC 61010-1, VDE0411
Approvals/Marks	CE - CSA	CE - CSA	CE - c CSA us

Digital panel meters

	Ammeters and voltmeters		Thermometer and ohmmeter
Types	LDI 35 AV0	LDI 35 AV2	LDI 35 CF
			
Dimensions HxWxD (mm)	48 x 96 x 83	48 x 96 x 83	48 x 96 x 83
Function	Microprocessor based indicator/controller, AC / DC ammeter, voltmeter, 3½-digit or 3-digit + dummy zero display	Microprocessor based indicator/controller, AC / DC ammeter, voltmeter, 3½-digit or 3-digit + dummy zero display	Microprocessor based indicator/controller, Temperature resistance Measur. in C° or F° 3½-digit or 3-digit + dummy zero display
Input specifications			
Range code	Current: 2 mA DC, 20 mA DC Voltage: 200 mV DC, 20 VDC, 200 VDC [AV0]	Current: 2 AAC/DC, 5 AAC/DC Voltage: 200 VAC/DC, 500 VAC/DC [AV2]	Pt100, Ni100 [CFX]; Pt1000 [CFP]; TC-J-LK-S-T [CFX/CFP]; 200.0Ω [CFX]; 2000Ω [CFP]
Accuracy	±0.3% FS	DC: ±0.3% FS, AC: ±0.5% FS	TC, PT100/1000, resistance ±0.3% FS Ni 100 ±0.5% FS
Indication	Max. 3½-dgt: 1999, 3+0-dgt: 9990 Min. 3½-dgt: -1999, 3+0-dgt: -1990	3½-dgt: 1999, 3+0-dgt: 9990 3½-dgt: -1999 (DC), 0 (AC), 3+0-dgt: -1990 (DC), 0 (AC)	Depending on range and type of the temperature probe
Resistance			0 to 200 Ω (2000 Ω)
Range election / decimal point pos.	Programmable	Programmable	Programmable
Display refresh time	4 times/s	4 times/s	4 times/s
Functions			
	Password protection. Scaling factor. Diagnostics. Digital filter programm. Max. data hold.	Password protection. Scaling factor. Diagnostics. Digital filter programm. Max. data hold.	Password protection. Scaling factor. Diagnostics. Digital filter programm. Max. data hold.
Output specifications			
Setpoints	1 optional alarm [1] 5 A / 250 VAC/DC Excit. output 40 mA / 15 VDC [AX]	1 optional alarm [1] 5 A / 250 VAC/DC Excit. output 40 mA / 15 VDC [AX]	1 optional alarm [1] 5 A / 250 VAC/DC Excit. output 40 mA / 15 VDC [AX]
General specifications			
Power supply	120 [E], 230 [D], 240 [F], 24 [A], 48 [B], 115 [C] VAC, 9 - 32 [3] VDC, 40 - 150 [6] VDC	120 [E], 230 [D], 240 [F], 24 [A], 48 [B], 115 [C] VAC, 9 - 32 [3] VDC, 40-150 [6] VDC	120 [E], 230 [D], 240 [F], 24 [A], 48 [B], 115 [C] VAC, 9 - 32 [3] VDC, 40-150 [6] VDC
Option	IP65[IX], excit. out [AX], tropicalization [XT]	IP65[IX], excit. out [AX], tropicalization [XT]	IP65[IX], excit. out [AX], tropicalization [XT]
Safety Standards	EN 61010-1, IEC 61010-1, VDE0411	EN 61010-1, IEC 61010-1, VDE0411	EN 61010-1, IEC 61010-1, VDE0411
Approvals/Marks	CE - c CSA us	CE - c CSA us	CE - c CSA us

Digital panel meters

Ammeters and voltmeters

Types

LDM 30

LDM 35 H

LDM 40



Dimensions HxWxD (mm)	48 x 96 x 83	48 x 96 x 83	48 x 96 x 83
Function	3-dgt + dummy 0 μ P-based indicator, red LED display	3 1/2-dgt μ P-based indicator and controller, 3 1/2-dgt or 3-dgt + dummy 0 red LED display	4-dgt μ P-based indicator and controller

Input specifications

Range code	1 A / 100 VAC [AV1]; 5 A / 500 VAC [AV5]	(0.2-2-20 mA, 0.2-2-20 V) [LSE]; (0.2- 2-5 A, 20-200-500 V) [HSX]; DC and AC TRMS	(0.2-2-20 mA, 0.2-2-20 V) [LSE]; (0.2- 2-5 A, 20-200-500 V) [HSX]; DC and AC TRMS
Accuracy	$\pm 0.5\%$ FS, ± 1 -dgt	DC: $\pm(0.3\%$ RDG + 3-dgt) AC: $\pm(0.5\%$ RDG + 3-dgt)	DC: $\pm(0.1\%$ RDG + 2-dgt) AC: $\pm(0.3\%$ RDG + 2-dgt)
Indication	Max.	9990	9999
	Min.	000	0 (AC) -9999 (DC) 4-dgt LED red
Range selection / decimal point pos.	Selectable by dipswitch	Programmable	Programmable
Display refresh time	2 times/s	5 times/s	5 times/s

Functions

Signal / display scaling.
Digital filter. Peak and valley.

Output specifications

Up to 2 Alarm relays, [1-2]

Up to 2 Alarm relays, [1-2],
Analogue 0 to 20 mA,
0 to 10 V [AV],
RS485

General specifications

Power supply	24 / 48 VAC [B], 115 / 230 VAC [D]	90 to 260 VAC/DC [H], 18 to 60 VAC/DC [L]	90 to 260 VAC/DC [H], 18 to 60 VAC/DC [L]
Option	Tropicalization [XT], IP65 [IX]	Tropicalization [TX]	Tropicalization [T]
Safety Standards	EN61010-1 IEC61010-1	EN61010-1 IEC61010-1	EN61010-1 IEC61010-1
Approvals/Marks	CE - cURus - cCSAus	CE - cURus - cCSAus	CE - cURus - cCSAus

Digital panel meters

Modular meter and conditioner

Types	UDM 35	UDM 40	USC
			

Dimensions HxWxD (mm)	48 x 96 x 105	48 x 96 x 105	44 x 113 x 107
Function	MODULAR Microprocessor-based indicator / controller AC/DC Ammeter / Voltmeter / Resistance / temperature measurement	MODULAR Microprocessor-based indicator / controller AC/DC Ammeter / Voltmeter / Resistance / temperature measurement	MODULAR Microprocessor-based converter / controller AC/DC Ammeter / Voltmeter / Resistance / temperature measurement

Input specifications

Range code	0.2-2-20 mA DC/AC 0.2-2-20 VDC/AC [LSX] + AUX 13 VDC [LSE] or 25 VDC [LSF]; 0.2-2-5 A DC/AC; 20-200-500 V DC/AC [HSX]; TC: J-K-S-T-E, Pt100-250-500-1000 [TRX]; 0.02-0.2-2-20 kΩ [TRX] 0.001 Hz to 50 Hz for DC signal [TF1] 0.001 Hz to 50 Hz for AC signal [TF2]	0.2-2-20 mA DC/AC 0.2-2-20 VDC/AC [LSX] + AUX 13 VDC [LSE] or 25 VDC [LSF]; 0.2-2-5 A DC/AC; 20-200-500 VDC/AC [HSX]; TC: J-K-S-T-E, Pt100-250-500-1000 [TRX]; 0.02-0.2-2-20 kΩ [TRX] 0.001 Hz to 50 Hz for DC signal [TF1] 0.001 Hz to 50 Hz for AC signal [TF2]	0.2-2-20 mA DC/AC 0.2-2-20 VDC/AC [LSX] + AUX 13 VDC [LSE] or 25 VDC [LSF]; 0.2-2-5 A DC/AC; 20-200-500 VDC/AC [HSX]; TC: J-K-S-T-E, Pt100-250-500-1000 [TRX]; 0.02-0.2-2-20 kΩ [TRX] 0.001 Hz to 50 Hz for DC signal [TF1] 0.001 Hz to 50 Hz for AC signal [TF2]
Accuracy	0.1% RDG	0.1% RDG	0.1% RDG
Indication	Max.	1999	9999
	Min.	0 (AC) -1999 (DC), 3 ½-dgt LED red	0 (AC) -9999 (DC), 4-dgt LED. Colours: red, green, orange
Range selection / decimal	Programmable	Programmable	
Display refresh time	5 times/s	5 times/s	5 times/s

Functions

	Password protection. Scaling factor. Min Max data storage. Programmable digital filter Analog signal re-transmission Range selection. Programmable via PC.	Password protection. Scaling factor. Min Max data storage. 16 linearization points. Programm. digital filter. Analog signal re-transmission Range selection. Programmable via PC.	Password protection. Scaling factor. Min Max data storage. 16 linearization points. Programm. digital filter. Analog signal re-transmission Range selection. Programmable via PC.
--	--	--	--

Output specifications



Setpoints	Analogue 0 to 20 mA, 0 to 10 V [AV] Serial RS485 [SX], Serial RS232 [SY], Single relay output [R1], Dual relay output [R2], Dual relay + dual open coll. output [R4], Four relay output [R5]	Analogue 0 to 20 mA, 0 to 10 V [AV] Serial RS485 [SX], Serial RS232 [SY], Single relay output [R1], Dual relay output [R2], Dual relay + dual open coll. output [R4], Four relay output [R5]	Analogue 0 to 20 mA, 0 to 10 V [AV] Serial RS485 [SX], Serial RS232 [SY], Single relay output [R1], Dual relay output [R2], Dual relay + dual open coll. output [R4], Four relay output [R5]
-----------	--	--	--

General specifications

Power supply	90 to 260 AC/DC [H], 18 to 60 VAC/DC [L] 10 to 28 VDC [3]	90 to 260 AC/DC [H], 18 to 60 VAC/DC [L] 10 to 28 VDC [3]	90 to 260 AC/DC [H], 18 to 60 VAC/DC [L] 10 to 28 VDC [3]
Option	Tropicalization [TX]	Tropicalization [TX]	Tropicalization [TX]
Safety Standards	EN 61010-1, IEC 61010-1	EN 61010-1, IEC 61010-1	EN 61010-1, IEC 61010-1
Approvals/Marks	CE - cURus - cCSAus	CE - cURus - cCSAus	CE - cURus - cCSAus



Energy analyzers

Energy analyzers

Types	EM110	EM111	EM112
			
Dimensions HxWxD (mm)	90 x 18 x 63	90 x 18 x 63	90 x 36 x 63
Description	1-phase kWh meter 1-DIN module	1-phase energy analyzer with Touch Tech technology 1-DIN module	1-phase energy analyzer with Touch Tech technology 2-DIN modules
Function	kWh	V_{LN} , A, Hz, $\pm W$, W_{dmd} , $W_{dmd\ max}$, $\pm var$, PF, $\pm kWh$, $\pm kvarh$, kWh+ by tariff (2) TRMS method	V_{LN} , A, Hz, $\pm W$, W_{dmd} , $W_{dmd\ max}$, $\pm var$, PF, $\pm kWh$, $\pm kvarh$, kWh+ by tariff (2) TRMS method
Input specifications			
Range code	120 VAC [AV7] 230 VAC [AV8] Ib: 5 A, I _{max} : 45 AAC; 1-phase	120 VAC [AV7] 230 VAC [AV5, AV8] I _{nom} : 32A; I _{max} : 45 AAC; 1-phase [AV7, AV8] I _{nom} : 5A; I _{max} : 6 AAC; 1-phase [AV5]	120 VAC [AV1] 230 VAC [AV0] Ib: 5 A, I _{max} : 100 AAC; 1-phase
Accuracy	n.a.	$\pm 0.5\%$ RDG (V, A)	$\pm 0.5\%$ RDG (V, A)
Active energy	Class 1 (EN62053-21) Class B (EN50470-3)	Class 1 (EN62053-21) Class B (EN50470-3)	Class 1 (EN62053-21) Class B (EN50470-3)
Reactive energy	n.a.	Class 2 (EN62053-23)	Class 2 (EN62053-23)
Display	Electromechanical 6+1 dgt (energy)	Backlit LCD with touch keypad 4-dgt (inst. variables) 5+2, 6+1, 7-dgt (energies)	Backlit LCD with touch keypad and supercapacitor backup (up to 48h) up to 2 x 4-dgt (inst. variables) 6+2, 7+1, 8-dgt (energies)
Output specifications			
Pulse output	1-open collector [O1]	1-open collector [AV7, AV8] [O1]	1-open collector [O1]
Alarm output			
Communication		Modbus RTU [S1] M-bus [AV7, AV8] [M1]	Modbus RTU [S1] M-bus [M1]
Inputs		1 (dual tariff management)	1 (dual tariff management)
General specifications			
Power supply	Self power supply [X]	Self power supply [X]	Self power supply [X]
Approvals/Marks	CE - MID - cULus [AV7 only]	CE - MID [AV8 only] - cULus [AV7 only]	CE - MID - cULus [AV1 only]

Energy analyzers

Energy analyzers

Types	EM330	EM340	EM24 DIN
			
Dimensions HxWxD (mm)	90 x 54 x 63	90 x 54 x 63	90 x 72 x 67
Description	3-phase energy analyzer with Touch Tech technology and wrong connection detection 3-DIN modules	3-phase energy analyzer with Touch Tech technology and wrong connection detection 3-DIN modules	3-phase energy analyzer 4 DIN modules
Function	System: \pm kWh, \pm kvarh, kWh+ by tariff (2), V _{LN} , V _{LL} , PF, Hz, \pm W, W _{dmd} , W _{dmd max} , \pm var, VA, h Single-phase: kWh, V _{LN} , V _{LL} , A, PF, W, var, VA TRMS method	System: \pm kWh, \pm kvarh, kWh+ by tariff (2), V _{LN} , V _{LL} , PF, Hz, \pm W, W _{dmd} , W _{dmd max} , \pm var, VA Single-phase: kWh, V _{LN} , V _{LL} , A, PF, W, var, VA TRMS method	System: \pm kWh, \pm kvarh, V _{LN} , V _{LN} , var, VA, W _{dmd} , W, VA _{dmd} , Hz hour counter, gas and water Max: A _{dmd} , W _{dmd} , VA _{dmd} Single-phase: V _{LN} , V _{LL} , A, W, var, VA, PF, kWh, kvarh TRMS method

Input specifications

Range code	3-phase 400-480 V _{LL} AC [AV5] I _b : 5 A, I _{max} : 6 AAC; 3-phase	3-phase 208-400 V _{LL} AC [AV2] I _b : 5 A, I _{max} : 65 AAC; 3-phase	120 / 208 V _{LL} [AV6]; 400 V _{LL} [AV5] In: 1 / 5 A, I _{max} : 10 AAC [AV5 and AV6]; 208/400 V _{LL} [AV2] I _b : 10 A, I _{max} : 65 AAC [AV2]
Accuracy	\pm 0.5% RDG (V, A)	\pm 0.5% RDG (V, A)	\pm 0.5% RDG (V, A)
Active energy	Class 1 (EN62053-21) Class B (EN50470-3)	Class 1 (EN62053-21) Class B (EN50470-3)	Class 1 (EN62053-21) Class B (EN50470-3)
Reactive energy	Class 2 (EN62053-23)	Class 2 (EN62053-23)	Class 2 (EN62053-23)
Display	Backlit LCD with touch keypad 3x 4-dgt (inst. variables) 3x 6+2, 7+1, 8-dgt (energies)	Backlit LCD with touch keypad 3x 4-dgt (inst. variables) 3x 6+2, 7+1, 8-dgt (energies)	LCD 3x 4-dgt (inst. variables) 6+2, 7+1, 8-dgt (energies)





Output specifications

Pulse output	1-open collector [O1]	1-open collector [O1]	2-open collector [O2]; Relay [R2]
Alarm output			2-open collector [O2]; Relay [R2]
Communication	Modbus RTU [S1] M-bus [MT]	Modbus RTU [S1] M-bus [MT]	Modbus RTU [IS] Modbus Ethernet [E1] M-BUS [Mx] Wireless M-BUS [W1] Dupline [DP]
Inputs	1 (dual tariff management)	1 (dual tariff management)	3 digital inputs [IS]



General specifications

Power supply	90 to 260 VAC/DC [H]	Self power supply [X]	Self power supply [X]. Auxiliary power supply: 18 to 60 VAC/DC [L], 115 / 230 VAC [D], according to the model [AV5, AV6]
Approvals/Marks	CE - cULus - MID	CE - MID	CE - cULus [AV5 and AV6] - MID [X..PF..]



Energy analyzers

Energy transducers				Compact transducers
Types	ET112	ET330	ET340	CPT DIN Basic and Advanced
				
Dimensions HxWxD (mm)	90 x 36 x 63	90 x 54 x 63	90 x 54 x 63	83.5 x 45 x 98.5
Description	1-phase energy transducer 2-DIN modules	3-phase energy transducer with wrong connection detection 3-DIN modules	3-phase energy transducer with wrong connection detection 3-DIN modules	3-phase compact power transducer
Function	V_{LN} , A, Hz, $\pm W$, W_{dmd} , $W_{dmd\ max}$, $\pm var$, PF, $\pm kWh$, $\pm kvarh$, $kWh+$ by tariff (2) TRMS method	System: $\pm kWh$, $\pm kvarh$, $kWh+$ by tariff (2), V_{LN} , V_{LL} , PF, Hz, $\pm W$, W_{dmd} , $W_{dmd\ max}$, $\pm var$, VA Single-phase: kWh , V_{LN} , V_{LL} , A, PF, W, var, VA, TRMS method	System: $\pm kWh$, $\pm kvarh$, $kWh+$ by tariff (2), V_{LN} , V_{LL} , PF, Hz, $\pm W$, W_{dmd} , $W_{dmd\ max}$, $\pm var$, VA Single-phase: kWh , V_{LN} , V_{LL} , A, PF, W, var, VA, TRMS method	4-digit data format instantaneous variable, 8+1-digit format energies, 5+2-digit format hours TRMS method System: kWh , $kvarh$, V_{LL} , V_{LN} , An, PF, W, var, VA, W_{dmd} , V_{Admd} , Hz, hour meter Max: W_{dmd} , V_{Admd} [Adv] Single-phase: V_{LL} , V_{LN} , A, A_{dmd} , PF, W, var, VA, THD (A, V) [Adv] Max [Adv]: V_{LN} , A, A_{dmd} , W Min [Adv]: V_{LN} , A, PF
Input specifications				
Range code	120 VAC [AV1] 230 VAC [AV0] Ib: 5 A, I _{max} : 100 AAC; 1-phase	3-phase 400-480 V _{LL} AC [AV5] Ib: 5 A, I _{max} : 6 AAC; 3-phase	3-phase 208-400 V _{LL} AC [AV2] Ib: 5 A, I _{max} : 65 AAC; 3-phase	120 / 208 VAC [AV6], 400 / 690 VAC [AV5], 1 AAC and 5 AAC
Accuracy	$\pm 0.5\%$ RDG (V, A)	$\pm 0.2\%$ RDG (V, A)	$\pm 0.5\%$ RDG (V, A)	$\pm 0.5\%$ RDG (A, V)
Active energy	Class 1 (EN62053-21)	Class 0.5S (EN62053-22)	Class 1 (EN62053-21)	kWh: Class 1 (EN62053-21)
Reactive energy	Class 2 (EN62053-23)	Class 2 (EN62053-23)	Class 2 (EN62053-23)	kvarh: Class 2 (EN62053-23)
Output specifications				
Pulse output				2 (open collector) [O2 Advanced]
Alarm output				2 (relays) with PLC-type control function on 16 variables (AND / OR) [R2 Advanced]
Analogue output				Up to 3: 20 mA [A1-3 Advanced], 10 VDC [V1-3 Advanced]
Communication	Modbus RTU [S1]	Modbus RTU [S1]	Modbus RTU [S1]	RS422/485 [S1], RS232 [S2]
Inputs	1 (dual tariff management)	1 (dual tariff management)	1 (dual tariff management)	
General specifications				
Power supply	Self power supply [X]	Self power supply [X]	Self power supply [X]	18 to 60 VAC/DC [L], 90 to 260 VAC/DC [H]
Approvals/Marks	CE	CE - cULus	CE	CE - cURus - CSA





Energy analyzers

	Energy meters	Energy analyzers	
Types	EM21 72R	EM210 AV	EM210 MV
			
Dimensions HxWxD (mm)	72 x 72 x 65	72 x 72 x 65	72 x 72 x 65
Description	3-phase energy meter 4-DIN modules and 72 x 72 panel mounting	3-phase energy analyzer 4-DIN modules and 72 x 72 panel mounting	3-phase energy analyzer 4-DIN modules and 72 x 72 panel mounting
Function	System: kWh, kvarh, W, var, PF, Hz, Phase sequence Single-phase: V _{LN} , V _{LL} , A, PF, TRMS method	System: ±kWh, kvarh, W, var, PF, An and h-meter (only [X]), Phase-sequence Single-phase: V _{LL} , V _{LN} , A, PF, THD (V, A, up to 15 th H. THD only [X]) TRMS method	System: ±kWh, kvarh, W, var, PF, An, h-meter, Phase-sequence Single-phase: V _{LL} , V _{LN} , A, PF, THD (V, A, up to 15 th H.) TRMS method
Input specifications			
Range code	120 / 230 VAC, 400 VAC 3-phase current input by included current sensors (three ranges available: 90 A - 150 A - 250 A)	120 / 230 VAC, 400 VAC In: 5 A; I _{max} : 6 A (current connection by CT)	120 / 230 VAC, 400 VAC By 333 mV CT [CTV] or by Rogowski sensors [ROG4K]
Accuracy	±0.5% RDG (V) ±1% RDG (A)	±0.5% RDG (V, A)	±0.5% RDG (V, A)
Active energy	Class 2 (EN62053-21)	Class 1 (EN62053-21) Class B (EN50470-3)	Class 1 (EN62053-21)
Reactive energy		Class 2 (EN62053-23)	Class 2 (EN62053-23)
Display	LCD 3 dgt (inst. variables) 6+1, 7 dgt (energies)	LCD 3 dgt (inst. variables) 6+1, 7 dgt (energies)	LCD 3 dgt (inst. variables) 6+1, 7 dgt (energies)
Output specifications			
Pulse output	1 static opto-mosfet	1 static opto-mosfet	1 static opto-mosfet
Communication	RS485 (2-wire, Modbus) M-BUS by means of VMU-B	RS485 (2-wire, Modbus)	RS485 (2-wire, Modbus)
General specifications			
Power supply	Self power supply	Self power supply [X] Universal power supply 90-260 VAC/DC [H] (MID version)	Self power supply
Approvals/Marks	CE - cULus	CE - cULus - MID [PF]	CE - cULus



Quick-fit energy meters

	Quick-fit dual energy meters	3-phase current transformers	Panel adapter for energy meters
Types	EM270	TCD X	EM200-96 Adapter
			
Dimensions HxWxD (mm)	72 x 72 x 65	TCD1X: 72 x 75 x 66.8 TCD2X: 72 x 105 x 50 TCD3X: 78 x 135 x 50	96 x 96 x 41.4
Description	3-phase energy meter 4-DIN modules and 72 x 72 panel mounting	3-phase current transformers for EM270 quick fit meter. Connection to the meter by means of RJ11 connector (included).	Adapter frame from 72 x 72 mm to 96 x 96 mm panel mounting. Installation by fixing brackets included in the meter.
Function	System: kWh, kvarh, kW, kvar Single-phase: kWh, W, W _{dmd} , W _{dmd max} , A, V _L , V _{LN} Virtual sum of the two 3-phase or six 1-phase loads TRMS method	Suitable to be installed downstream the circuit breakers (same width). Automatic setting of the CT ratio in the meter	Suitable for EM210, EM270, EM271, EM280, EM21-72D, EM21-72R, EM21-72V
Input specifications			
Range	120 / 230 VAC, 400 VAC In: from 160 to 630 A by TCD X	TCD1X: 160 A TCD2X: 250 A TCD3X: 630 A	
Accuracy	±0.5% RDG (V, A)	Equivalent to Class 0.5 (IEC61869-2)	
Active energy	Equivalent to Class 1 (EN62053-21)		
Reactive energy	Equivalent to Class 2 (EN62053-23)		
Display	LCD 3-dgt (inst. variables) 6+1, 7-dgt (energies)		
Output specifications			
Pulse output	2 static opto-mosfet		
Communication	RS485 (2-wire, Modbus) M-BUS by means of VMU-BM2...B		
General specifications			
Power supply	Self power supply	n.a.	
Approvals/Marks	CE - cULus	CE - cULus (with EM 270)	CE



Quick-fit energy meters

	Quick-fit dual energy meters	3-phase current transformers	Quick-fit 6-channel energy meters	6-channel current transformer blocks
Types	EM271	TCD M	EM280	TCD06B
				
Dimensions HxWxD (mm)	72 x 72 x 65	TCD0M: 3 by 26 x 40 x 26, hole 9.6 TCD1M: 3 by 31 x 46 x 31, hole 15.7 TCD2M: 3 by 41 x 66 x 38, hole 15.5 TCD3M: 3 by 50 x 78 x 39, hole 20.5	72 x 72 x 65	TCD06BX (solid core): 118 x 53 x 34, hole 7.0, hole centre distance 17.5 TCD06BS (split core): 118 x 45 x 59, hole 8.5, hole centre distance 17.5
Description	Quick-fit energy meter with daisy chaining of voltage and serial connections and fast RJ connection of TCD M 3-phase split-core current sensors, for retrofit applications. Managing of two 3-phase or six 1-phase loads. 4-DIN modules and 72 x 72 panel mounting	TCD M: 3-phase split core current sensors for EM271 quick-fit meter. Connection to the meter by means of RJ11 connector (included). TCDMM: adaptor for 3 CT by 333 mV up to 10000 A	Quick-fit energy meter with daisy chaining of voltage and serial connections and fast RJ connection of TCD06B 6-channel current transformer block. Managing of two 3-phase or six 1-phase loads. 4-DIN modules and 72 x 72 panel mounting	6-channel current transformer blocks with hole centre distance 17.5 mm (same of miniature circuit breakers) for EM280 quick-fit meter. Connection to the meter by means of RJ11 connector (included)
Function	System: kWh, kvarh, kW, kvar Single-phase: kWh, W, W _{dmd} , W _{dmd max} , A, V _{LL} , V _{LN} Virtual sum of the two 3-phase or six 1-phase loads TRMS method	Suitable to be installed in any existing installation. Automatic setting of the CT ratio in the meter	System: kWh, kvarh, kW, kvar Single-phase: kWh, W, W _{dmd} , W _{dmd max} , A, V _{LL} , V _{LN} Virtual sum of the two 3-phase or six 1-phase loads TRMS method	Suitable to be installed in any new and existing installation. Automatic setting of the CT ratio in the meter
Input specifications				
Range	120 / 230 VAC, 400 VAC In: from 60 to 400 A by TCD M	TCD0M: 60 A TCD1M: 100 A TCD2M: 200 A TCD3M: 400 A TCDMM: suitable to be connected to standard CT up to 10 kA	120 / 230 VAC, 400 VAC In: 32 A by TCD06BX and TCD06BS	TCD06B: 32 A
Accuracy	±0.5% RDG (V, A)	Equivalent to Class 1 (IEC61869-2)	±0.5% RDG (V, A)	Equivalent to Class 0.5 (IEC61869-2)
Active energy	Equivalent to Class 1 (EN62053-21)		Equivalent to Class 1 (EN62053-21)	
Reactive energy	Equivalent to Class 2 (EN62053-23)		Equivalent to Class 2 (EN62053-23)	
Display	LCD 3-dgt (inst. variables) 6+1, 7-dgt (energies)		LCD 3-dgt (inst. variables) 6+1, 7-dgt (energies)	
Output specifications				
Pulse output	2 static opto-mosfet		2 static opto-mosfet	
Communication	RS485 (2-wire, Modbus)		RS485 (2-wire, Modbus)	
General specifications				
Power supply	Self power supply		Self power supply	
Approvals/Marks	CE - cULus	CE - cULus (with EM271)	CE - cULus	CE - cULus (with EM280)





Power analyzers

	Self-addressing Quick-fit energy transducers	Power analyzers
Types	ET272	WM15 96
		
Dimensions HxWxD (mm)	72 x 72 x 65	96 x 96 x 59
Description	Self-addressing quick-fit energy transducer with fast RJ connection of TCD M 3-phase split-core current sensors, for retrofit or new applications. Managing of two 3-phase or six 1-phase loads. 4-DIN modules mounting	3-phase power analyzer 96 x 96 panel mounting
Function	Innovative self-addressing Modbus function (it requires VMU-C EM) System: kWh, kvarh, kW, kvar Single-phase: kWh, W, W _{dmd} , W _{dmd max} , A, V _{LL} , V _{LN} Virtual sum of the two 3-phase or six 1-phase loads TRMS method	System: ±kWh, ±kvarh, V _{LL} , V _{LN} , var, VA, W, W _{dmd} , VA _{dmd} , VA, PF, Hz, THD, ± hour counter Max: A _{dmd} , W _{dmd} , VA _{dmd} Single-phase: V _{LL} , V _{LN} , A, W, var, VA, PF, A _{dmd} , kWh TRMS method
Input specifications		
Range code	230 VAC, 400 VAC In: from 60 to 400 A by TCD M up to 10000 A by TCDMM	277 / 415 V _{LL} AC [X], 347 / 600 V _{LL} AC [H], In: 5 A, I _{max} : 6 ACA
Accuracy	±0.5% RDG (V, A)	±0.5% RDG (V, A)
Active energy	Equivalent to Class 1 (EN62053-21)	Class 1 (EN62053-21)
Reactive energy	Equivalent to Class 2 (EN62053-23)	Class 2 (EN62053-23)
Display		Matrix LCD backlight up to 4x 4-dgt (inst. variables) 3x 8+2-dgt (energies)
Output specifications		
Pulse output		1 open collector [OX or OS]
Alarm output		1 open collector [OX or OS]
Communication	RS485 (2-wire, Modbus)	RS485 (2-wire) [OS] M-BUS by means of VMU-B
General specifications		
Power supply	Self power supply	Self power supply [X] 120 to 240 VAC/DC [H]
Approvals/Marks	CE - cULus	CE - cULus - MID [X power supply]



Power analyzers

	Modular power analyzers		Modular power quality analyzers	
Types	WM20 96		WM30 96	
				
				
Dimensions HxWxD (mm)	96 x 96 x 50		96 x 96 x 50	
Description	3-phase modular power quality analyzer 96 x 96 panel mounting		3-phase modular power quality analyzer 96 x 96 panel mounting	
Function	System: total/partial \pm kWh and \pm kvarh, V_{LN} , V_{LL} , VA, W, var, PF, Hz, THD (V,A) Single-phase: V_{LN} , V_{LL} , VA, Al, An, W, var, PF, THD Phase-sequence-asymmetry loss		System: total/partial \pm kWh and \pm kvarh, V_{LN} , V_{LL} , VA, W, var, PF, Hz, THD (V,A) Single-phase: V_{LN} , V_{LL} , VA, Al, An, W, var, PF, THD Phase-sequence-asymmetry loss	
			System: Total/partial \pm kWh and \pm kvarh (multi-tariff), V_{LN} , V_{LL} , VA, W, var, PF, Hz, THD, K-factor Single-phase: V_{LN} , V_{LL} , VA, Al, An (calculated or measured), W, var, PF, THD, TDD; Phase sequence- asymmetry-loss Load profile, event stamping, data logger, utility and hour counters	
Input specifications				
Range code	400 / 690 V _{LL} AC 1(2) AAC [AV4] 400 / 690 V _{LL} AC 5(6) AAC [AV5] 100 / 208 V _{LL} AC 5(6) AAC [AV6] 100 / 208 V _{LL} AC 1(2) AAC [AV7]		400 / 690 V _{LL} AC 1(2) AAC [AV4] 400 / 690 V _{LL} AC 5(6) AAC [AV5] 100 / 208 V _{LL} AC 5(6) AAC [AV6] 100 / 208 V _{LL} AC 1(2) AAC [AV7]	
Accuracy	\pm 0.2% RDG (V, A)		\pm 0.2% RDG (V, A)	
Active energy	Class 0.5S according to EN62053-22		Class 0.5S according to EN62053-22	
Reactive energy	Class 2 according to EN62053-23		Class 2 according to EN62053-23	
Display	LCD backlight 3x 4-dgt (inst. variables) 8+2, 9+1, 10-dgt (energies)		LCD backlight 4x 4 dgt (inst. variables) 8+2, 9+1, 10 dgt (energies)	
Output specifications				
Pulse output	Up to 2 digital outputs		Up to 2 digital outputs	
Alarm output	Up to 2 freely configurable virtual alarms		Up to 4 freely configurable virtual alarms	
Communication	Optical port Modbus RS485/232 port, BACnet SMTP [B3], Modbus TCP Ethernet port [E2], BACnet-IP [B1], Profibus [P1]		Optical port Modbus RS485/232 port, BACnet SMTP [B3], Modbus TCP Ethernet port [E2], BACnet-IP [B1], Profibus [P1]	
Analogue output			Up to 2	
Inputs			Up to 4	
			Up to 6 digital inputs	
General specifications				
Power supply	18 to 60 VAC/DC [L], 90 to 260 VAC/DC [H]		18 to 60 VAC/DC [L], 90 to 260 VAC/DC [H]	
Approvals/Marks	CE - cULus		CE - cULus	

Power analyzers

	Modular branch circuit analyzers	12-channel current transformer blocks	Wiring system for WM50	Optical communication interface
Types	WM50 96	TCD12 BS	TCD12 WS	OPTOPROG
				
Dimensions HxWxD (mm)	96 x 96 x 50	221 x 58 x 49,50		52 x 17.5 x 50.8
Description	96-channel branch circuit analyzer 96 x 96 panel mounting	Split-core CT block for WM50: hole 8.5, hole centre distance 17.5	Wiring system for WM50 branch circuit monitoring system	
Function	Mains power analysis and single branch circuit measurement Mains, system: Total/partial \pm kWh and \pm kvarh (multi-tariff), V _{LN} , V _{LL} , VA, W, var, PF, Hz, THD, K-factor Mains, Single-phase: V _{LN} , V _{LL} , VA, Al An (calculated or measured), W, var, PF, THD, TDD; Phase sequence-asymmetry-loss, event stamping, utility and hour counters Single branch channels: A, W, var, VA, PF, kWh, THD (A), daily min and max for 1 of the above variables	12-channel current transformer blocks with hole centre distance 17.5 mm (same as miniature circuit breakers) for WM50 branch circuit analyzer. Connection to the meter by means of dedicated cable [TCD12WS]	Set of cables to connect WM50 with TCD12BS and 2 consecutive TCD12BS'	Bluetooth and USB interface for meters and analysers with optical port
Input specifications				
Range code	208..480 V _{LL} AC 5(6) AAC [AV5]	Nominal 32 AAC (max 65 AAC)	[030]: 30 cm length cable [050]: 50 cm length cable [100]: 100 cm length cable [200]: 200 cm length cable [500]: 500 cm length cable	
Accuracy	\pm 0.2% RDG (V, A), mains	\pm 0.5% RDG (A), branch channels		
Active energy	Mains: Class 0.5S according to EN62053-22 Branch channels: Class 2 according to EN62053-21			
Reactive energy	Class 2 according to EN62053-23			
Display	LCD backlight 4x 4 dgt (inst. variables) 8+2, 9+1, 10 dgt (energies), only mains			
Output specifications				
Pulse output	Up to 6 digital outputs			
Alarm output	Up to 16 freely configurable virtual alarms			
Communication	Optical port Modbus RS485/232 port [S1], Modbus TCP Ethernet port [E2]	High speed communication to WM50		
Inputs	Up to 6 digital inputs			
Port				
Port 1 - connections				Bluetooth, Micro-USB
Port 2 - connections				Optical
General specifications				
Power supply	100 to 277 VAC/DC	Power supply from WM50		Battery
Approvals/Marks	CE - cULus	CE - cULus (with WM50)	CE - cULus (with WM50)	CE, FCC, IC, Bluetooth 4.0

DC Energy meters

	Contactless power analyzers		Energy analyzers	
Types	CPA050/CPA300	CPA300-V	VMU-E	VMU-X
				
Dimensions HxWxD (mm)	CPA050 63 x 46 x 25 (without connectors) CPA300 99 x 89 x 30 (without connectors)	99 x 89 x 30 (without connectors)	1-DIN module	1-DIN module
Description	Contactless power analyzers	Contactless current transducer for PV installations up to 1500 VDC	DC energy analyzer: V, A, W, kWh	Power supply and communication module for VMU-E unit
Function	CPA monitors electrical variables (V, A, W, var, VA, kWh, PF, HZ, THD) in 1-phase AC (from 1 to 400 Hz) or DC systems	CPA monitors electrical variables (A,Ah) in 1-phase AC (from 1 to 400 Hz) or DC systems		
Input specifications				
Range code	One current input (Hall effect): 50 AAC/50 ADC [CPA300] 300 AAC/400 ADC One voltage input: 800 VAC/1000 VDC	One current input (Hall effect): 300 AAC/400 ADC	400 VDC 20 ADC [AV00] (up 1000 ADC by external shunt 120 mV) 400 VDC 1000 ADC [AV10] (by 10 VDC current sensor)	
Accuracy	±0.5%F.S. (V, A, W)	±0.5%F.S. (A)	±0.5% RDG (V, A)	
Active energy			Class 1	
Display	Front LED to show the Power-ON status of the device	Front LED to show the Power-ON status of the device	LCD 6 dgt	
Output specifications				
Pulse output			1 opto-mosfet through VMU-X unit [X]	1 opto-mosfet
Alarm output	Virtual alarm detection of over-range voltage and over-range current	Virtual alarm detection of over-range current	1 opto-mosfet through VMU-X unit [X]	1 opto-mosfet
Communication	RS485 Modbus RTU	RS485 Modbus RTU	RS485 Modbus RTU through VMU-X unit [X]	RS485 Modbus RTU
Analogue output		Programmable scale 0-10 Vdc		
General specifications				
Power supply	9 to 30 VDC power supply	9 to 30 VDC power supply	Self power supply through VMU-X unit [X]	38 to 265 VAC/DC [U]
Approvals/Marks	CE - cURus	CE - cURus	CE	CE

Current transformers

Current transformers

Types

CTD 1Z



TADK



TADK2



Dimensions HxWxD (mm)

76 x 44 x 31

115.5 x 75 x 44

115.5 x 75 x 44

Input specifications

	Current transformer 1-phase AC	Current transformer 1-phase AC	Current transformer 1-phase AC
Operating frequency	50/60 Hz	50/60 Hz	50/60 Hz
Max. system voltage	0.72 kV	0.72 kV	0.72 kV
Rated insulation level	3 kV / 1 min @ 50 Hz	3 kV/1 min @ 50 Hz	3 kV/1 min @ 50 Hz
Security factor	≤ 5	≤ 5	≤ 5

Output specifications

	5 A	5 A standard (1 A on request)	5 A standard (1 A on request)
Secondary current			





General specifications

Class	1 / 3	0.5	0.5
Bus-bar size (mm) [diameter]	[22]	no (wound primary)	25 x 5 (fixed bar)
Standards	EN 61869-2	CE	CE

Primary current

	Burden (VA)		Burden (VA)		Burden (VA)		
	Class	1	3	Class	0.5	Class	0.5
Accuracy class depending on the burden of the secondary circuit	50 A		1.5	1 A	10	1 A	10
	100 A	1.5		5 A	10	5 A	10
	125 A	2.5		10 A	10	10 A	10
	150 A	2.5		15 A	10	15 A	10
	200 A	3.75		25 A	10	25 A	10
				40 A	10	40 A	10
						50 A	10
						60 A	10
						80 A	10
						100 A	10
						150 A	10
						200 A	10
						250 A	10



Current transformers

Current transformers															
Types	CTD 1X			CTD 2X			CTD 3X			CTD 4X					
															
Dimensions HxWxD (mm)	66 x 46 x 30			86 x 56 x 42			109 x 77 x 42			113 x 90 x 42					
Input specifications															
	Current transformer 1-phase AC			Current transformer 1-phase AC			Current transformer 1-phase AC			Current transformer 1-phase AC					
Operating frequency	50/60 Hz			50/60 Hz			50/60 Hz			50/60 Hz					
Max. system voltage	0.72 kV			0.72 kV			0.72 kV			0.72 kV					
Rated insulation level	3 kV/1 min @ 50 Hz			3 kV/1 min @ 50 Hz			3 kV/1 min @ 50 Hz			3 kV/1 min @ 50 Hz					
Security factor	≤ 5			≤ 5			≤ 5			≤ 5					
Output specifications															
Secondary current	5 A 1 A			5 A 1 A			5 A 1 A			5 A 1 A					
General specifications															
Class	0.5 / 1 / 3			0.5 / 1 / 3			0.5 / 1 / 3			0.5 / 1 / 3 / 5P5					
Bus-bar size (mm) [diameter]	20 x 5 [23]			32 x 5 / 30 x 10 / 25 x 20 / 25 x 12 [24]			51 x 15 / 40 x 20 / 32 x 32 / 40 x 20 [41]			64 x 20 / 51 x 43 / [51]					
Standards	EN 61869-2, cURus, CSA			EN 61869-2, cURus, CSA			EN 61869-2, cURus, CSA			EN 61869-2, cURus, CSA					
Primary current															
	Burden (VA)			Burden (VA)			Burden (VA)			Burden (VA)					
	Class	0.5	1	3	Class	0.5	1	3	Class	0.5	1	3			
	50 A		1	1.25	40 A			1.25	50 A		1.75	150 A	2.5	5	
	60 A		1	1.25	50 A			1.5	60 A		2	200 A	3.25	6	
	70 A		1.5	1.75	60 A			2	70 A		2.25	250 A	2.5	4.5	
	75 A	1	1.25	1.75	70 A			2.5	75 A		3	300 A	3	4	
	80 A	1.25	1.5	2	75 A		1.75	2.5	80 A		3	400 A	6	9	
	100 A	1.5	1.75	2.25	80 A		2	2.75	100 A		2	3.5	500 A	10	12.5
	120 A	1.75	2	2.5	100 A		2.5	3	120 A		2.25	4	600 A	11	13.5
	125 A	2	2.25	2.75	120 A		2.75	3.75	125 A		2.5	4.5	700 A	12.5	15
	150 A	2.25	2.5	3	125 A	2	2.75	3.75	150 A	2.25	3	6	750 A	13	15.5
	160 A	2.5	2.75	3.25	150 A	3	4	5	160 A	2.5	3.5	6.5	800 A	14	16.5
	200 A	3	3.25	3.75	160 A	3	4	5	200 A	3	4.5	8.5	1000 A	17.5	20
	250 A	4.5	4.75	5.25	200 A	4	5	6.5	250 A	3.5	6.5	10.5	1200 A	20	22.5
	300 A	5	5.5	6	250 A	5.5	7	8	300 A	7	10	13	1250 A	20	22.5
					300 A	7	8.5	9.5	400 A	9	14	17	1500 A	27.5	30
					400 A	12	13.5	14.5	500 A	14	18	21	1600 A	27.5	30
					500 A	14	15.5	16.5	600 A	17	21	24			
					600 A	17.5	19	20	700 A	22	26	29			
									750 A	24	28	31			
									800 A	25	29	32			

Accuracy class depending on the burden of the secondary circuit

Current transformers

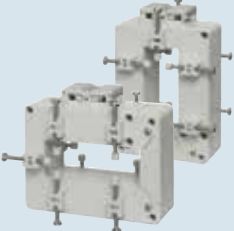
Current transformers

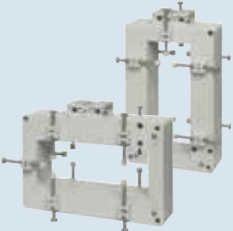
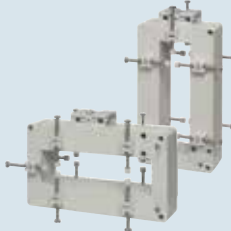
Types	CTD 8V CTD 8H	CTD 8Q	CTD 9V CTD 9H	CTD 10V CTD 10H
				
Dimensions HxWxD (mm)	133 x 87 x 40 104 x 117 x 40	144 x 129 x 40	178 x 92 x 40 109 x 162 x 40	178 x 107 x 40 124 x 162 x 40

Input specifications

	Current transformer 1-phase AC	Current transformer 1-phase AC	Current transformer 1-phase AC	Current transformer 1-phase AC
Operating frequency	50/60 Hz	50/60 Hz	50/60 Hz	50/60 Hz
Max. system voltage	0.72 kV	0.72 kV	0.72 kV	0.72 kV
Rated insulation level	3 kV/1 min @ 50 Hz	3 kV/1 min @ 50 Hz	3 kV / 1 min @ 50 Hz	3 kV / 1 min @ 50 Hz
Security factor	≤ 5	≤ 5	≤ 5	≤ 5

Output specifications

Secondary current	5 A 1 A	5 A 1 A	5 A 1 A	5 A 1 A
-------------------	------------	------------	------------	------------

General specifications

Class	0.5 / 1 / 3	0.5	0.5 / 1 / 3	0.5 / 1 / 3
Bus-bar size (mm) [diameter]	80 X 30	55 x 100	125 x 35	125 x 50
Standards	EN 61869-2, cURus, CSA	EN61869-2	EN 61869-2, cURus, CSA	EN 61869-2, cURus, CSA

Primary current

	Burden (VA)				Burden (VA)				Burden (VA)				Burden (VA)			
	Class	0.5	1	3	Class	0.5			Class	0.5	1	3	Class	0.50	1	3
Accuracy class depending on the burden of the secondary circuit	150 A			2	1000 A	15			400 A		3	6	400 A	1	7	10
	200 A			4	1500 A	15			500 A	2	4	8	500 A	3	10	14
	250 A			5	2000 A	15			600 A	4	6	10	600 A	5	12	17
	300 A		2	6	2500 A	15			700 A	4	8	10	700 A	8	15	20
	400 A	3	5	8	3000 A	15			750 A	4	8	10	750 A	10	15	20
	500 A	5	7	10	4000 A	15			800 A	4	8	10	800 A	10	15	20
	600 A	6	10	12					1000 A	6	10	13	1000 A	12	20	25
	700 A	6	10	12					1200 A	8	12	15	1200 A	15	25	30
	750 A	8	12	15					1250 A	8	12	15	1250 A	15	25	30
	800 A	8	12	15					1500 A	10	15	18	1500 A	20	30	40
	1000 A	10	15	20					1600 A	10	15	18	1600 A	20	30	40
	1200 A	12	15	20					2000 A	15	20	24	2000 A	25	40	50
	1250 A	12	15	20					2500 A	20	25	30	2500 A	30	50	60
	1500 A	15	20	25					3000 A	25	30	35	3000 A	30	50	60
	1600 A	15	20	25					3200 A	25	30	35	3200 A	30	50	60
	2000 A	20	25	30												
2500 A	25	30	40													

Current transformers

	Current transformers		Split core current transformers	
--	----------------------	--	---------------------------------	--

Types	CTD 11V CTD 11H	CTD 12V CTD 12H	CTD 5S	CTD 6S
-------	--------------------	--------------------	--------	--------



Dimensions HxWxD (mm)	178 x 98 x 40 115 x 160 x 40	178 x 125 x 40 140 x 157 x 40	94 x 83 x 40	114 x 107 x 40
-----------------------	---------------------------------	----------------------------------	--------------	----------------

Input specifications

	Current transformer 1-phase AC	Current transformer 1-phase AC	Split core current transformer 1-phase AC	Split core current transformer 1-phase AC
Operating frequency	50/60 Hz	50/60 Hz	50/60 Hz	50/60 Hz
Max. system voltage	0.72 kV	0.72 kV	0.72 kV	0.72 kV
Rated insulation level	3 kV/1 min @ 50 Hz	3 kV/1 min @ 50 Hz	3 kV/1 min @ 50 Hz	3 kV/1 min @ 50 Hz
Security factor	≤ 5	≤ 5	≤ 5	≤ 5

Output specifications

Secondary current	5 A 1 A	5 A 1 A	5 A 1 A	5 A 1 A
-------------------	------------	------------	------------	------------

General specifications

Class	0.5	0.5	1	1
Bus-bar size (mm)	125 x 37	125 x 53	27 x 32	52 x 51
Standards	EN 61869-2, cURus, CSA	EN 61869-2, cURus, CSA	EN 61869-2, cURus, CSA	EN 61869-2, cURus, CSA

Primary current

	Burden (VA)		Burden (VA)		Burden (VA)			Burden (VA)		
	Class	0.5	Class	0.5	Class	1	3	Class	1	3
	Accuracy class depending on the burden of the secondary circuit	1000 A	15	1000 A	15	100 A	1.5	1.5	150 A	1.5
	1500 A	15	1500 A	15	125 A	1.5	1.5	200 A	1.5	2
	2000 A	15	2000 A	15	150 A	1.5	2.5	250 A	1.5	3.75
	2500 A	15	2500 A	15	200 A	1.5	5	300 A	1.5	5
	3000 A	15	3000 A	15	250 A	1.5	5	400 A	2.5	5
	4000 A	15	4000 A	15	300 A	2.5	7.5	500 A	5	10
					400 A	5	10	600 A	7.5	15
								700 A	7.5	15
								750 A	7.5	15
								800 A	10	15
								1000 A	10	15

Current transformers

Split core current transformers

Active current sensor

Types

CTD 8S

CTD 9S

CTD 10S

ROG 400



Dimensions HxWxD (mm)	133 x 87 x 40	178 x 92 x 40	178 x 107 x 40	54 x 29 x 17
-----------------------	---------------	---------------	----------------	--------------

Input specifications

	Split core current transformer 1-phase AC	Split core current transformer 1-phase AC	Split core current transformer 1-phase AC	Split core AC current sensor 1-phase AC
Operating frequency	50/60 Hz	50/60 Hz	50/60 Hz	45 to 65 Hz
Max. system voltage	0.72 kV	0.72 kV	0.72 kV	
Rated insulation level	3 kV/1 min @ 50 Hz	3 kV/1 min @ 50 Hz	3 kV/1 min @ 50 Hz	3 kV/1 min @ 50 Hz
Security factor	≤ 5	≤ 5	≤ 5	

Output specifications

Secondary current	5 A 1 A	5 A 1 A	5 A 1 A	4 to 20 mA DC
-------------------	------------	------------	------------	---------------

General specifications

Class	1	1	1	
Bus-bar size (mm)	81 x 31	125 x 35	125 x 50	[40]
Standards	EN 61869-2, cURus, CSA	EN 61869-2, cURus, CSA	EN 61869-2, cURus, CSA	

Primary current





	Burden (VA)			Burden (VA)			Burden (VA)		
	Class	1	3	Class	1	3	Class	1	3
150 A			1.5	400 A		3	400 A	1	7
200 A			1.5	500 A	2	4	500 A	3	10
250 A			2	600 A	4	6	600 A	5	12
300 A			2	700 A	4	8	700 A	8	15
400 A	3	5		750 A	4	8	750 A	10	15
500 A	5	7		800 A	4	8	800 A	10	15
600 A	6	10		1000 A	6	10	1000 A	12	20
700 A	6	10		1200 A	8	12	1200 A	15	25
750 A	8	12		1250 A	8	12	1250 A	15	25
800 A	8	12		1500 A	10	15	1500 A	20	30
1000 A	10	15		1600 A	10	15	1600 A	20	30
1200 A	12	15		2000 A	15	20	2000 A	25	40
1250 A	12	15		2500 A	20	25	2500 A	30	50
1500 A	15	20		3000 A	25	30	3000 A	30	50
1600 A	15	20		3200 A	25	30	3200 A	30	50
2000 A	20	25							
2500 A	25	30							



Accuracy class depending on the burden of the secondary circuit

400 AAC

Current transformers

Split core and Rogowski current sensors for EM210_MV

Types	CTV-1X	CTV-2X	CTV-3X	CTV-4X
				
Input / output specifications				
Primary current 50/60 Hz	60 A	100 A	200 A	200 or 400 A
Secondary output	333 mV	333 mV	333 mV	333 mV
General specifications				
Accuracy	1%	1%	1%	1%
Linearity	0.5%	0.5%	0.5%	0.5%
Phase error at nominal current	≤4°	≤2°	≤2°	≤2°
Max. system voltage	660 V	660 V	660 V	660 V
Opening angle	180°	180°	180°	180°
Certifications	CE - cURus	CE - cURus	CE - cURus	CE - cURus
References				
	CTV1X60A333MV	CTV2X100A333MV	CTV3X200A333MX	CTV4X200A333MV CTV4X400A333MV

Types	CTV-6X	CTV-8X	ROG4X
			
Input / output specifications			
Primary current 50/60 Hz	400 A	800 A	4000 A
Secondary output	333 mV	333 mV	
General specifications			
Accuracy	1%	1%	1%
Linearity	0.5%		
Phase error at nominal current	≤2°	≤2°	
Max. system voltage	660 V	660 V	600 V (cat III)
Opening angle	180°		
Coil length			250, 350, 600 or 900
Certifications	CE - cURus	CE - cURus	CE - cURus
References			
	CTV6X400A333MV	CTV8X800A333MV	ROG4X1002M2503X ROG4X1002M3503X ROG4X1002M6003X ROG4X1002M9003X

Current transformers

Split core current transformers

Types

CTA-5X



CTA-6X



Input/Output specifications

Primary current 50/60 Hz	100 to 300 A	200 to 600 A
Secondary output	5 A	5 A

General specifications

Accuracy	cl. 1 or 3	cl. 1 or 3
Max. rated system voltage	600 V	600 V
Rated insulation level	0.72 kV AC, dielectric strength 3 kV AC for 1 min	0.72 kV AC, dielectric strength 3 kV AC for 1 min
Insulation class	B	B
Opening angle	180°	180°
Certifications	CE - cURus	CE - cURus





References

CTA5XxxxA5A

CTA6XxxxA5A

Current transformers

Current transformers for monitoring relays

Types	MI	MP	A 82	E 83
				
Dimensions HxWxD (mm)	45 x 52 x 16 [5 / 20] 67.5 x 95 x 20 [100 / 500]	45 x 120 x 16 [5 / 20] 114 x 150 x 23 [100 / 500]	67.5 x 95 x 20	56 x 22.5 x 49
Function	1-phase AC. Output voltage. Cable hole.	3-phase AC. Output voltage. Cable hole.	1-phase AC. Output 0 / 4-20 mA DC, 0-10 VDC (A82-30). Cable hole. Led indication.	1-phase AC. Output 4-20 mA DC. Cable hole. DIN-rail mounting.

Input specifications

Input current	0.5 - 5 AAC [5] 2 - 20 AAC [20] 10 - 100 AAC [100] 50 - 500 AAC [500]	0.5 - 5 AAC [5] 2 - 20 AAC [20] 10 - 100 AAC [100] 50 - 500 AAC [500]	0 - 25 AAC [25] 0 - 50 AAC [50] 0 - 100 AAC [100] 0 - 250 AAC [250] 0 - 500 AAC [500]	0 - 5 AAC 0 - 10 AAC 0 - 15 AAC 0 - 20 AAC 0 - 25 AAC 0 - 30 AAC 0 - 50 AAC
Max. continuous current	20 AAC [5] 50 AAC [20] 250 AAC [100] 750 AAC [500]	20 AAC [5] 50 AAC [20] 250 AAC [100] 750 AAC [500]	600 AAC	100 AAC
Dielectric voltage	6 kV ACrms	6 kV ACrms	6 kV ACrms	

Output specifications

Output value	0.4 - 4 V _p The output voltage is proportional to the input current	0.4 - 4 V _p The output voltage is proportional to the highest current value in the 3 conductors which are drawn through the holes of the current metering transformer	A82 - 10: 0-20 mA DC A82 - 20: 4-20 mA DC A82 - 30: 0-10 VDC The output current (A82-10, A82-20) and voltage (A82-30) are proportional to the input current	4 - 20 mA DC The output current is proportional to the input current
Output tolerance	± 5% @ I _n	± 5% @ I _n	± 2% @ 50 Hz	± 2% @ 50 Hz
Rated insulation voltage (cable)	250 VACrms	250 VACrms	250 VACrms	

General specifications

Cable hole diameter	10.5 mm [5 / 20] 27 mm [100 / 500]	3 x 12 mm [5 / 20] 3 x 27 mm [100 / 500]	27 mm	12 mm
Connection cable	2 m PVC 2 x 0.5 mm ²	2 m PVC 2 x 0.5 mm ²	A82-10, A82-30: 2 m, 3x0.25 m ² A82-20: 2 m, 2x0.25 m ²	Screw terminal 2 x 1.5 mm ²
Operating temperature	-20°C to +60°C	-20°C to +60°C	-20°C to +50°C	-20°C to +50°C

References

	MI 5	MP 3005	A 82-XX 25	E 83-20 50
	MI 20	MP 3020	A 82-XX 50	
	MI 100	MP 3100	A 82-XX 100	
	MI 500	MP 3500	A 82-XX 250	
			A 82-XX 500	
			XX = 10: 0-20 mA DC = 20: 4-20 mA DC = 30: 0-10 VDC	

Current transformers

Core balance transformers

Types

CTG



Dimensions HxWxD (mm)

Hole Ø 35, 50, 70, 120, 160 or 210 mm

Function

Zero current transformer for DEA71 and DEB71

Input specifications

Input type	1-phase 3-phase 3-phase + N
Max. Input voltage	750 VAC
Operating frequency	50 Hz - 60 Hz
Dielectric voltage	3 kV ACrms

Output specifications

Reduction ratio	1:1000
Output type	Bi-polar
Output terminals	Screw connector



General specifications

Cable hole diameter	From 35 mm to 210 mm
Connection	2.5 mm ²
Operating temperature	-5°C to +55°C

References

CTG035
CTG050
CTG070
CTG120
CTG160
CTG210

Data aggregation solutions



	Web-server	Web-server
Types	UWP 3.0	VMU-C EM
		
Dimensions HxWxD (mm)	2-DIN module	2-DIN module
Description	Web-Server, gateway and controller for energy efficiency management and building automation; compatible with Carlo Gavazzi meters, analyzers and building automation solutions, it provides easy integration with local or remote BMS/EMS/Server solutions and a configurable Web interface for analysis, alerting and reporting	Web-server for datacenter applications which controls and supervises any electrical installation acquiring information from energy meters, power analyzers and VMU I/O modules. It provides information via Internet, so data is available anywhere
Type	Micro PC	Micro PC
Storage memory	4 GB	4 GB
Back-up memory	Micro-SD / Micro-SDHC / USB	Micro-SD / Micro-SDHC / USB
LED		
Status and colour	One LED with different colours for BUS communication, communication ports, status and power supply	One LED with different colours for internal BUS communication, communication ports, alarms and power supply
Communication port and Output specifications		
RS485	2 ports for power analyzers, energy meters and Modbus devices	1 port for VMU I/O modules, 1 port for power analyzers, energy meters and Modbus devices
Ethernet	1 port for Internet / LAN connection, BACnet clients and Modbus/TCP devices	1 port for Internet / LAN connection and Modbus/TCP devices
USB	1 USB "mini-A" (service port)	1 USB "A" (for USB stick) and 1 USB "mini-A" (service port)
Connections		
RS485	3 screw terminals per port	3 screw terminals per port
Ethernet	RJ-45 connector (10 / 100 Base-T)	RJ-45 connector (10 / 100 Base-T)
USB	High Speed USB 2.0	High Speed USB 2.0
General specifications		
Voltage supply	From 12 to 28 VDC	From 12 to 28 VDC
Power consumption	≤ 5 W	≤ 5 W
Approvals/Marks	CE - cULus listed - BTL/BACnet	CE - cULus listed

Data aggregation solutions



	USB dongle connection module	Wireless endpoint gateway	Wireless master gateway
Types	VMU-D	UWP-A	UWP-M
			
Dimensions HxWxD (mm)	2-DIN module	2-DIN module	2-DIN module
Description	Accessory module for connecting third party USB dongle modems (3G or 4G) approved by Carlo Gavazzi to VMU-C systems	RS485 to long range wireless, LoRaWAN® adapter converting a CG meter or power analyzer into a wireless endpoint	Long range wireless concentrator to connect multiple UWP A endpoints to the UWP 3.0 controller
Type	USB dongle connection module	Gateway	Gateway
Remote communication specifications			
SIM card	Mobile, SIM Card	Long range wireless, LoRaWAN® (EU868 and US915 Bands, Europe and North America)	Long range wireless (868 MHz, Europe only)
Compatibility	Compatible with USB modems (3G or 4G) approved by Carlo Gavazzi	CG Meters and analyzers	UWP 3.0
Supported services	Internet communication; SMS		
LED			
Status and colour	Single colour green for power supply status	Power ON, bus communication, diagnostics	Power ON, bus communication, diagnostics
Communication port and Output specifications			
RS485		1 port for one power analyzer or energy meter	
USB	1 USB "A" (for USB dongle modem connection)	1 USB for Set-up via UCS software	
Antenna			
Connector	Depending on the modem unit	SMA	SMA
Type	Depending on the modem unit	High performance antenna 868 MHz	High performance antenna 868 MHz
Connections			
RS485		3 screw terminals per port	
Ethernet			
USB		High Speed USB 3.0/2.0	
General specifications			
Voltage supply	From 12 to 28 VDC	24 VDC, 115-240 VAC	24 VDC, 115-240 VAC
Power consumption	IN/OUT connection to supply also the VMU-C unit; consumption depending on the connected optional modules (range: from 8.6 W to 18.6 W)		1.3 W max
Approvals/Marks	CE - cULus listed	CE - LoRaWAN®	CE

Data aggregation solutions





VMU I/O optional modules for VMU-C EM

Types	VMU-M EM	VMU-P EM	VMU-O EM
			
Dimensions	1-DIN module	1-DIN module	1-DIN module
Description	Master unit 6-dgt readout	Environment variable measurement unit	Inputs / outputs unit
Function	VMU-M performs the local bus management of VMU-P both measuring units and VMU-O I/O unit	2 temperatures, 1 analogue and 1 pulse rate output	VMU-O allows to add for every single unit available in the local bus two digital inputs and two relay outputs
Input specifications			
Range code	2 Pt100 or Pt1000, 3-wires (-50.0 to +200.0°C) or one digital input and one pulse input, for local management	2 Pt100 or Pt1000, 3-wires 1 analogue input (20 mA or 120 mV). 1 pulse rate input (0 to 1000 Hz max.) [2TIW]	2 digital inputs for Protection trip detection or others
Accuracy	±(0.5%RDG + 5dgt)	±(0.2%RDG + 1dgt)	
Output specifications			
Alarm	Real and virtual alarm management of all variables coming from VMU-M and VMU-P with local event logging		2 digital outputs for alarm notification as local alarms or as a digital input status change. SPST relay type
Serial communication	Local bus: up to 1 VMU-P and 3 VMU-O units RS485 communication port (Modbus)	Local bus: one VMU-P unit per bus	Local bus: up to 3 VMU-O units
Others		Front multicolour LED to show the status of the unit	Front multicolour LED to show the status of the unit
General specifications			
Power supply	12 to 28 VDC power supply	Self-power supply from VMU-M unit	Self-power supply from VMU-M unit
Approvals/Marks	cULus approved	cULus approved	cULus approved



Data aggregation solutions

	Pulse counters concentrators		Aggregation server
Types	VMU-MC	VMU-OC	Em ² -Server
			
Dimensions	1-DIN module	1-DIN module	
Description	Pulse counter concentrator	Pulse input extender	Em ² -Server is a Cloud/On-Premise EMS solution capable of aggregating information from up to 100 installations powered by UWP 3.0 or VMU-C EM units. Data from the plants is transmitted through Internet, stored inside the embedded database and presented by the integrated web interface. Em ² -Server + UWP 3.0 or VMU-C EM is a solid, reliable and plug'n'play architecture aimed at managing multiple sites projects
Function	VMU-MC concentrates 2 pulse counter inputs (up to 11 with optional VMU-OC extender), and makes the relevant totalizers available via Modbus/RTU	3 additional SO pulse counter inputs	Multi-user, Multi-Language. Energy data aggregation. Database storage. Present and Historical data analytics. PDF and Excel Reports. Set-up and operation via Web Interface
Type			Virtual Machine Software
Input specifications			
Range code	2 SO inputs (either pulse for pulse counting or ON/OFF status monitoring)	3 SO inputs (either pulse for pulse counting or ON/OFF status monitoring)	
Pulse frequency	Max 100 Hz	Max 100 Hz	
Output specifications			
Serial communication	Local bus: up to 3 VMU-OC units RS485 communication port (Modbus)	Local bus: up to 3 VMU-OC units	
Others	LCD for Status, totalizers, active tariff display Front multicolor LED for power, MODBUS communication, local bus alert	Front multicolour LED to show the status of the unit	
Compatibility			
Host operating system			Operating system compatible with VMWARE 64 bit technology
Virtual Machine compatibility			VMWARE 64 bit
Hardware compatibility			64 bit architecture compatible with VMWARE 64 bit
Cloud compatibility			Hosting providers compatible with VMWARE technology
Software/Firmware specification			
Data acquisition			By means of Carlo Gavazzi's DP (Data push) protocol
Integrated operating system			64 bit Linux
Integrated data base			Industrial class SQL relational database
User interface			Integrated multi-user, multilingual web interface
General specifications			
Power supply	15 to 24 VDC power supply	Self-power supply from VMU-MC unit	
Approvals/Marks	cULus approved	cULus approved	
Managed UWP 3.0 or VMU-C EM units			From 20 to 100
Software installation			By DVD or USB stick containing the Em ² -Server Virtual machine
Licensing			Perpetual license based on connected UWP 3.0 or VMU-C EM units

Data aggregation solutions





	Serial converter	Ethernet gateway	M-Bus and wireless M-Bus to MODBUS/TCP gateways	M-bus converter	Optical communication interface
Types	SIU-PC3	SIU-TCP	SIU-MBM	VMU-B	OPTOPROG
					
Dimensions HxWxD (mm)	Front: 60 x 37.5	Front: 78 x 65	Front: 95 x 71	Front: 90 x 17.5	52 x 17.5 x 50.8
Function	RS422 / RS485 to USB converter	[SIU TCP2] RS232 / 485 to Ethernet Gateway [SIU TCP3] RS232 / 485 to Ethernet Modbus Gateway	Wireless M-Bus [only SIU-MBM-02] and M-Bus to Modbus/TCP gateway	Modbus to M-bus converter	Bluetooth and USB interface for meters and analysers with optical port
Port 1					
Port connections	USB type A	Ethernet, 10 / 100 Mbps RJ45	Ethernet, 10 / 100 Mbps RJ45	RS485	Bluetooth, Micro-USB
Baud rate	Max 961.6 kBaud	Max 230400 Baud			
Port 2					
Port connections	RS232, RS485 2-wire communication	[SIU TCP2] RS232, RS485 2-wire and 4-wire communication [SIU TCP3] RS232, RS485 2-wire communication	M-Bus, [SIU-MBM-02] wireless M-Bus (EU868MHz)	M-bus	Optical
General specifications					
Power supply	Self supplied by USB port	9 to 30 VDC AD5V1A: AC / DC power supply adapter (on request)	15 to 21 VAC; 18 to 35 VDC	18 to 260 VAC/DC	Battery
Approvals/Marks	CE - FCC	CE	CE	CE	CE - FCC - IC - Bluetooth 4.0
References					
	SIU PC3	SIU TCP2	SIU-MBM-01 SIU-MBM-01-160 (M-Bus)	VMUBM2US1B1A (for EM210, EM26)	OPTOPROG
		SIU TCP3	SIU-MBM-02 (M-Bus and wireless M-Bus)	VMUBM2US1B1B (for EM27x, EM280)	
				VMUBM2US1B1C (for WM15)	

PV monitoring solutions

	Web-server	USB dongle connection module
Types	VMU-C PV	VMU-D
		
Dimensions HxWxD (mm)	2-DIN module	2-DIN module
Description	VMU-C is a Web-server which controls and supervises a photovoltaic installation acquiring information from Eos-Array groups, inverters and energy meters. The VMU-C provides information via Internet so data is available wherever you are. VMU-C is also capable of M2M communication by scheduling FTP uploads or by interacting with its HTTP API	Accessory module for connecting third party USB dongle modems (3G or 4G) approved by Carlo Gavazzi to VMU-C systems
Type	Micro PC	USB dongle connection module
Storage memory	4 GB	
Back-up memory	Micro-SD / Micro-SDHC / USB	
Mobile communication specifications		
SIM card		Depending on the modem unit
Compatibility		Compatible with USB modems (3G or 4G) approved by Carlo Gavazzi
Supported services		Internet communication; SMS
LED		
Status and colour	One led with different colors for internal BUS communication, communication ports, alarms and power supply	Single colour green for power supply status
Communication port and output specifications		
RS485	1 port for Eos-Arrays, 1 port for inverters and energy meters	
Ethernet	1 port for Internet / LAN connection	
USB	1 USB "A" (for USB stick) and 1 USB "mini-A" (service port)	1 USB "A" (for USB dongle modem connection)
Antenna		
Connector		Depending on the modem unit
Type		Depending on the modem unit
Connections		
RS485	3 screw terminals per port	
Ethernet	RJ-45 connector (10 / 100 Base-T)	
USB	High Speed USB 2.0	
General specifications		
Voltage supply	From 12 to 28 VDC	From 12 to 28 VDC
Power consumption	≤ 5 W	IN/OUT connection to supply also the VMU-C unit; consumption depending on the connected optional modules (range: 8.6 W to 18.6 W)
Approvals/Marks	CE - cULus listed	CE - cULus listed

PV monitoring solutions

EOS-Array solar control solution

Types	VMU-M	VMU-S	VMU-P	VMU-O
				
Dimensions HxWxD (mm)	1-DIN module	1-DIN module	1-DIN module	1-DIN module
Description	Master unit 6-dgt readout	String unit, with built-in protection fuseholder	Environment variable measurement unit	Inputs/outputs unit
Function	VMU-M performs the local bus management of VMU-S, VMU-P both measuring units and VMU-O I/O unit	Variables measuring unit, DC current, voltage, power and energy metering. String control and efficiency measurement	PV module temperature, air temperature, sun irradiance and wind speed metering	VMU-O allows to add for every single unit available in the local bus two digital inputs and two relay outputs

Input specifications

Range code	2 Pt100 or Pt1000, 3-wire (-50.0°C to +200.0°C) or one digital input and one pulse input. [T2]	Direct connections 16 A / 1000 VDC [AV10]. Measurements: V, A, W, Wh	2 Pt100 or Pt1000, 3-wire (PV and air temperature). 1 irradiance input (up to 120 mV [2TIW] or 4-20 mA [2TCW]). 1 wind speed input (0 to 1000 Hz max.)	2 digital inputs for "Protection trip detection or others" [I2]
Accuracy	±(0.5% RDG + 5dgt)	±(0.5% RDG + 2dgt)	±(0.2% RDG + 1dgt)	

Output specifications



Alarm	Real and virtual alarm management of all variables coming from VMU-M, VMU-S, and VMU-P with event logging			2 digital outputs for alarm notification as string alarm or as a digital input status change. SPST relay type. [R2]
Serial communication	Local bus: up to 15 mixed VMU-S, VMU-P and VMU-O units RS485 communication port (Modbus) [S1]	Local bus: up to 15 VMU-S units in the same bus [S]	Local bus: one VMU-P unit per bus [S]	Local bus: up to 7 VMU-O units
Others	Data logger (V, A, W, PV cell and air temperature, irradiation, wind speed) DC/AC efficiency	Diagnostics functions: antitheft control, fuse blow detection, wrong PV panel connection. Front multicolour LED to show the status of the unit	Front multicolour LED to show the status of the unit	Front multicolour LED to show the status of the unit

General specifications



Power supply	12 to 28 VDC power supply [A]	Self-power supply from VMU-M unit [X]	Self-power supply from VMU-M unit [X]	Self-power supply from VMU-M unit [X]
Approvals/Marks	CE - cULus listed	CE - cULus listed	CE - cULus listed	CE - cULus listed

PV monitoring solutions

EOS-Array Lite solar control solution

Types	VMU-ML	VMU-S0	VMU-P
			
Dimensions HxWxD (mm)	1-DIN module	1-DIN module	1-DIN module
Description	Master unit 6-dgt readout	String unit, with built-in protection fuseholder	Environment variable measurement unit
Function	VMU-ML performs the local bus management of VMU-S0, VMU-P both measuring units and VMU-O output unit	Variables measuring unit, DC current and voltage	PV module temperature, air temperature, sun irradiance
Input specifications			
Range code		Direct connections 16 A / 1000 VDC [AV10]. Measurements: V, A	1 Pt100 or Pt1000, 3-wire (PV and air temperature). 1 irradiation input (up to 120 mV [1TI] or 4 - 20 mA [2TCW])
Accuracy		±(0.5%RDG + 2dgt)	±(0.2%RDG + 1dgt)
Output specifications			
Alarm	Single real or virtual alarm management of all variables coming from VMU-ML, VMU-S0, and VMU-P		
Serial communication	Local bus: up to 15 mixed VMU-S0, VMU-P and VMU-O units RS485 communication port (Modbus) [S1]	Local bus: up to 15 VMU-S0 units in the same bus [S]	Local bus: one VMU-P unit per bus [S]
Others	Front dual colour LED to show the status of the unit	Diagnostics functions: wrong PV panel connection	Front multicolor LED to show the status of the unit
General specifications			
Power supply	12 to 28 VDC power supply [A]	Self-power supply from VMU-ML unit [X]	Self-power supply from VMU-ML unit [X]
Approvals/Marks	CE - cULus listed	CE - cULus listed	CE - cULus listed

PV monitoring solutions

	Solar irradiance sensor		Pyranometer
Types	PVS-1V	PVS-1A	PVS-2A
			

Dimensions (mm)	57 x 48 x 15 (not including clamp)	62 x 48 x 15 (not including clamp)	162 x 215 x 40
Description	Solar irradiance sensor based on photovoltaic technology built with a solid aluminium case and anti-UV encapsulating resin	Solar irradiance sensor based on photovoltaic technology built with a solid aluminium case and anti-UV encapsulating resin	Global solar radiation sensor based on a thermopile transducer compliant with WMO (World Meteorological Organization) standards for environmental monitoring, provided with worldwide valid calibration certificate



Environmental specifications

Operating temperature	-10°C to 80°C	-10°C to 80°C	-40°C to 80°C
Degree of protection	IP67	IP67	IP67



General specifications

Technology	Crystalline calibrated cell	Crystalline calibrated cell	2 nd Class Thermopile Pyranometer according to ISO9060
Output	80 mV @ 1000 W/m ² STC	4-20 mA	4-20 mA
Calibration	According to IEC 60904-2 and 60904-4 (calibration certificate as option)	According to IEC 60904-2 and 60904-4 (calibration certificate as option)	According to ISO9847 (calibration certificate included)
Solar irradiance range	0-1250 W/m ²	0-1250 W/m ²	0-2000 W/m ²
Connector	3 PIN Phoenix M8 IP67 connector (male and female included)	3 PIN Phoenix M8 IP67 connector (male and female included)	7 pin IP68 connector (male, female and 10 meters cable included)
Housing material	Aluminium	Aluminium	Aluminium
Power supply	Self-powered	Powered by VMU-P module through the 4-20 mA current loop	10-28 VDC, power consumption < 0.1 W
Approvals/Marks	CE	CE	CE



Building automation

	Automation server		Controllers	
Function	Building		Building	Hotel/Home
				
Dimensions HxWxD (mm)	2-DIN module		2-DIN module	2-DIN module
Description	<p>It is an automation server, a powerful IIoT gateway and a programmable unit for building automation functions. It is enhanced by a configurable web interface which makes it an outstanding interface. It integrates the standard IEC 61131 PLC (Codesys), so that any building automation function can be programmed by means of a standard and well-known tool</p>		<p>Web-Server, gateway and controller for energy efficiency management and building automation; compatible with Carlo Gavazzi meters, analyzers and building automation solutions, it provides easy integration with local or remote BMS/EMS/Server solutions and a configurable Web interface for analysis, alerting and reporting</p>	<p>Room controller for hotel and home application. Programmable light functions to control DALI lamps</p>
Type	Micro PC		Micro PC	Micro PC
Storage memory	4 GB		4 GB	4 GB
Back-up memory	SD / Micro-SD / Micro-SDHC / USB		Micro-SD / Micro-SDHC / USB	Micro-SD / Micro-SDHC / USB
LED				
Status and colour			One LED with different colours for BUS communication, communication ports, status and power supply	One LED with different colours for internal BUS communication, communication ports, alarms and power supply
Communication port and output specifications				
RS485	1 port for power analyzers, energy meters and Modbus devices		2 ports for power analyzers, energy meters and Modbus devices	
Ethernet	2 ports for Internet / LAN connection, IIoT, BACnet, Modbus, KNX IP		1 port for Internet / LAN connection, BACnet clients and Modbus/TCP devices	1 port for Internet / LAN connection and Modbus/TCP devices
USB	1 USB "A" (for USB stick)		1 USB "A" (for USB stick) and 1 USB "mini-A" (service port)	1 USB "A" (for USB stick) and 1 USB "mini-A" (service port)
Connections				
RS485	3 screw terminals per port		3 screw terminals per port	
Ethernet	RJ-45 connector (10 / 100 Base-T)		RJ-45 connector (10 / 100 Base-T)	RJ-45 connector (10 / 100 Base-T)
USB	High Speed USB 2.0		High Speed USB 2.0	High Speed USB 2.0
General specifications				
Voltage supply	From 10 to 32 VDC		From 12 to 28 VDC	From 12 to 28 VDC
Power consumption	≤ 9 W		≤ 5 W	≤ 5 W
Approvals/Marks	CE - cULus listed		CE - cULus listed - BTL/BACnet	CE - cULus listed
References				
	XAP10RSEXX		UWP30RSEXX	SA2WEB24





Building automation

Bus generators			
Function	Wired	Wired	Wireless
			
Dimensions (mm)	2-DIN module	2-DIN module	2-DIN module
Functions	Smart Dupline® generator	Dupline® generator	Wireless base unit for generating wireless network
Electrical specifications			
Power supply	24 VDC ± 20%	24 VDC ± 20%	24 VDC, 115-240 VAC
General specifications			
LEDs	Green, yellow	Green, yellow	Green, yellow, blue
Mounting	DIN-rail (2 modules)	DIN-rail (2 modules)	DIN-rail (2 modules)
Degree of protection	Front: IP40, Screw terminal: IP20	Front: IP40, Screw terminal: IP20	Front: IP40, Screw terminal: IP20
Pollution degree	2 (IEC 60664-1, par. 4.6.2)	2 (IEC 60664-1, par. 4.6.2)	2 (IEC 60664-1, par. 4.6.2)
Operating temperature	-20°C to +50°C	-20°C to +50°C	-20°C to +50°C
Storage temperature	-50°C to +85°C	-50°C to +85°C	-50°C to +85°C
Humidity (non condensing)	20 to 80 %	20 to 80 %	20 to 80 %
Main features	Smart Dupline® bus generator. Connection of up to 250 slave modules	Dupline® bus generator	Wireless bus generator. Connection of up to 250 slave modules. Based on IEEE 802.15.4, @ 2.4 GHz Range up to 700 m
References			
	SH2MCG24	SH2DUG24	SH2WBU230N

Building automation

		DALI		USB dongle
Function	Master	Ballast	Connection module	
				
Dimensions (mm)	2-DIN module	210 x 50 x 32	2-DIN module	
Functions	DALI Master and DALI Power supply	DALI driver for DT6 and DT8 LEDs	Remote access by Internet when a wired connection is not available Plug'n'play configuration SMS alerting SMS commands Email alerting	
Electrical specifications				
Power supply	230 VAC	230 VAC	12 to 28 VDC	
General specifications				
LEDs	Green, yellow, yellow		Green	
Mounting	DIN-rail (2 modules)		DIN-rail (2 modules)	
Degree of protection	Front: IP40, Screw terminal: IP20	IP20	Front: IP40, Screw terminal: IP20	
Pollution degree	2 (IEC 60664-1, par. 4.6.2)	2 (IEC 60664-1, par. 4.6.2)		
Operating temperature	-20°C to +50°C	-20°C to +45°C	-25°C to +65°C	
Storage temperature	-40°C to +70°C	-40°C to +80°C	-30°C to +70°C	
Humidity (non condensing)	20 to 80 %	10 to 95 %		
Main features	Acts as a gateway between Smart Dupline® and DALI. Enables the use of DALI lighting actuators in the system - Tunable white management	DALI approved driver for standard and tunable white LEDs. It controls warm white and cool white output via a single DALI address, providing high power factor and efficiency. The output current is programmed by means of dip-switches, while the address can be assigned either by a DALI master or manually by means of the push-button	Compatible with UWP 3.0 controller Mobile Internet connection Compatible with USB dongle modems. Watchdog features to prevent common mobile network hassles	
References				
	SB2DALIT8230	SBBADT8CCT	SH2DSP24	

Building automation

	Network module		Relay modules	
Function	Wireless repeater	Wired repeater	SPST relay	Bistable relay
				
Dimensions (mm)	2-DIN module	2-DIN module	2-DIN module	2-DIN module
Functions	Wireless repeater for wireless I/O modules Simplifies the network design	Repeater and isolator	Four-relay output module	Four-relay output module
Electrical specifications				
Outputs			4	4
Power supply	24 VDC - 115-240 VAC	230 VAC	24 VDC	Bus
General specifications				
LEDs	Green, blue	Green, yellow, yellow	Green, yellow, red	Green, yellow, red
Mounting	DIN-rail (2 modules)	DIN-rail (2 modules)	DIN-rail (2 modules)	DIN-rail (2 modules)
Degree of protection	Front: IP40, Screw terminal: IP20	Front: IP40, Screw terminal: IP20	Front: IP40, Screw terminal: IP20	Front: IP40, Screw terminal: IP20
Pollution degree	2 (IEC 60664-1, par. 4.6.2)	2 (IEC 60664-1, par. 4.6.2)	2 (IEC 60664-1, par. 4.6.2)	2 (IEC 60664-1, par. 4.6.2)
Operating temperature	0°C to +50°C	0°C to +50°C	-20°C to +50°C	-20°C to +50°C
Storage temperature	-50°C to +85°C	-50°C to +85°C	-50°C to +85°C	-50°C to +85°C
Humidity (non condensing)	20 to 90 %	20 to 90 %	20 to 80 %	20 to 80 %
Main features	Extends the network length to cover distances longer than 700 m line of sight. Up to four repeaters can be programmed between SH2WBU230N base and the wireless I/O modules	Extends the transmission distance by regenerating the carrier signal and providing 300 mA bus output. Acts as an isolator between primary and secondary Dupline®	Load: 5 A, voltage free x 4 Local bus	Load: 16 A, 230 VAC x 4 Local bus
References				
	SBP2WREP230	SB2REP230	SH2RE1A424	SH2RE16A4

Building automation

Relay modules

Output type

Bistable relay

Bistable relay

Wireless relay



Dimensions (mm)

2-DIN module

26 x 39 x 17

40 x 45 x 31

Functions

Two-relay output module with energy measurement

Small sized remote relay output

Wireless relay output module with energy measurement

Electrical specifications

Outputs

2

1

1

Power supply

230 VAC

Bus

230/110 VAC

General specifications

LEDs

Green, yellow, red

Green, blue

Mounting

DIN-rail (2 modules)

Decentralized

Degree of protection

Front: IP40,
Screw terminal: IP20

Pollution degree

2 (IEC 60664-1, par. 4.6.2)

3 (IEC 60664)

2 (IEC 60664-1, par. 4.6.2)

Operating temperature

-20°C to +50°C

-20°C to +50°C

-20°C to +50°C

Storage temperature

-50°C to +85°C

-50°C to +85°C

-50°C to +85°C

Humidity (non condensing)

20 to 80 %

20 to 80 %

20 to 80 %

Main features

Load: 16 A, 230 VAC x 2
Energy reading,
Local bus

Load: 13 A, 250 VAC

Load: 10 A, 250 VAC
Energy reading,
Wireless

References

SH2RE16A2E230

BDA-RE13A-U

230 VAC

SHJWRE10AE230

115 VAC



SHJWRE10AE115

Capacitive push buttons

SHJWRE10AeLS230

Building automation

Roller blind modules

Output type	SPST relay	SPST relay	SPST relay
			

Dimensions (mm)	50 x 50 x 30	2-DIN module	2-DIN module
Functions	Decentralized module for up/down control of one rollerblind motor	Relay output module for up/down control of two AC rollerblind motors	Relay output module for up/down control of two DC rollerblind motors

Electrical specifications

Outputs	1 SPST relay & 1 SPDT relay	2 SPST + 2 SPDT relay	2 SPST + 2 SPDT relay
Inputs	AC	AC	DC
Power supply	230 VAC ± 15%	24 VDC ± 20%	24 VDC ± 20%





General specifications

LEDs		Green, yellow, red	Green, yellow, red
Mounting	Eurobox	DIN-rail (2 modules)	DIN-rail (2 modules)
Degree of protection		Front: IP40, Screw terminal: IP20	Front: IP40, Screw terminal: IP20
Pollution degree	3 (IEC 60664)	2 (IEC 60664-1, par. 4.6.2)	2 (IEC 60664-1, par. 4.6.2)
Operating temperature	-20°C to +50°C	-20°C to +50°C	-20°C to +50°C
Storage temperature	-50°C to +85°C	-50°C to +85°C	-50°C to +85°C
Humidity (non condensing)	20 to 80 %	20 to 80 %	20 to 80 %
Main features	Up/down control, tilting, local bus	Up/down control, tilting, local bus	Up/down control, tilting, local bus





References

	SHDRODC230	SH2ROAC224	SH2RODC224
--	-------------------	-------------------	-------------------

Building automation

		Dimmer modules		Output modules
Output type	Power mosfet	Wireless dimmer	1 to 10 V output	Solid state relay
				
Dimensions (mm)	2-DIN module	40 x 45 x 31	2-DIN module	2-DIN module
Functions	Power dimmer up to 500 W for R, L, C load and LED lamps	Power dimmer up to 200 W for R, L, C load and LED lamps	Analogue output dimmer for adjustable ballast with 1 to 10 V input	Four-solid-state relay output module
Electrical specifications				
Outputs	1	1	4	4
Power supply	230 VAC	230/110 VAC	24 VDC ± 20%	24 VDC ± 20%
General specifications				
LEDs	Green, yellow, red	Green, blue	Green, yellow, red	Green, yellow, red
Mounting	DIN-rail (2 modules)		DIN-rail (2 modules)	DIN-rail (2 modules)
Degree of protection	Front: IP40, Screw terminal: IP20		Front: IP40, Screw terminal: IP20	Front: IP40, Screw terminal: IP20
Pollution degree	2 (IEC 60664-1, par. 4.6.2)	2 (IEC 60664-1, par. 4.6.2)	2 (IEC 60664-1, par. 4.6.2)	2 (IEC 60664-1, par. 4.6.2)
Operating temperature	-20°C to +50°C	-20°C to +50°C	-20°C to +50°C	-20°C to +50°C
Storage temperature	-50°C to +85°C	-50°C to +85°C	-50°C to +85°C	-50°C to +85°C
Humidity (non condensing)	20 to 80 %	20 to 80 %	20 to 80 %	20 to 80 %
Main features	Local bus / Energy reading	Wireless universal dimmer with energy reading		Load: 10 W x 4 Local bus
References				
With energy reading	SH2D500WE230			
Without energy reading	SH2D500W1230			
230 VAC	SHJWD200WE230			
115 VAC	SHJWD200WE115			
Capacitive push buttons	SHJWD200WExLS230			
			SH2D10V424	SH2SSTRI424

Building automation

	Energy meter modules		Digital input module	Fire damper
Function	Dupline® connection	Wireless	4 inputs	I/O module
				

Dimensions (mm)	2-DIN module	40 x 45 x 31	2-DIN module	150 x 110 x 70
Functions	Energy meter with direct connection up to 16 A	Energy meter with direct connection up to 16 A	Input module, configurable as contact or pulse counter	I/O-module for control of two fire dampers

Electrical specifications

Inputs			4	4
Outputs				2 (T6 ONLY)
Power supply	115...240 VAC	115...240 VAC	24 VDC ± 20%	24...230 VAC





General specifications

LEDs	Green, yellow, red	Green, blue	Green, yellow, red	Green, yellow (3)
Mounting	DIN-rail (2 modules)		DIN-rail (2 modules)	Box ready for wall mounting
Degree of protection	Front: IP40, Screw terminal: IP20		Front: IP40, Screw terminal: IP20	IP55
Pollution degree	2 (IEC 60664-1, par. 4.6.2)	2 (IEC 60664-1, par. 4.6.2)	2 (IEC 60664-1, par. 4.6.2)	2 (IEC 60664-1, par. 4.6.2)
Operating temperature	-20°C to +50°C	-20°C to +50°C	-20°C to +50°C	0°C to +50°C
Storage temperature	-50°C to +85°C	-50°C to +85°C	-50°C to +85°C	-50°C to +85°C
Humidity (non condensing)	20 to 80 %	20 to 80 %	20 to 80 %	20 to 90 %
Main features	Values readout: A, V, W, W _{dmd} , VA, var, PF, kWh	Values readout: A, V, W, W _{dmd} , VA, var, PF, kWh	Voltage free, NPN, PNP, counter	Box ready for decentral mounting near dampers

References

	SH2INDI424		
115...230 VAC	SH2EM16A230		
230 VAC		SHJWEM16A230	SBB4I2O230T6
115 VAC		SHJWEM16A115	
24 VDC			SBB4I2O24T6
Bus powered			SBB4I

Building automation

	Transparent module	Analogue output modules	Analogue input modules	
Function		0 to 10 V output	Input module	Pulse counter
				
Dimensions (mm)	8.5 x 90 x 67	50 x 30 x 18	50 x 30 x 18	28 x 14 x 10
Functions	Transparent module for simplifying the wiring of the home installation	Output module with 2 analogue outputs	Input module with 2 analogue inputs	Decentral 4 input pulse counter module
Electrical specifications				
Inputs			2 x 0-20 / 4-20 mA inputs	
Outputs		2 x 0-10 VDC		
Power supply	No power supply needed	24 VDC	24 VDC	Powered by bus
General specifications				
Mounting	DIN-rail	Inside wall box or environmental sensor housings	Inside wall box or environmental sensor housings	Small sized plug-in
Degree of protection	Front: IP40, Screw terminal: IP20	IP20	IP20	IP20
Pollution degree	2 (IEC 60664-1, par. 4.6.2)	2 (IEC 60664-1, par. 4.6.2)	2 (IEC 60664-1, par. 4.6.2)	
Operating temperature	-20°C to +50°C	0°C to +50°C	0°C to +50°C	0°C to +50°C
Storage temperature	-30°C to +70°C	-50°C to +85°C	-50°C to +85°C	-50°C to +70°C
Humidity (non condensing)	20 to 80 %	20 to 90 %	20 to 90 %	20 to 90%
References				
	SH1DUPFT	SHPOUTV224	SHPINA224	
50 inputs				SHPINCTS04
Contact inputs				SHPINCNT4

Building automation

Analogue input modules

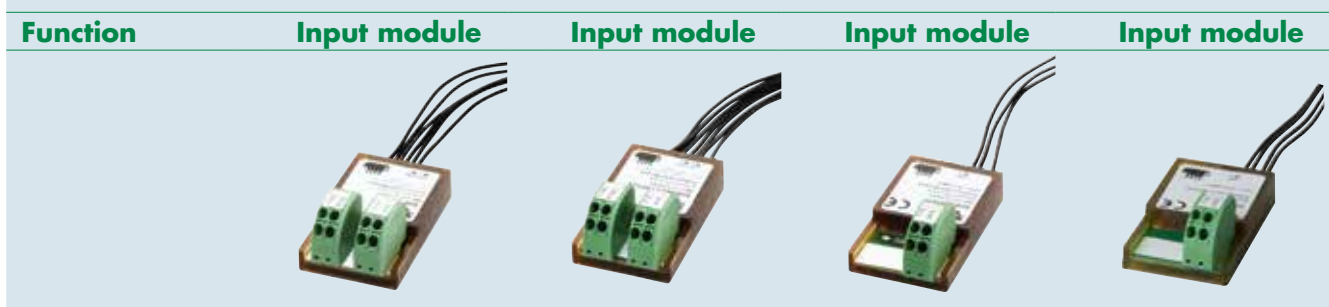

Dimensions (mm)	50 x 30 x 18	50 x 30 x 18	50 x 30 x 18	50 x 30 x 18
Functions	Input module with 3 analogue inputs	Input module with 4 analogue inputs	Input module with 2 analogue inputs	Input module with 2 analogue inputs

Electrical specifications

Inputs	3 x 0-10 VDC	2 x 0-10 VDC, 1 x thermistor 10K3 input 1 x variable resistor 1-11 K Ω	1 x thermistor 10K3 1 x variable resistor 1-11 K Ω	2* Ni1000/Pt1000 inputs
Power supply	24 VDC	24 VDC	Bus	Bus

General specifications

Mounting	Inside wall box or environmental sensor housings	Inside wall box or environmental sensor housings	Inside wall box or environmental sensor housings	Inside wall box or environmental sensor housings
Degree of protection	IP20	IP20	IP20	IP20
Pollution degree	2 (IEC 60664-1, par. 4.6.2)	2 (IEC 60664-1, par. 4.6.2)	2 (IEC 60664-1, par. 4.6.2)	2 (IEC 60664-1, par. 4.6.2)
Operating temperature	0°C to +50°C	0°C to +50°C	0°C to +50°C	0°C to +50°C
Storage temperature	-50°C to +85°C	-50°C to +85°C	-50°C to +85°C	-50°C to +85°C
Humidity (non condensing)	20 to 90 %	20 to 90 %	20 to 90 %	20 to 90 %

References

	SHPINV324	SHPINV2T1P124	SHPINT1P1	SHPINNI2
--	------------------	----------------------	------------------	-----------------

Building automation

Light switch interfaces

Function	Input module	Input / output
----------	--------------	----------------



Dimensions (mm)	28 x 28 x 10	28 x 28 x 10
Functions	Input module for voltage free outputs	Input / output module for voltage free outputs and PNP transistor inputs

Electrical specifications

Inputs	4/8	4
Outputs		4 PNP
Power supply	Powered by bus	Powered by bus



General specifications

LEDs		
Mounting	In a junction box or behind a switch/pushbutton input	In a junction box or behind a switch/pushbutton input
Degree of protection	IP20	IP20
Operating temperature	0°C to +50°C	0°C to +50°C
Storage temperature	-20°C to +70°C	-20°C to +70°C
Humidity (non condensing)	20 to 80%	20 to 80 %

References



4 contacts	BDB-INCON4-U	
8 contacts	BDB-INCON8-U	
Output voltage 3.3 V		BDB-IOCP8-U
Output voltage 8 V		BDB-IOCP8A-U

Building automation

Input modules			
Function	Digital	Voltage	Wireless
			
Dimensions (mm)	89 x 66 x 29	28 x 28 x 10	40 x 45 x 31
Functions	Input module for voltage free outputs or NPN transistor outputs	Opto-isolated input voltage module, 90-265 VAC	Decentral 4 input and pulse counter module. Operating distance 700 m open space
Electrical specifications			
Inputs	4-contact or NPN transistor inputs	90 - 265 VAC	
Power supply	Powered by bus	Powered by bus	115...240 VAC
General specifications			
LEDs	Green, yellow, red		Green, blue
Degree of protection	IP20	IP20	
Pollution degree		3 (IEC 60664)	2 (IEC 60664-1, par. 4.6.2)
Operating temperature	-20°C to +50°C	-20°C to +50°	-20°C to +50°C
Storage temperature	-50°C to +85°C	-50° to +70°C	-50°C to +85°C
Humidity (non condensing)	20 to 80%	20 to 80%	20 to 80 %
References			
	BDD-INCON4-U	BDA-INVOL-U	
4 contacts			SHJWINS04230, SHJWINS04115

Building automation

Light switches

Function	4 pushbutton	4 pushbutton	4 pushbutton + PIR + Luxmeter
			
Dimensions (mm)	44 x 44 / 55 x 55	44 x 44 / 55 x 55	44 x 44 / 55 x 55
Functions	Light switch for building automation applications	Wireless light switch for building automation applications	Light switch and PIR sensor for detecting presence and/or movement in indoor installations

Electrical specifications

Number of switches	4	4	4
Power supply	Powered by bus	Supplied by battery, type Lithium button 2450 3 V	Powered by bus

General specifications

Colour	Black/white	Black/white	Black/white
LEDs	White/blue	Red/blue	White/blue
Mounting	Compatible with many types of wall boxes see datasheet	Compatible with many types of wall boxes see datasheet	Compatible with many types of wall boxes see datasheet
Degree of protection	IP20	IP20	IP20
Pollution degree	3 (IEC 60664)	3 (IEC 60664)	3 (IEC 60664)
Operating temperature	-20°C to +50°C	-20°C to +50°C	0°C to +50°C
Storage temperature	-30°C to +60°C	-30°C to +60°C	-20°C to +70°C
Humidity (non condensing)	20 to 80%	20 to 80%	20 to 80%
Other functions	Humidity and temperature sensor (...TH)	55x55: Flat design, mountable on any surface, embedded temperature sensor	Operating distance: 8 m Angle: 90°
Remarks	Approved according to UL60950	Approved according to UL60950	Approved according to UL60950

References

44 x 44 Wallbox Btcino, Niko, Fuga	B4X-LS4-U	SHA4XWLS4	SHA4XLS4P90L
55 x 55 Compatible with many types of wall boxes - see datasheet	B5X-LS4-U	SHE5XWLS4WF SHE5XWLS4BF	SHE5XLS4P90L
55 x 55 Compatible with many types of wall boxes - see datasheet Temperature		SHE5XWLS4WFT SHE5XWLS4BFT	
44 x 44 Wallbox Btcino, Niko, Fuga Temperature and humidity	SHA4XLS4TH		
55 x 55 Compatible with many types of wall boxes - see datasheet Temperature and humidity	SHE5XLS4TH		

Building automation

Temperature display

Movement / Presence sensors

Function

150° PIR/ Luxmeter

90° PIR/ Luxmeter



Dimensions (mm)	44 x 44 / 55 x 55	44 x 44 / 55 x 55	44 x 44 / 55 x 55
Functions	Temperature controller with display	PIR sensor for detecting presence and/or movement in indoor installations	PIR sensor for detecting presence and/or movement in indoor installations

Electrical specifications

Number of switches	4		
Power supply	Powered by bus	Powered by bus	Powered by bus

General specifications



Colour	White/black	White/black	White/black
LEDs	White/blue	White/blue	White/blue
Mounting	Wallbox Btcino, Niko, Fuga / Elko, Gira, Jung	Wallbox Btcino, Niko, Fuga / Elko, Gira, Jung	Wallbox Btcino, Niko, Fuga / Elko, Gira, Jung
Degree of protection	IP20	IP20	IP20
Pollution degree	3 (IEC 60664)	3 (IEC 60664)	3 (IEC 60664)
Operating temperature	-10°C to +50°C	-20°C to +50°C	0°C to +50°C
Storage temperature	-20°C to +70°C	-30°C to +70°C	-20°C to +70°C
Humidity (non condensing)	20 to 80%	20 to 80%	20 to 80%
Remarks	Approved according to UL60950	Operating distance: 8 m Angle: 150°	Operating distance: 8 m Angle: 90°

References

44 x 44 Wallbox Btcino, Niko, Fuga	SHA4XTENDIS SHA4XLS2TENDIS	SHA4XP150/SHA4XP150L	B4X-PIR90-U
55 x 55 Compatible with many types of wall boxes - see datasheet	SHE5XTENDIS SHE5XLS2TENDIS	SHE5XP150/SHE5XP150L	B5X-PIR90-U
44 x 44 Wallbox Btcino, Niko, Fuga + luxmeter			SHA4XP90L
55 x 55 Compatible with many types of wall boxes - see datasheet + luxmeter			SHE5XP90L



Building automation

Movement / Presence sensors



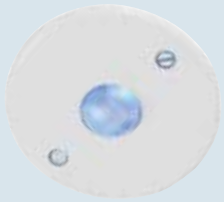
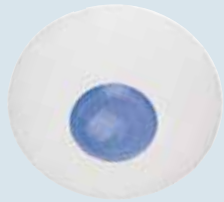

Function	90° PIR/ Luxmeter	90° PIR/ Luxmeter
		
Dimensions (mm)	104 x 55 x 57	67 x 52 x 34
Functions	PIR sensor for detecting presence and/or movement in indoor installations	PIR sensor for detecting presence and/or movement in indoor / outdoor installations
Electrical specifications		
Power supply	Powered by bus	Powered by bus
General specifications		
Colour	White	White
LEDs	Red	Red
Mounting	Wall mounting	Wall mounting
Degree of protection	IP40	IP64 / IP20
Pollution degree	3 (IEC 60664)	3 (IEC 60664)
Operating temperature	0°C to +50°C	-20°C to +50°C
Storage temperature	-20°C to +70°C	-30°C to +70°C
Humidity (non condensing)	20 to 80%	20 to 80%
Main features	Operating distance: 12 m Angle: 90°	Operating distance: 0.5 - 15 m Angle: 90°
References		
	BSD-PIR90-U	
Luxmeter	SHSDP90L	
Outdoor		BSP-PIR90-U
Indoor		BSP-PIR90A-U
Outdoor + luxmeter		SHSPP90L
Indoor + luxmeter		SHSPP90LA

Building automation





Movement / Presence sensors

Function	90° PIR/ Luxmeter	360° PIR/ Luxmeter	360° PIR/ Luxmeter
			
Dimensions (mm)	Ø 76 x 25	Ø 90 x 40	Ø 96.5 x 70.6
Functions	PIR sensor for detecting presence and/or movement in indoor installations	PIR sensor for detecting presence and/or movement in indoor installations with a built-in luxmeter	PIR sensor for detecting presence and/or movement in indoor and outdoor installations with a built-in luxmeter
Electrical specifications			
Power supply	Powered by bus	Powered by bus	Powered by bus
General specifications			
Colour	White	White	White
LEDs	Blue	Blue	Blue
Mounting	LK ceiling box PL52 or PL55	Ceiling mounting	Ceiling mounting
Degree of protection	IP20	IP20	IP20, IP55
Pollution degree	3 (IEC 60664)	3 (IEC 60664)	3 (IEC 60664)
Operating temperature	0°C to +50°C	0°C to +50°C	0°C to +50°C
Storage temperature	-20°C to +70°C	-20°C to +70°C	-20°C to +70°C
Humidity (non condensing)	20 to 80%	20 to 80%	20 to 80%
Main features	Detection range: ≤ Ø 8 m Angle: 90°	Detection range: ≤ Ø 7.5 m Angle: 360° Lens: dual detecting zones	Detection range: Ø 14 m and Ø 24 m Angle: 360° Detection Area: programmable
References			
	BSB-PIR90-U	SHSQP360L	
Luxmeter	SHSBP90L		
24 m, built-in			SBQP360L24M
14 m, built-in			SHQP360L7M
24 m, surface			SBQP360L24MF
24 m, surface, IP55			SBQP360L24MFO
14 m, surface			SHQP360L7MF
14 m, surface, IP55			SHQP360L7MFO



Building automation

	Touch displays	Environmental sensors		
Function	Graphical display	Display	RGB LED	Blind
				
				
Dimensions (mm)	187 x 147	80 x 90 x 26	80 x 90 x 26	80 x 90 x 26
Functions	High definition 7" colour touchscreen, BACnet, Modbus and KNX gateway	Room sensors for CO ₂ , temperature and %RH measurement - with display	Room sensors for CO ₂ , temperature and %RH measurement - with LED indication	Room sensors for CO ₂ , temperature and %RH measurement
Electrical specifications				
Power supply	24 VDC ± 20%	Bus	Bus	Bus
General specifications				
Mounting	Wall mounting	Wall mounting	Wall mounting	Wall mounting
Indication	Display	Display	Red, green, blue	None
Degree of protection	Front: IP66 Rear: IP20	IP20	IP20	IP20
Pollution degree		2 (IEC 60664-1, par. 4.6.2)	2 (IEC 60664-1, par. 4.6.2)	2 (IEC 60664-1, par. 4.6.2)
Operating temperature	0°C to +50°C	-20°C to +50°C	-20°C to +50°C	-20°C to +50°C
Storage temperature	-20°C to +70°C	-40°C to +70°C	-40°C to +70°C	-40°C to +70°C
Humidity (non condensing)	5 to 85% RH	0 to 90%	0 to 90%	0 to 90%
Main features	Windows CE, 7", 800 x 480 pixel, Ethernet port, BACnet, Modbus, KNX, data logging, configurable graphical display and alarms management	CO ₂ measuring range: 0 to 2000 ppm CO ₂ measurement: Dual source infrared NDIR technology Temperature measuring range: -20°C to +50°C (-4 to 122°F) Humidity measuring range: 0 to 100 %RH	CO ₂ measuring range: 0 to 2000 ppm CO ₂ measurement: Dual source infrared NDIR technology Temperature measuring range: -20°C to +50°C (-4 to 122°F) Humidity measuring range: 0 to 100 %RH	CO ₂ measuring range: 0 to 2000 ppm CO ₂ measurement: Dual source infrared NDIR technology Temperature measuring range: -20°C to +50°C (-4 to 122°F) Humidity measuring range: 0 to 100 %RH
References				
7", 800 x 480 pixel	BTM-T7-24			
Display, CO ₂ + temperature	SHSUCOT			
Display, CO ₂ + temperature + humidity	SHSUCOTH			
Display, temperature + humidity	SHSUTH			
Display, temperature	SHSUTD			
RGB Led, CO ₂ + temperature	SHSUCOTL			
RGB Led, temperature + humidity	SHSUCOTHL			
CO ₂ + temperature	SHSUCOT			
CO ₂ + temperature + humidity	SHSUCOTH			
Temperature + humidity	SHSUTH			
Temperature	SHSUT			





Building automation

	Smoke	Water	Window	Alarm
Function	Smoke detector	Water sensor	Wireless sensor	Keypad
				
Dimensions (mm)	Ø 100 x 51	70 x 39 x 15.5	Sensor: 60 x 30 x 15.5 Magnet: 32 x 10.2 x 11.5	130 x 50 x 8
Functions	Smoke detector for home/ building applications	Water detection sensor for home/building applications	Wireless, battery powered reed sensor with additional input	Programmable keypad for building access control and alarm control in indoor and outdoor applications
Electrical specifications				
Inputs			Reed, voltage free	12 push buttons
Power supply	Powered by bus / 9 VDC battery	Powered by bus	Battery	9-17 VDC
General specifications				
Colour	White	White	White	Black / white
LEDs	Red		Red / blue	Yellow, red, green, programmable
Mounting	Ceiling mounting	Wall mounting	Wall mounting, screw and double side tape	Wall box mounting
Degree of protection	IP43	IP67	IP20	IP67
Pollution degree			2 (IEC 60664-1, par. 4.6.2)	
Operating temperature	0°C to +50°C	-20°C to +50°C	-20°C to +50°C	-15°C to +60°C
Storage temperature	-5°C to +85°C	-50°C to +85°C	-30°C to +85°C	-30° to 80°C
Humidity (non condensing)	20 to 80%	20 to 80%	20 to 80%	100,00%
Main features	Detection area: 60 m ²	Input for Felson probe		28 user-programmable codes, Buzzer output
References				
		BSF-WAT-U		BACC-KEYPAD-DC-U
Battery backup	BSG-SMOA-U			
No battery backup	BSG-SMO-U			
Reed contact			SHDWWISEN	
Reed contact + voltage free			SHDWWISENIN1	



Building automation

	Environmental sensor	Light	Temperature
Function	Weather station	Luxmeter	Outdoor
			
Dimensions (mm)	96 x 77 x 118	55 x 53 x 36	67 x 35 x 15
Functions	Weather station for measurement of temperature, wind speed, brightness and precipitation	Luxmeter for indoor / outdoor installations	Temperature sensor for indoor and outdoor applications
Electrical specifications			
Power supply	12 to 40 VDC / 12 to 28 VAC	Powered by bus	Powered by bus
General specifications			
Colour	White	White	Light grey
Mounting	Wall mounting	Wall mounting	Direct wall mounting
Connection			Cable / plug
Degree of protection	IP44	IP44	IP67
Pollution degree			
Operating temperature	-30°C to +50°	-30°C to +60°C	-40°C to +60°C
Storage temperature	-30°C to +70°C		-55°C to +85°C
Humidity (non condensing)	5 to 95%		20 to 80%
Main features	GPS receiver	Measuring range: 0 to 20 kLux	
Remarks			Approved according to UL60950
References			
	SHOWEAGPS	BSH-LUX-U	
Cable, 2 m			BSI-TEMANAB-U
Plug, M12			BSI-TEMANA-U

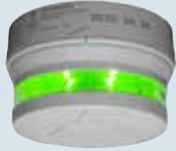

Parking guidance system

	Carpark Master generator	Carpark Controller	Carpark Server	Carpark Display interface
Types	SBP2MCG324	UWP30	SBP2CPY24	SBP2DI48524
				
Dimensions	2-DIN module	2-DIN module	2-DIN module	2-DIN module
Functions	The Carpark Master Generator provides 28 VDC power and bus on a 3-wire connection with up to 90 sensors	Programmable controller with functions for parking guidance, booking, energy saving. One controller can manage up to 7 Dupline® networks (630 spaces). Compatible with Carlo Gavazzi meters, analyzers and building automation solutions. It provides easy integration with local or remote SCADA/Server solutions and a configurable Web interface for control, analysis, alerting and reporting	Carpark server to link together up to 10 carpark controllers UWP30 in a TCP/IP network to manage large networks (up to 6300 spaces)	Module which interfaces Dupline and Modbus RTU for Carpark displays
Housing type	Mounting on DIN-rail	Mounting on DIN-rail	Mounting on DIN-rail	Mounting on DIN-rail
Electrical specifications				
Features/Signal types	3-wire master generator for carpark sensors and LED indicators. Other smartbuilding components such as PIR, CO sensors and HVAC modules can be connected to the same bus	Various I/O's and function parameters are available as BACnet/IP objects through the Ethernet port, thereby allowing seamless integration with any building management system, thereby allowing energy saving functions for lighting and ventilation	The webserver aggregates data from multiple carpark controllers in a single centralized database, allowing the user to access it as a graphical user interface through a PC with a standard Web-browser	Interface module between Dupline® and Modbus RTU. RS485 to display. Up to 300 m
Power supply	28 VDC	24 VDC	24 VDC	24 VDC
General specifications				
Degree of protection	IP20	IP20	IP20	IP20
Pollution degree	-20°C to +50°C	-25°C to +50°C	-25°C to +50°C	-20°C to +50°C
Operating temperature	-50°C to +85°C	-30°C to +70°C	-30°C to +70°C	-50°C to +85°C
References				
Carpark master generator	SBP2MCG324			
Carpark controller		UWP30RSEXXX		
Carpark server			SBP2CPY24	
Display interface				SBP2DI48524





Parking guidance system

	Sensor	LED indicator	Baseholder
Types	SBPSUSLxx	SBPILED	SBPBASEx
			
Dimensions (mm)	Ø116 x 78	Ø116 x 50	Ø116 x 26 / Ø116 x 44
Functions	Ultrasonic sensors for detection of cars and with RGB LED indication	LED indicator with RGB LED indication	Baseholder for Carpark sensors and LED indicator
Housing type	Direct mounting on base holder to rail, ceiling or conduit/pipe	Direct mounting on base holder to rail, ceiling or conduit/pipe	Direct mounting of base holder on rail, ceiling or conduit/pipe
Electrical specifications			
Features/Signal types	3-wire sensor with built-in RGB LEDs. Programmable from the UWP tool configuration software. Can detect available or occupied spaces or be used in count systems	3-wire LED indicator with built-in RGB LEDs. Programmable from the UWP tool configuration software. To be mounted outside the parking space	Baseholder for sensors and LED indicators. No programming. Only wire connected
Power supply	3-wire system with Dupline [®] and sensor supply	3-wire system with Dupline [®] and sensor supply	
General specifications			
Degree of protection	IP34	IP34	IP34
Operating temperature	-40°C to +70°C	-40°C to +70°C	-40°C to +70°C
Storage temperature	-40°C to +85°C	-50°C to +85°C	-50°C to +85°C
References			
45 degree sensor	SBPSUSL45		
Vertical sensor	SBPSUSL		
Counting sensor	SBPSUSCNT		
LED indicator		SBPILED	
Baseholder for cable tray / conduit			SBPBASEA
Baseholder for ceiling			SBPBASEB



Parking guidance system

Displays			
Types	DIS A RSE	DIS B RSE	DIS C RSE
			
Dimensions (mm)	260 x 150 x 80	520 x 150 x 80	520 x 250 x 80
Functions	Bright RGB LED matrix <ul style="list-style-type: none"> Selectable symbols Visible at a distance of more than 50 m Brightness control Settings are configurable from the embedded webserver Indoor and outdoor use Extended temperature range down to -30°C Configuration: up to 4 digits or 2 symbols 	Bright RGB LED matrix <ul style="list-style-type: none"> Selectable symbols Visible at a distance of more than 50 m Brightness control Settings are configurable from the embedded webserver Indoor and outdoor use Extended temperature range down to -30°C Configuration: up to 4 digits and 2 symbols 	Bright RGB LED matrix <ul style="list-style-type: none"> Selectable symbols Visible at a distance of more than 50 m Brightness control Settings are configurable from the embedded webserver Indoor and outdoor use Extended temperature range down to -30°C Configuration: up to 4 digits and 2 symbols and running text. Can combine text and digits.
Electrical specifications			
Power supply	24 VDC	24 VDC	24 VDC
Features			
	Guides the driver by showing a moving green arrow, a red cross, or other symbols, as well as the number of free spaces for a lane or area in the carpark. RS485 communication	Guides the driver by showing a moving green arrow, a red cross, or other symbols, as well as the number of free spaces for a lane or area in the carpark. RS485 communication	Shows a running text and a combination with up to 4 digits and two symbols. The text can be chosen by the customer. RS485 communication
General specifications			
Degree of protection	IP55	IP55	IP24
Pollution degree	3 (IEC 60664)	3 (IEC 60664)	3 (IEC 60664)
Operating temperature	-30°C to +55°C	-30°C to +55°C	-30°C to +55°C
Humidity	10 to 90% non condensing	10 to 90% non condensing	10 to 90% non condensing
References			
One tile	DISARSE		
Two tiles	DISBRSE		
Four tiles	DISCRSE		

Parking guidance system

	Carpark long range wireless sensor	Carpark NB-IoT wireless sensor	Carpark Concentrator for wireless sensor	Videobox
Types	SBPWSI1	SBPWSI2	SBPCWSI1xxx	SBPVBE
				
Dimensions	91 x 96 x 84 mm	91 x 96 x 84 mm	300 x 175 x 92 mm	160 x 51 x 127 mm
Functions	Proprietary long range wireless and LoRaWAN [®] sensor for smart parking installations	NB-IoT sensor for smart parking installations	Concentrator for proprietary LoRa [®] wireless sensor	The videobox converts the IP cameras images into occupancy information
Housing type	Recessed	Recessed	Mounting on pole/wall	Mounting on DIN-rail
Electrical specifications				
Features/Signal types	It detects the occupied/free status of the parking bays by using the earth's magnetic field. Operating frequency: 868 MHz. The SBPWSI1 sensor can be configured to transmit the parking bay status to the central gateway SBPCWSI1 using Long Range wireless communication or directly to the LoRaWAN [®] networks	It detects the occupied/free status of the parking bays by using the earth's magnetic field. The SBPWSI2 sensor communicates directly to the NB-IoT bridges and then to the cloud	The SBPCWSI1 is a compact Long Range wireless gateway designed to collect occupancy information from SBPWSI1 sensors. The occupancy information is transmitted to the cloud in real-time by means of the wireless 4G/LTE cellular network or LAN connection and UWP3.0/SBP2CPY platform gathers data by means of the cloud	The SBPVBE is a small PC to which up to 8 IP cameras can be connected. It works in accordance with the GDPR: after analysing the images, they are automatically destroyed so that there is no trace of sensitive content
Power supply	Battery	Battery	24 VDC/230 VAC	110 VAC/230 VAC
General specifications				
Degree of protection	IP68	IP68	IP66	IP54
Operating temperature	-40°C to +85°C	-40°C to +85°C	-20°C to +60°C	-20°C to +60°C
References				
Wireless sensor	SBPWSI1	SBPWSI2		
Concentrator			SBPCWSI1230 SBPCWSI124	
Videobox				SBPVBE

DuplineSafe





	Input module	Output module
Types	GS7510 2101	GS3830 0143
		
Dimensions (mm)	57.5 x 36.0 x 16.4	144 x 77 x 70
Functions	Bus-powered safety input module	DuplineSafe relay output module. Monitors up to 63 DuplineSafe inputs
Housing type		DIN-rail mounting H8
Electrical specifications		
Number of channels	2	2
Features/Signal types	1 x NC contact	2 x NO Relays Force Guided contact
Power supply	Powered through the Dupline® network	230 VAC ± 15%
General specifications		
Degree of protection	IP67	IP20
Pollution degree	3 (IEC 60664)	3 (IEC 60664)
Operating temperature	-40°C to +50°C	-25°C to +50°C
Storage temperature	-40°C to +70°C	-30°C to +70°C
Humidity (non condensing)	20 to 80%	20 to 80%
Remarks	Approved by TÜV Rheinland according to IEC/EN 61508, EN 62061 and ISO/EN 13849-1 PL e	Approved by TÜV Rheinland according to IEC/EN 61508, EN 62061 and ISO/EN 13849-1 PL e
References		
Cable connection	GS7510 2101	
Cable connection cULus approved	GS7510 2192	
Plug connector	GS7510 2101-1	
Plug connector cULus approved	GS7510 2192-1	
Output relay		GS3830 0143

DuplineSafe

Gateway / interface

Types	GS33910060800	GS3891 0125	GSTI 50
			
Dimensions (mm)	90 x 35 x 58.5	144 x 77 x 70	55 x 70 x 15
Functions	Profinet gateway with function as slave. Up to 7 master generators can be connected via the HS RS485 bus. All Dupline® signals from master generators are available on Profinet	Profibus-DP passive Gateway with Safety mapping	Dupline® Modbus interface module with Safety mapping
Housing type	DIN-rail mounting H2	DIN-rail mounting H8	Compact plastic housing
Electrical specifications			
Features/Signal types	Reads/controls up to 7 Dupline networks through Profinet. Miniwebserver for diagnostics of Profinet and Dupline® networks available	Reads/controls up to 128 inputs/outputs through Profibus-DP, Communication speed up to 12 MBaud	
Power supply	24 VDC	115-230 VAC	Powered by the RS485 com port
General specifications			
Degree of protection	IP20	IP20	IP20
Operating temperature	-20°C to +50°C	0°C to +50°C	-20°C to +60°C
Storage temperature	-30°C to +85°C	-20°C to +85°C	-30°C to +85°C
Humidity (non condensing)	20 to 80%	20 to 80%	
Remarks	Certified by PNO	Certified by PNO	Supports Modbus RTU function code 3 and code 16
References			
	GS33910060800	GS38910125230	GSTI 50

DuplineSafe

	Optical fibre converter	Repeater	Configuration tool	
Types	GS3492/GS3493	GS3892 0000	GS7380 0080	GS7380 0081
				
Dimensions (mm)	77 x 72 x 70	77 x 144 x 70	28 x 90 x 145	25 x 50 x 100
Functions	Optical repeater for converting DuplineSafe from electrical to optical transmission media	DuplineSafe signal repeater for extension of transmission distance	Configuration and test unit for DuplineSafe	USB Configuration unit for DuplineSafe
Housing type	DIN-rail, H4	DIN-rail H8	Handheld	Handheld
Electrical specifications				
Number of channels	Adjusts automatically	Adjusts automatically		
Features/Signal types	All Dupline® signal types	Regenerates the Dupline® signal carrier through channel generator output		Windows based programming tool for safety output relay module and safety input modules
Power supply	230 = 115/230 VAC	024 = 024 VAC 115 = 115 VAC 230 = 230 VAC	9 V battery 6LR61	Supplied by the USB port
General specifications				
Degree of protection	IP20	IP40	IP40	IP40
Pollution degree				3 (IEC 60664)
Operating temperature	0°C to +50°C	0°C to +50°C	0°C to +50°C	0°C to +50°C
Storage temperature	-20°C to +85°C	-50°C to +85°C	-20°C to +70°C	-20°C to +60°C
Remarks	Operates pair-wise. Runs on 50/125, 62.5/125 or 100/140 micro m with STN connectors		Adapt 7380 is included	
References				
		GS3892 0000	GS7380 0080	GS7380 0081
Optical/electrical converter	GS3492 0000			
Electrical/optical converter	GS3493 0000			

DuplineSafe

Master generator

Types

GS3390000800A



Dimensions (mm)	90 x 35 x 58.5
Functions	Master channel generator which provides the Dupline® bus carrier with power and communication for the connected Dupline® units
Housing type	DIN-rail mounting H2

Electrical specifications

Number of channels	128
Features/Signal types	The unit supports Digital in/out, Analink in/out, Mux BCD in/out, 8 bit in/out and DuplineSafe in High Dupline® current output (450 mA)
Power supply	24 VDC

General specifications



Degree of protection	IP20
Operating temperature	-20°C to +50°C
Storage temperature	-50°C to +85°C
Humidity (non condensing)	20 to 80%

References





Dupline® Master Channel Generator	GS3390000800A
-----------------------------------	----------------------

Fieldbuses - Industrial



Channel generators/interfaces

Types	SD2DUG24	G3496	G3800
			
Dimensions (mm)	35 x 90 x 58,5	77 x 72 x 70	77 x 144 x 70
Functions	Standard channel generator	Plug & Play RS232/RS485 Interface with built-in protocols for specific PLC brands and Modbus	Controller and Modbus Interface with built-in GSM Modem (option) or external Radio Modem Logger (option)
Housing type	DIN-rail, H2	DIN-rail, H4	DIN-rail, H8
Electrical specifications			
Number of channels	Selectable	Selectable	Selectable
Features/Signal types	2 and 3-wire operation with DC-power on the 3 rd wire. The unit supports Digital in/out, Analink in/out, Mux BCD in/out, 8 bit in/out and Dupline	Possibility of 3-wire operation with DC-power on the 3 rd wire	4 x Contact/PNP input +4 x PNP 10-30 VDC output 2 x RS232+1 x RS485. Possibility for alarms, monitoring and control via SMS messages
Power supply	24 VDC	700 = 20-30 VDC	800 = 10-30 VDC 230 = 115-230 VAC
General specifications			
Degree of protection	IP20	IP20	IP20
Operating temperature	-20°C to +50°C	0°C to +50°C	0°C to +50°C
Storage temperature	-50°C to +85°C	-50°C to +85°C	-20°C to +85°C
Remarks	Modbus gateway, RS485	Built-in protocol for specific PLC brands for easy interfacing	Up to 32 controllers can be networked together via RS485 or Ethernet via converter module
References			
Channel Generator	SD2DUG24		
Omron		G3496 0004	
Allen-Bradley		G3496 0006	
Matsushita		G3496 0009	
-GSM Modem, -RS485			G3800 0015
-GSM Modem, +RS485			G3800 0016

Fieldbuses - Industrial



	Channel generators/interfaces		Digital input modules	
Types	G3891	GTI50	G3410 5501	G3420
				
Dimensions (mm)	77 x 144 x 70	55 x 70 x 15 mm	77 x 72 x 70	77 x 72 x 70
Functions	Gateways to Fieldbus systems (Profibus-DP, DeviceNet etc.)	Dupline® Modbus RTU Interface module for Text Displays and Touch screens	Dupline® powered transmitter with 8 monostable voltage free contacts	Input module for external supply with optoisolated inputs
Housing type	DIN-rail, H8	Closed plastic housing with 25p male sub-D	DIN-rail, H4	DIN-rail, H4
Electrical specifications				
Number of channels	Selectable		8	8
Features/Signal types		Supports Modbus RTU function code 3 and code 16	Voltage free input contacts	Contact/NPN Voltage (6-265 VAC/DC)
Power supply	230 = 115/230 VAC	Powered by RS485 port	Powered by Dupline®	024 = 24 VAC 115 = 115 VAC 230 = 230 VAC 800 = 10-30 VDC
General specifications				
Degree of protection	IP20	IP20	IP20	IP20
Operating temperature	0°C to +50°C	-20°C to +60°C	-20°C to +50°C	-20°C to +50°C
Storage temperature	-20°C to +85°C	-50°C to +85°C	-50°C to +85°C	-50°C to +85°C
Remarks			Low power consumption	
References				
	GTI50			
Profibus-DP with C. G.	G3891 0020			
Profibus-DP analogue output multiplex	G3891 0021			
DeviceNet	G3891 0050			
Modbus/TCP	G3891 0052			
Profibus-DP passive	G3891 0120			
8 channel	G3410 5501			
Contact/NPN				G3420 5501
Voltage				G3420 5502

Fieldbuses - Industrial

	Digital input modules		Digital I/O modules
Types	G5010	G8810 2201	G3440 4443
			
Dimensions (mm)	49 x 22.5 x 56	28 x 14 x 10	77 x 72 x 70
Functions	Dupline® powered single input Module	Small-sized 2-channel monostable transmitter	Combined I/O module for external supply with optoisolated inputs and relay outputs
Housing type	DIN-rail, Mini-E	Plug-in	DIN-rail, H4
Electrical specifications			
Number of channels	1	2	4
Features/Signal types	Contact input	2 contact inputs for push buttons cULus approved	2 x 6-265 VAC/DC inputs + 2 x SPST relay outputs
Power supply	Powered through the Dupline® network	Supplied by Dupline®	024 = 24 VAC 115 = 115 VAC 230 = 230 VAC 824 = 15-30 VDC
General specifications			
Degree of protection	IP20	IP65	IP20
Operating temperature	-20°C to +50°C	-40°C to +70°C	-20°C to +50°C
Storage temperature	-50°C to +85°C	-40°C to +70°C	-50°C to +85°C
Remarks		Address coding by GAP 1605	
References			
1 channel	G5010 1106		
2 channels	G5010 2206	G8810 2201	
2 input + 2 output SPST			G3440 4443

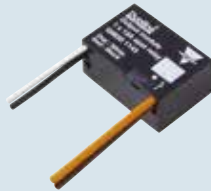

Fieldbuses - Industrial

Digital output modules





Types	G3430 / G3830	G34305545	G8830 1143
			
Dimensions (mm)	77 x 72 x 70 77 x 144 x 70 (H8)	77 x 72 x 70	26 x 39 x 17
Functions	Output modules for external supply with isolated outputs	Central relay module with 8 x SPST relays for resistive loads	Decentral relay module with 1 x SPST relay for control of lights
Housing type	DIN-rail, H4 DIN-rail, H8 (G3830 5543)	DIN-rail, H4	Compact regular, with solid cables. For decentral installation
Electrical specifications			
Number of channels	1, 2, 4, 8	8	1
Features/Signal types	10 A SPDT relay 10 A SPST relay 0.7 A NPN transistor 0.7 A PNP transistor	8 x 16 A/250 VAC relays Inrush current: <130 A	1 x 13 A/250 VAC relay Inrush current: <130 A
Power supply	024 = 24 VAC 115 = 115 VAC 230 = 230 VAC 800 = 10-30 VDC 824 = 15-30 VDC	024 = 24 VAC 115 = 115 VAC 230 = 230 VAC	Powered through the Dupline® network
General specifications			
Degree of protection	IP20	IP20	IP20
Operating temperature	-20°C to +50°C	-5°C to +50°C	0°C to +50°C
Storage temperature	-50°C to +85°C	-50°C to +85°C	-50°C to +85°C
Remarks		Total module load max. 32 A	Recommended minimum load 100 mA / 12 V
References			
2 x 10 A SPDT	G3430 2249		
4 x 5 A SPST	G3430 4443		
4 x 16 A SPST	G3430 4445		
8 x 5 A SPST	G3830 5543		
8 x 0.7 A NPN	G3430 5511		
8 x 0.7 A PNP	G3430 5521		
8 x 16 A SPST (Max. 32 A)		G3430 5545	
1 x 13 A SPST			G8830 1143

Fieldbuses - Industrial





Analogue input modules

Types	G3429 6470	G3210 1161	G3210 1111
			
Dimensions (mm)	77 x 72 x 70	77 x 36 x 70	77 x 36 x 70
Functions	Universal analogue input module for external supply	Analogue input module powered from Dupline® and input signal	Dupline®- powered Analogue input module for Pt100 temperature sensor
Housing type	DIN-rail, H4	DIN-rail, H2	DIN-rail, H2
Electrical specifications			
Number of channels	Selectable	1	1
Features/Signal types	4 x isolated analogue input. Input type individually configurable (0-20 mA, 4-20 mA, 0-10 VDC)	1 x 4-20 mA input	1 x Pt100 3-wire input ranges: (-50°C to +40°C) (+30°C to +120°C) (-10°C to +100°C)
Power supply	024 = 24 VAC 115 = 115 VAC 230 = 230 VAC 800 = 10-30 VDC	Powered through the Dupline® network and 4-20 mA input signal	Powered through the Dupline® network
General specifications			
Degree of protection	IP20	IP20	IP20
Operating temperature	0°C to +50°C	0°C to +50°C	0°C to +50°C
Storage temperature	-20°C to +85°C	-50°C to +85°C	-50°C to +85°C
Remarks	Freely selectable protocol (Analink, Multiplexed BCD or 8-bit)	Uses Analink 8-bit protocol	Uses Analink 8-bit protocol. Built-in cable compensation
References			
Universal analogue output	G3429 6470		
Dupline® powered analogue input		G3210 1161	
+30°C to +120°C			G3210 1112

Fieldbuses - Industrial



	Analogue output modules	Decentral analogue input modules		
Types	G3439 6470	G8810 6265	G8810 6311	G8810 6312
				
Dimensions (mm)	77 x 72 x 70	50 x 30 x 18	50 x 30 x 18	50 x 30 x 18
Functions	Universal analogue output module for external supply	Decentral analogue module with 3 x 0-10 VDC inputs designed for HVAC systems	Decentral analogue module with 2 x 0-10 VDC, 1 x thermistor and 1 x variable resistor inputs designed for HVAC systems	Decentral analogue module with 1 x thermistor and 1 x variable resistor inputs designed for HVAC systems
Housing type	DIN-rail, H4	Compact housing for decentral installation	Compact housing for decentral installation	Compact housing for decentral installation
Electrical specifications				
Number of channels	Selectable	3	4	2
Features/Signal types	4 x analogue outputs. Output type configurable for 0-20 mA, 4-20 mA or 0-10 VDC	3 x 0-10 VDC input	2 x 0-10 VDC input 1 x thermistor 10k3 input 1 x variable resistor 1-11 KΩ input	1 x thermistor 10k3 input 1 x variable resistor 1-11 KΩ input
Power supply	024 = 24 VAC 115 = 115 VAC 230 = 230 VAC 800 = 10-30 VDC	Powered from external 15-30 VDC	Powered from external 15-30 VDC	Dupline® powered
General specifications				
Degree of protection	IP20	IP20	IP20	IP20
Operating temperature	0°C to +50°C	0°C to +50°C	0°C to +50°C	0°C to +50°C
Storage temperature	-20°C to +85°C	-20°C to +85°C	-20°C to +85°C	-20°C to +85°C
Remarks	Freely selectable protocol (Analink, Multiplexed BCD or 8-bit)	Analink protocol 8 bit resolution	Analink protocol 8 bit resolution	Analink protocol 8 bit resolution
References				
Universal analogue output	G3439 6470			
Decentral 3 x input		G8810 6265		
Decentral 4 x input			G8810 6311	
Decentral 2 x input Bus powered				G8810 6312

Fieldbuses - Industrial



	Digital sensors	Temperature sensor	Repeater	Converters
Types	G8910 1101	G8911 1010	D3892 0000	G3492 / G3493
				
Dimensions (mm)	Ø11 x 68	67 x 35 x 15	77 x 144 x 70	77 x 72 x 70
Functions	Dupline® powered magnet proximity switch	Temperature sensor for outdoor use. With built-in PT1000 transducer	Dupline® signal Repeater for extension of transmission distance	Optical repeater for converting Dupline® from electrical to optical transmission media
Housing type	Cylindrical	Flat pack sensor housing	DIN-rail, H8	DIN-rail, H4
Electrical specifications				
Number of channels	1	1	Adjusts automatically	Adjusts automatically
Features/Signal types	Detects proximity of magnet	1 x Analink Range: -30°C to +60°C	All Dupline® signal types. Regenerates the Dupline® signal carrier through channel-generator output	All Dupline® signal types
Power supply	Powered through the Dupline® network	Powered through the Dupline® network	024 = 24 VAC 115 = 115 VAC 230 = 230 VAC	230 = 115/230 VAC
General specifications				
Degree of protection	IP67	IP67	IP20	IP20
Operating temperature	-20°C to +50°C	-25°C to +70°C	0°C to +50°C	0°C to +50°C
Storage temperature	-20°C to +70°C	-55°C to +85°C	-50°C to +85°C	-20°C to +85°C
Remarks	Available in Ø 11 plastic housing or with M14 metal thread	8-bit resolution		Operates pair-wise. Runs on 0/125, 62.5/125 or 100/140 micro m with STN connectors
References				
Ø11	G8910 1101			
M14	G8910 1101 G			
M12 plug		G8911 1010		
Repeater (Booster)			D3892 0000	
Optical/electrical converter				G3492 0000
Electrical/optical converter				G3493 0000

Fieldbuses - Industrial





Accessories

Types	GAP1605	GTU8	G3282 2002 230
			
Dimensions (mm)	120 x 65 x 22	145 x 90 x 28	77 x 36 x 70
Functions	Dupline® coding device for assigning addresses to Dupline® I/O modules and sensors	Dupline® test unit for monitoring and control of Dupline® channels	Dupline® bus separator
Housing type	Handheld	Handheld	H2 Housing
Electrical specifications			
Number of channels	NA	Adjusts automatically	2
Features/Signal types		Digital, multiplexed BCD, 8-bit analogue signals and split I/O. Also prepared to calibrate sensors in Carpark system	Disconnect the secondary side of the Dupline® bus when a short-circuit is detected
Power supply	9 V battery	Powered through the Dupline® network	230 V
General specifications			
Degree of protection	IP40	IP40	IP20
Operating temperature	0°C to +50°C	0°C to +50°C	0°C to +50°C
Storage temperature	-20°C to +60°C	-20°C to +85°C	-20°C to +85°C
Remarks	Options for latching digital signals and for reading multiplexed BCD values		
References			
Programmer	GAP1605		
Monitoring and control unit	GTU8		
Bus separator	G3282 2002 230		



Fieldbuses - Industrial

Accessories			
Types	ADAPT 1605	ANT2	DT01/DT02
			
Dimensions (mm)	25 x 50 x 100	15 x 35 x 120	17.5 x 70 x 77
Functions	Codings adaptor between GAP1605 and Dupline® modules without standard connection plug	Active antenna used for radio controlled clock	Cable termination unit
Housing type	Handheld box	Glued plastic casing	H1 housing
Electrical specifications			
Features/Signal types	4 clip-on terminals for Dupline® modules. Includes a M12 plug for modules like G8911 1010	Input signal is 77.5 kHz	Removes distortion caused by reflection
Power supply		Powered by G3800 XXXX	No power needed
General specifications			
Degree of protection	IP20	IP40	IP20
Operating temperature	0°C to +50°C	0°C to +50°C	-20°C to +50°C
Storage temperature	-20°C to +60°C	-20°C to +60°C	-50°C to +85°C
References			
Adaptor	ADAPT 1605		
Antenna		ANT2	
Standard Dupline®			DT01
Hi-line Dupline®			DT02

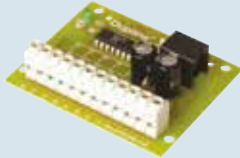

Fieldbuses - Agriculture

	Digital I/O modules		Converter	Tools
Types	GH3440 4412	GH6440 4412	GH3485 0000	GHTU8
				
Dimensions (mm)	77 x 72 x 70	80 x 77 x 50	77 x 72 x 70	145 x 90 x 28
Functions	I/O module for irrigation valve control	I/O module for irrigation valve control	Dupline® to Hi-Line converter	Dupline® test unit for monitoring and control of Dupline® channels. Used for Hi-line modules
Housing type	DIN-rail, H4	Fully molded housing for under ground installation	DIN-rail, H4	Handheld
Electrical specifications				
Number of channels	4	4	Adjusts automatically	Adjusts automatically
Features/Signal types	2 outputs for control of 3-wire 12 VDC latching valve, and 2 contact inputs	2 outputs for control of 3-wire 12 VDC latching valve, and 2 contact inputs	Converts the Dupline® signal to Hi-Line 28 VDC level for control of irrigation valves (see GH3440 4412 and GH6440 4412)	Digital, multiplexed BCD and 8-bit analogue signals
Power supply	Powered through Hi-Line signal (see GH34850000)	Powered through Hi-Line signal (see GH34850000)	724 = 20-30 VDC	Powered through the Dupline® network
General specifications				
Degree of protection	IP20	IP67	IP20	IP40
Operating temperature	0°C to +50°C	0°C to +50°C	0°C to +50°C	0°C to +50°C
Storage temperature	-50°C to +85°C	-50°C to +85°C	-50°C to +85°C	-20°C to +85°C
Remarks				Options for latching digital signals and for reading multiplexed BCD values
References				
2 outputs and 2 inputs	GH3440 4412	GH6440 4412		
Converter			GH3485 0000	
Monitoring and control unit				GHTU8

Fieldbuses - Elevator



	Input module	Output module	Input/output module
Types	G2120	G2130	G2140 4421
			
Dimensions (mm)	Open PCB 72.3 x 59	Open PCB 74 x 59	Open PCB 54 x 40
Functions	8 contact inputs for push buttons or transistors. LED indications for supply and carrier	8 outputs for control of floor indicators and lamps. LED indications for supply and carrier	2 push button inputs. 2 PNP-transistor outputs. LED indications for supply and carrier
Housing type	Snap locks or DIN-rail (vertical or horizontal)	Snap locks or DIN-rail (vertical or horizontal)	Snap locks or DIN-rail (vertical or horizontal)
Electrical specifications			
Number of channels	8	8	4
Features/Signal types	3-wire operation with DC-power on wire 3	3-wire operation with DC-power on wire 3	3-wire operation with DC-power on wire 3
Power supply	700 = 10 - 30 VDC	700 = 10 - 30 VDC	700 = 10 - 30 VDC
General specifications			
Operating temperature	-20°C to +50°C	-20°C to +50°C	-20°C to +50°C
References			
NPN	G2120 5501 700	G2130 5511 700	
PNP	G2120 5502 700	G2130 5521 700	G2140 4421 700

Fieldbuses - Elevator

	Input/output module	Master modules	
Types	G2140 55.0	G2196	G3496
			
Dimensions (mm)	Open PCB 74 x 59	Open PCB 86 x 54	77 x 72 x 70
Functions	4 push-button inputs 4 transistor outputs LED indications for supply and carrier	128 signals RS 485/RS 232 interface to control system LED indications for supply, carrier and RS485Tx	Plug & Play RS232/RS485 Interface with built-in protocols for specific PLC brands and Modbus
Housing type	Snap locks or DIN-rail (vertical or horizontal)	Snap locks or DIN-rail (vertical or horizontal)	DIN-rail, H4
Electrical specifications			
Number of channels	8	128 inputs and 128 outputs	Selectable
Features/Signal types	3-wire operation with DC-power on 3 wires	3-wire operation with DC-power on 3 wires	Possibility for 3-wire operation with DC-power on 3 wires
Power supply	700 = 10 - 30 VDC	700 = 20 - 30 VDC	700 = 20 - 30 VDC
General specifications			
Degree of protection			IP20
Operating temperature	-20°C to +50°C	-20°C to +60°C	0°C to +50°C
Storage temperature			-50°C to +85°C
Remarks			Built-in protocol for specific PLC brands for easy interfacing
References			
NPN	G2140 5510 700		
PNP	G2140 5520 700		
Omron			G3496 0004 700
Modbus RTU Slave		G2196 0005 700	
Allen-Bradley			G3496 0006 700
Matsushita			G3496 0009 700





Monitoring relays

Earth Leakage

Types	DEA71	DEB71
		
Dimensions HxWxD (mm) DIN-rail housing	81 x 35.5 x 67.2 [Mini-D]	81 x 35.5 x 67.2 [Mini-D]
Function	Modular residual current monitoring relay, fixed I Δ n setting, warning output @60% I Δ n, Alarm @80% I Δ n, no delay. Operates with CTG series core balance transformers	Modular residual current monitoring relay, adjustable I Δ n setting, warning output @60% I Δ n, Alarm @80% I Δ n, leakage level LED bar, adjustable delay. Operates with CTG series core balance transformers
Input specifications		
Measuring range I Δ n	30 mA 300 mA	30 mA to 5 A 300 mA to 30 A
Output specifications		
Type	2 x SPDT relay	2 x SPDT relay
Max. load AC1	5 A / 250 VAC	5 A / 250 VAC
Max. load DC12	5 A / 24 VDC	5 A / 24 VDC
Electrical life	>1 x 10 ⁵ operations	>1 x 10 ⁵ operations
General specifications		
Power supply	24 VAC to 240 VAC	24 VAC to 240 VAC
Approvals/Marks	CE - cULus	CE - cULus
References		
	DEA71DM24A003	DEB71DM24A5
	DEA71DM24A030	DEB71DM24A30





Monitoring relays

Current relays

Types	DIA 01 PIA 01	DIA 02	EIS H	DIA 53
				
Dimensions HxWxD (mm) DIN-rail housing Plug-in housing	80 x 22.5 x 99.5 [D] 80 x 36 x 94 [P]	80 x 22.5 x 99.5	56 x 22.5 x 49	81 x 17.5 x 67.2 [Mini-D]
Function	Over current monitoring relay. 1-phase AC / DC. Direct input or on CT 5 A. Setpoint adjustable. Hysteresis adjustable.	Load ON/OFF monitoring relay. 1-phase AC / DC. Direct input or on CT 5 A. Setpoint adjustable.	Load ON/OFF sensor. 1-phase AC Direct input and solid state output.	Over current monitoring relay. 1-phase AC. Setpoint adjustable. 2-wire connection. Reaction time < 50 ms for F versions. 12 mm hole for insulated current carrying wire.
Input specifications				
Measuring range	0.5 - 5 AAC/DC	2 mA - 5 AAC/DC	200 mA - 60 AAC [024] 400 mA - 60 AAC [230]	2 - 20 AAC [20 A] 5 - 50 AAC [50 A] 10 - 100 AAC [100 A]
Output specifications				
Type	1 x SPDT relay	1 x SPDT relay	Static output	Static output
Max. load AC1	8 A / 250 VAC	8 A / 250 VAC	1 A [024] 0.5 A [230]	
Max. load DC12	5 A / 24 VDC	5 A / 24 VDC	1 A [024] 0.5 A [230]	100 mA
Electrical life	>1 x 10 ⁵ operations	>1 x 10 ⁵ operations		
General specifications				
Power supply	24-48 VAC/DC [D48] 115 / 230 VAC [B23]	24-48 VAC/DC [D48] 115 / 230 VAC [B23]	Powered by the measured current	40 VDC max. Powered by the measured current
Approvals/Marks	CE - UL - CSA	CE - cULus	CE - cURus - CSA	CE - UL - CSA
References				
	DIA01C D48 5A	DIA02C D48 5A	EISH 200MA 024	DIA53S 724 20A
	PIA01C D48 5A	DIA02C B23 5A	EISH 400MA 230	DIA53S 724 50A
	DIA01C B23 5A			DIA53S 724 100A
	PIA01C B23 5A			DIA53S 724 20A F
				DIA53S 724 50A F
				DIA53S 724 100A F

Monitoring relays

Current relays

Types	DIB 01 PIB 01	DIB 71	DIB 02 PIB 02	DIC 01 PIC 01
				
Dimensions HxWxD (mm)				
DIN-rail housing	80 x 22.5 x 99.5 [D]	81 x 35.5 x 67.2 [Mini-D]	80 x 22.5 x 99.5 [D]	80 x 45 x 99.5 [D]
Plug-in housing	80 x 36 x 94 [P]		80 x 36 x 94 [P]	80 x 36 x 94 [P]
Function	Over or under current monitoring relay. 1-phase AC / DC TRMS. Direct input or on CT 5 A. Setpoint adjustable. Hysteresis adjustable. Delay time adjustable. 12 mm hole for insulated current carrying wire [100 A]	Over or under current monitoring relay. 1-phase AC/DC TRMS. Direct input or on CT 5 A. Setpoint adjustable. Hysteresis adjustable. Delay time adjustable.	Over or under current monitoring relay. 1-phase AC/DC TRMS. Input on shunt or CT MI / MP. Setpoint adjustable. Hysteresis adjustable. Delay time adjustable.	Process signal monitoring relay. 1-phase AC/DC TRMS. Direct input, CT A82 or CT MI / MP. 2 setpoints separately adjustable. Hysteresis adjustable. 2 delay times separately adjustable.

Input specifications

Measuring range	0.1 - 5 mAAC/DC [5 MA] 1 - 50 mAAC/DC [50 MA] 10-500 mAAC/DC [500 MA] 0.1-5 AAC/DC [5 A] 1-10 AAC/DC [10 A] 2-100 AAC [100 A]	0.1 - 5 mAAC/DC [5 MA] 1 - 50 mAAC/DC [50 MA] 10 - 500 mAAC/DC [500 MA] 0.1 - 5 AAC/DC [5 A]	6 - 150 mVAC/DC 0.4 - 4 V _P	0.5 - 20 mAAC/DC 0.1 - 10 VAC/DC 0.4 - 4 V _P
-----------------	--	---	---	---

Output specifications

Type	1 x SPDT relay	1 x SPDT relay	1 x SPDT relay	1 x SPDT relay [P] 2 x SPDT relays [D]
Max. load AC1	8 A / 250 VAC	5 A / 250 VAC	8 A / 250 VAC	8 A / 250 VAC
Max. load DC12	5 A / 24 VDC	5 A / 24 VDC	5 A / 24 VDC	5 A / 24 VDC
Electrical life	>1 x 10 ⁵ operations	>1 x 10 ⁵ operations	>1 x 10 ⁵ operations	>1 x 10 ⁵ operations

General specifications

Power supply	24-48 VAC/DC [D48] 115 / 230 VAC [B23] 24 VDC / 24-240 VAC [M24]	24 / 48 VAC [B48] 115 / 230 VAC [B23]	24 - 48 VAC/DC [D48] 115 / 230 VAC [B23]	24 - 48 VAC/DC [D48] 115 / 230 VAC [B23]
Approvals/Marks	CE - cULus - CCC	CE - UL - CSA	CE - cULus	CE - UL - CSA

References

DIB01C... 5MA	DIB71C B48 5MA	DIB02C D48 150MV	DIC01D D48 AV0
DIB01C... 50MA	DIB71C B48 50MA	PIB02C D48 150MV	PIC01C D48 AV0
DIB01C... 500MA	DIB71C B48 500MA	DIB02C B23 150MV	DIC01D B23 AV0
DIB01C... 5A	DIB71C B48 5A	PIB02C B23 150MV	PIC01C B23 AV0
DIB01C... 10A	DIB71C B23 5MA		
DIB01C M24 100A	DIB71C B23 50MA		
PIB01C... 5MA	DIB71C B23 500MA		
PIB01C... 50MA	DIB71C B23 5A		
PIB01C... 500MA			
PIB01C... 5A			
PIB01C... 10A			

... = insert code for Power Supply

Monitoring relays

Voltage relays

Types

DUA 01
PUA 01

DUA 52

DUA 55



Dimensions HxWxD (mm)
DIN-rail housing
Plug-in housing

80 x 22.5 x 99.5 [D]
80 x 36 x 94 [P]

81 x 17.5 x 67.2 [Mini-D]

81 x 17.5 x 67.2 [Mini-D]

Function

Over current and voltage monitoring relay.
1-phase AC/DC or CT MI / MP. Setpoint
adjustable. Hysteresis adjustable.

Under voltage monitoring relay for DC
battery.
Setpoint adjustable.
Hysteresis adjustable.
Measures its own power supply.

Over and under voltage monitoring relay.
1-phase (measures its own power supply)
AC TRMS.

Input specifications

Measuring range	2 - 500 VAC/DC 0.4 - 4 V _P	8 - 28 VDC [724] 38 - 58 VDC [748]	208 / 220 / 230 / 240 VAC
-----------------	--	---------------------------------------	---------------------------

Output specifications

Type	1 x SPDT relay	1 x SPDT relay	1 x SPDT relay
Max. load AC1	8 A / 250 VAC	5 A / 250 VAC	5 A / 250 VAC
Max. load DC12	5 A / 24 VDC	5 A / 24 VDC	5 A / 24 VDC
Electrical life	>1 x 10 ⁵ operations	>1 x 10 ⁵ operations	>1 x 10 ⁵ operations

General specifications

Power supply	24 - 48 VAC/DC [D48] 115 / 230 VAC [B23]	8 - 28 VDC [724] 38 - 58 VDC [748]	208 - 480 VAC
Approvals/Marks	CE - UL - CSA	CE - UL - CSA	CE - UL - CSA - CCC

References

DUA01C D48 500V

DUA52 C724

DUA55 CM44

PUA01C D48 500V



DUA52 C748

DUA01C B23 500V

PUA01C B23 500V

Monitoring relays

Voltage relays

Types	DUB 01 PUB 01	DUB 71	DUB 72
			
Dimensions HxWxD (mm)			
DIN-rail housing	80 x 22.5 x 99.5 [D]	81 x 35.5 x 67.2 [Mini-D]	90 x 35.8 x 63.2 [Mini-D]
Plug-in housing	80 x 36 x 94 [P]		
Function	Over or under voltage monitoring relay. 1-phase AC/DC TRMS. Setpoint adjustable. Hysteresis adjustable. Delay time adjustable.	Over or under voltage monitoring relay. 1-phase AC/DC TRMS. Setpoint adjustable. Hysteresis adjustable. Delay time adjustable.	Double under voltage monitoring relay. 24 VDC. 2 adjustable setpoints + hysteresis. 2 independent relay outputs.
Input specifications			
Measuring range	0.1 - 10 VAC/DC [10 V] 2-500 VAC/DC [500 V]	0.1 - 10 VAC/DC [10 V] 2-500 VAC/DC [500 V]	16 - 30 VDC
Output specifications			
Type	1 x SPDT relay	1 x SPDT relay	1 x SPST 3 A 1 x SPST 20 A
Max. load AC1	8 A / 250 VAC	5 A / 250 VAC	
Max. load DC12	5 A / 24 VDC	5 A / 24 VDC	
Electrical life	>1 x 10 ⁵ operations	>1 x 10 ⁵ operations	>1 x 10 ⁵ operations
General specifications			
Power supply	24-48 VAC/DC [D48] 115 / 230 VAC [B23]	24/48 VAC [B48] 115 / 230 VAC [B23]	24 VDC
Approvals/Marks	CE - cULus - CCC	CE - UL - CSA	CE- cULus - ISA Class I Div 2
References			
	DUB01C D48 10V	DUB71C B48 10V	DUB72D724EX
	DUB01C D48 500V	DUB71C B48 500V	
	PUB01C D48 10V	DUB71C B23 10V	
	PUB01C D48 500V	DUB71C B23 500V	
	DUB01C B23 10V		
	DUB01C B23 500V		
	PUB01C B23 10V		
	PUB01C B23 500V		

Monitoring relays

Voltage relays

Types	DUB 02 PUB 02	DUB 03 PUB 03	DUC 01 PUC 01
-------	------------------	------------------	------------------



Dimensions HxWxD (mm)			
DIN-rail housing	80 x 22.5 x 99.5 [D]	80 x 22.5 x 99.5 [D]	80 x 45 x 99.5 [D]
Plug-in housing	80 x 36 x 94 [P]	80 x 36 x 94 [P]	80 x 36 x 94 [P]

Function	Over and under voltage monitoring relay. 1-phase (measures its own power supply) AC TRMS. Over and under voltage setpoints separately adjustable. Hysteresis adjustable. Delay time adjustable (ON/OFF).	Over or under voltage monitoring relay. 1-phase (measures its own power supply) AC/DC TRMS. Setpoint adjustable. Hysteresis adjustable. Delay time adjustable.	Over and under voltage monitoring relay. 1-phase AC/DC TRMS. 2 setpoints separately adjustable. Hysteresis adjustable. 2 delay functions separately adjustable.
----------	--	---	---

Input specifications

Measuring range	24/115/230 VAC	24/48/115/240 VAC/DC	2 - 500 VAC/DC [500 V]
-----------------	----------------	----------------------	------------------------

Output specifications

Type	1 x SPDT relay	1 x SPDT relay [P]	1 x SPDT relay [C] 2 x SPDT relay [D]
Max. load AC1	8 A / 250 VAC	8 A / 250 VAC	8 A / 250 VAC
Max. load DC12	5 A / 24 VDC	5 A / 24 VDC	5 A / 24 VDC
Electrical life	>1 x 10 ⁵ operations	>1 x 10 ⁵ operations	>1 x 10 ⁵ operations

General specifications





Power supply	24/115/230 VAC	12 - 240 VAC/DC	24 - 48 VAC/DC [D48] 115 / 230 VAC [B23]
Approvals/Marks	CE - cULus	CE - cULus	CE - UL - CSA

References

	DUB02C T23	DUB03C W24	DUC01D D48 500V
	PUB02C T23	PUB03C W24	PUC01C D48 500V
			DUC01D B23 500V
			PUC01C B23 500V





Monitoring relays

3-phase voltage relays

Types	DPA 01 PPA 01	DPA 51 DPA 71	DPA52	DPA 03 PPA 03
				
Dimensions HxWxD (mm) DIN-rail housing	80 x 22.5 x 99.5 [D]	81 x 17.5 x 67.2 [Mini-D] 81 x 35.5 x 67.2 [Mini-D]	81 x 17.5 x 67.2 [Mini-D]	80 x 22.5 x 99.5 [D]
Plug-in housing	80 x 36 x 94 [P]			80 x 36 x 94 [P]
Function	Phase sequence, total and partial phase loss monitoring relay. 3-phase AC (measures its own power supply). Regenerated voltage detection.	Phase sequence, total and partial phase loss monitoring relay. 3-phase AC (measures its own power supply). Regenerated voltage detection.	Phase sequence, total and partial phase loss monitoring relay. 3-phase AC TRMS (measures its own power supply), switching power supply. Regenerated voltage detection.	Under voltage, phase sequence, total and partial phase loss monitoring relay. 3-phase AC TRMS (measures its own power supply). Regenerated voltage detection.
Input specifications				
Measuring range	208 - 240 VAC [M23] 208 - 415 VAC [P] [M44] 208 - 480 VAC [D] [M44] 380 - 415 VAC [P] [M48] 380 - 480 VAC [D] [M48] 380 - 600 VAC [M60] 600 - 690 VAC [M69]	208 - 240 VAC [M23] 208 - 480 VAC [M44] 380 - 480 VAC [M48]	208 - 480 VAC	208 - 240 VAC [M23] 380 - 415 VAC [P] [M48] 380 - 480 VAC [D] [M48] 600 - 690 VAC [M69]
Output specifications				
Type	1 x SPDT relay [C] 1 x DPDT relay [D]	1 x SPDT relay [C] 1 x DPDT relay [D]	1 x SPDT relay	1 x SPDT relay
Max. load AC1	8 A / 250 VAC	5 A / 250 VAC	5 A / 250 VAC	8 A / 250 VAC
Max. load DC12	5 A / 24 VDC	5 A / 24 VDC	5 A / 24 VDC	5 A / 24 VDC
Electrical life	>1 x 10 ⁵ operations	>1 x 10 ⁵ operations	>1 x 10 ⁵ operations	>1 x 10 ⁵ operations
General specifications				
Power supply	208 - 240 VAC [M23] 208 - 415 VAC [P] [M44] 208 - 480 VAC [D] [M44] 380 - 415 VAC [P] [M48] 380 - 480 VAC [D] [M48] 380 - 600 VAC [M60] 600 - 690 VAC [M69]	208 - 240 VAC [M23] 208 - 480 VAC [M44] 380 - 480 VAC [M48]	208 - 480 VAC	208 - 240 VAC [M23] 380 - 415 VAC [P] [M48] 380 - 480 VAC [D] [M48] 600 - 690 VAC [M69]
Approvals/Marks	CE - UL - CSA	CE - UL - CSA	CE - cULus - CCC	CE - UL - CSA
References				
	DPA01D M23	DPA51C M44	DPA52CM44	DPA03C M23
	PPA01D M23	DPA71D M23		PPA03C M23
	DPA01C M44	DPA71D M48		DPA03C M48
	PPA01C M44			PPA03C M48
	DPA01D M48			DPA03C M69
	PPA01D M48			
	DPA01C M60			
	DPA01C M69			





Monitoring relays

3-phase voltage relays

Types	DPA 53	DPA 55	DPB 51	DPB52
				
Dimensions HxWxD (mm) DIN-rail housing	81 x 17.5 x 67.2 [Mini-D]	81 x 17.5 x 67.2 [Mini-D]	90 x 17.5 x 67.2 [Mini-D]	81 x 17.5 x 67.2 [Mini-D]
Function	Under voltage, phase sequence, total and partial phase loss monitoring relay. 3-phase AC TRMS (measures its own power supply). Regenerated voltage detection.	Over and under voltage, phase sequence, total and partial phase loss monitoring relay. 3-phase (measures its own power supply) AC TRMS. Two tolerance voltage windows. Regenerated voltage detection.	Over and under voltage, phase sequence, phase loss, neutral loss monitoring relay. 3-phase+N AC TRMS (measures its own power supply). Regenerated voltage detection 2 setpoints separately adjustable. Delay time adjustable.	Over and under voltage, phase sequence, phase loss monitoring 3-phase (measures its own power supply), switching power supply. Regenerated voltage detection. 2 setpoints separately adjustable. Delay time adjustable.
Input specifications				
Measuring range	208 - 240 VAC [M23] 380 - 480 VAC [M48]	208 - 480 VAC	208 - 480 VAC	208 - 480 VAC
Output specifications				
Type	1 x SPDT relay	1 x SPDT relay	1 x SPDT relay	1 x SPDT relay
Max. load AC1	5 A / 250 VAC	5 A / 250 VAC	5 A / 250 VAC	5 A / 250 VAC
Max. load DC12	5 A / 24 VDC	5 A / 24 VDC	5 A / 24 VDC	5 A / 24 VDC
Electrical life	>1 x 10 ⁵ operations	>1 x 10 ⁵ operations	>1 x 10 ⁵ operations	>1 x 10 ⁵ operations
General specifications				
Power supply	208 - 240 VAC [M23] 380 - 480 VAC [M48]	208 - 480 VAC	208 - 480 VAC	208 - 480 VAC
Approvals/Marks	CE - UL - CSA	CE - UL - CSA - CCC	CE - UL - CSA	CE - cULus - CCC
References				
	DPA53C M23 DPA53C M48	DPA55C M44	DPB51C M44	DPB52CM44

Monitoring relays

3-phase voltage relays

Types	DPB 01 PPB 01	DPB 02 PPB 02	DPC 01 PPC 01	DPC 71
				
Dimensions (mm) HxWxD	80 x 22.5 x 99.5 [D] 80 x 36 x 94 [P]	80 x 22.5 x 99.5 [D] 80 x 36 x 94 [P]	80 x 45 x 99.5 [D] 80 x 36 x 94 [P]	81 x 35.5 x 67.2 [D]
DIN-rail housing				
Plug-in housing				
Function	Over and under voltage, phase sequence, phase loss. 3-phase+N AC TRMS (measures its own power supply). N versions without phase sequence detection. Wide input voltage range, 50 Hz - 400 Hz [M44] 2 setpoints separately adjustable. Delay time adjustable.	Asymmetry, phase sequence, phase loss monitoring relay. 3-phase +N AC TRMS (measures its own power supply). Wide input voltage range, 50 Hz - 400 Hz [M44] Adjustable asymmetry. Delay time adjustable.	Over and under voltage, asymmetry and tolerance, phase sequence, phase loss monitoring relay. 3-phase+N AC TRMS (measures its own power supply), 50 Hz - 400 Hz mains. Setpoint separately adjustable by function.	Over and under voltage, asymmetry and tolerance, phase sequence, total and partial phase loss monitoring relay. 3-phase+N AC TRMS (measures its own power supply). Setpoints separately adjustable by function.

Input specifications

Measuring range	208 - 240 VAC [M23] 380 - 415 VAC [P] [M48] 380 - 480 VAC [D] [M48] 208 - 480 VAC [M44]	208 - 240 VAC [M23] 380 - 415 VAC [P] [M48] 380 - 480 VAC [D] [M48] 208 - 480 VAC [M44]	208 - 240 VAC [M23] 380 - 415 VAC [P] [M48] 380 - 480 VAC [D] [M48] 600 - 690 VAC [M69] Frequency 50 - 60 Hz 100 - 115 VAC [M11 400Hz] 208 - 240 VAC [M23 400Hz] 380 - 415 VAC [M48 400Hz] 440 - 480 VAC [M49 400Hz] 600 - 690 VAC [M69 400Hz] 208 - 690 VAC [M44] Frequency 50 - 400 Hz	208 - 240 VAC [M23] 380 - 480 VAC [M48]
-----------------	--	--	---	--

Output specifications

Type	1 x SPDT relay	1 x SPDT relay	2 x SPDT relays	2 x SPDT relays
Max. load AC1	8 A / 250 VAC	8 A / 250 VAC	8 A / 250 VAC	5 A / 250 VAC
Max. load DC12	5 A / 24 VDC	5 A / 24 VDC	5 A / 24 VDC	5 A / 24 VDC
Electrical life	>1 x 10 ⁵ operations	>1 x 10 ⁵ operations	>1 x 10 ⁵ operations	>1 x 10 ⁵ operations

General specifications

Power supply	208 - 240 VAC [M23] 380 - 415 VAC [P] [M48] 380 - 480 VAC [D] [M48] [W] 208 - 480 VAC [M44]	208 - 240 VAC [M23] 380 - 415 VAC [P] [M48] 380 - 480 VAC [D] [M48] [W] 208 - 480 VAC [M44]	100 - 115 VAC [M11] 208 - 240 VAC [M23] 380 - 415 VAC [P] [M48] 380 - 480 VAC [D] [M48] 440 - 480 VAC [M49] 600 - 690 VAC [M69] 208 - 690 VAC [M44]	208 - 240 VAC [M23] 380 - 415 VAC [P] [M48] 380 - 480 VAC [D] [M48]
Approvals/Marks	CE - cULus - CCC	CE - cULus - CCC	CE - cULus - CCC - RINA	CE - UL - CSA

References

DPB01C M23	DPB02C M23	DPC01D M23	DPC71D M23
PPB01C M23	PPB02C M23	PPC01D M23	DPC71D M48
DPB01C M23 N	DPB02C M44	DPC01D M44	
PPB01C M23 N	PPB02C M44	DPC01D M48	
DPB01C M44	DPB02C M48	PPC01D M48	
PPB01C M44	PPB02C M48	DPC01D M69	
DPB01C M48		DPC01D M11 400HZ	
PPB01C M48		DPC01D M23 400HZ	
DPB01C M48 W4		DPC01D M48 400HZ	
PPB01C M48 W4		DPC01D M49 400HZ	
DPB01C M48 N		DPC01D M69 400HZ	
PPB01C M48 N			
DPB01C M48 N W4			
PPB01C M48 N W4			

Monitoring relays

3-phase multifunction voltage relays

Interface protection relays

Types

DPC 02

DPD 02

PI-DIN



Dimensions HxWxD (mm)	80 x 45 x 99.5 [D]	80 x 22.5 x 99.5	90 x 71.6 x 66.3
Description	Over and under voltage, over and under frequency, phase sequence, phase loss monitoring relay. 3-phase+N AC TRMS (measures its own power supply). Setpoints separately adjustable. Separately adjustable delay times. Adjustable frequency range.	Over and under voltage, over and under frequency, asymmetry detection, phase loss and phase sequence monitoring relay. NFC communication 3-phase / 3-phase+N AC TRMS (measures its own power supply). Digital settings, setpoints separately adjustable. Separately adjustable delay times. Adjustable frequency range.	1- or 3-phase systems monitoring relay interface protection.

Measuring input

Voltage range	208 - 240 VAC [M23] 380 - 415 VAC [M48] 440 - 480 VAC [M49] 600 - 690 VAC [M69] 208 - 690 VAC [M44]	208 VAC - 480 VAC	230 V _{LN} , 400 V _{LL}
Frequency range	50 / 60 Hz	50 - 400 Hz	47.5 to 51.5 Hz
Display			LCD, 2 lines 4 dgt, 1 line 8 dgt

Signal inputs

VDE-AR-N-4105			2 digitals
CEI 0-21			4 digitals

Output specifications

Type	2 x SPDT relays	2 x SPDT relays	2 x SPDT relays
Max. load AC1	8 A / 250 VAC	8 A / 250 VAC	8 A @ 250 VAC
Max. load DC12	5 A / 24 VDC	5 A / 24 VDC	5 A / 24 VDC
Electrical life	>1 x 10 ⁵ operations	>1 x 10 ⁵ operations	>1 x 10 ⁵ operations
Serial communication protocol			RS485
Protocol			Modbus RTU



General specifications

Power supply	208 - 240 VAC [M23] 308 - 415 VAC [M48] 440 - 480 VAC [M49] 600 - 690 VAC [M69] 208 - 690 VAC [M44]	208 VAC - 480 VAC	115..230 VCA -20% +15% (48..62 Hz) Option 24 VDC -20% +10%
Approvals/Marks	CE - cULus - CCC - RINA	CE - cULus - CCC - RINA	CE - VDE-AR-N4105:2018 - CEI-0-21 - ER-G98-Issue-1-Am-1 - ER-G99-Issue-1-Am-3 - Dansk Energi

References



	DPC02D M23	DPD02D M44	
	DPC02D M48	DPD02D M44B	
	DPC02D M44		
	DPC02D M49		
	DPC02D M69		
CEI 0-21 (AC aux power)			PIDIN0021HI4R2S1XX
CEI 0-21 (DC aux power)			PIDIN0021LI4R2S1XX
VDE-AR-N 4105:2018; CEI 0 - 21; ER G98 Issue 1 Am 1; ER G99 Issue 1 Am 3; Dansk Energi (AC aux power)			PIDIN0126HI2R2S1XX
VDE-AR-N 4105:2018; CEI 0 - 21; ER G98 Issue 1 Am 1; ER G99 Issue 1 Am 3; Dansk Energi (DC aux power)			PIDIN0126LI2R2S1XX

Monitoring relays

	Frequency relays		Cosφ relays
Types	DFB 01 PFB 01	DFC 01	DWA 01 PWA 01
			
Dimensions HxWxD (mm)			
DIN-rail housing	80 x 22.5 x 99.5 [D]	80 x 45 x 99.5 [D]	80 x 22.5 x 99.5 [D]
Plug-in housing	80 x 36 x 94 [P]		80 x 36 x 94 [P]
Function	Frequency monitoring relay. 1-phase AC (measures its own power supply). 2 setpoints separately adjustable. Delay time adjustable.	Frequency monitoring relay. 1-phase AC (measures its own power supply). 2 setpoints separately adjustable. 2 separately adjustable delay times. 2 separate relay outputs.	Cosφ monitoring relay. 1- or 3-phase AC (measures its own power supply). Direct input or through external CT. Power ON delay adjustable.
Input specifications			
Measuring range	50 / 60 Hz	50 / 60 Hz	cosφ: 0.1-0.99
Output specifications			
Type	1 x SPDT relay	2 x SPDT relay	1 x SPDT relay
Max. load AC1	8 A / 250 VAC	8 A / 250 VAC	8 A / 250 VAC
Max. load DC12	5 A / 24 VDC	5 A / 24 VDC	5 A / 24 VDC
Electrical life	>1 x 10 ⁵ operations	>1 x 10 ⁵ operations	>1 x 10 ⁵ operations
General specifications			
Power supply	24 - 240 VAC	24 - 48 VAC [B48] 115 - 230 VAC [B23]	208 - 240 VAC [M23] 380 - 415 VAC [P] [M48] 380 - 480 VAC [D] [M48]
Approvals/Marks	CE - UL - CSA	CE - UL - CSA	CE - UL - CSA
References			
	DFB01C M24	DFC01D B48	DWA01C M23 5A
	PFB01C M24	DFC01D B23	PWA01C M23 5A
			DWA01C M48 5A
			PWA01C M48 5A

Monitoring relays

Power and power factor relays

Types	DWB 01 PWB 01	DWB 02 PWB 02	DWB 03 PWB 03
			
Dimensions HxWxD (mm)	80 x 45 x 99.5 [D] 80 x 36 x 94 [P]	80 x 45 x 99.5 [D] 80 x 36 x 94 [P]	80 x 45 x 99.5 [D] 80 x 36 x 94 [P]
DIN-rail housing			
Plug-in housing			
Function	Power factor monitoring relay. 1- or 3-phase (measures its own power supply) AC TRMS. Direct input or through external CT. 2 separately adjustable setpoints. Delay time adjustable. Power ON delay adjustable.	Active power monitoring relay. 1- or 3-phase (measures its own power supply) AC TRMS. Direct input or through external CT. 2 separately adjustable setpoints. Delay time adjustable. Power ON delay adjustable.	Active power, with power direction, monitoring relay. 1- or 3-phase AC TRMS (measures its own power supply). Direct input or through external CT. 2 separately adjustable setpoints. Delay time adjustable. Power ON delay adjustable.

Input specifications

Measuring range	Power factor: 0.1 - 0.99	208 - 690 VAC 0.5 - 5 AAC 1 - 10 AAC 0.4 - 4 Vp	208 - 690 VAC 0.5 - 5 AAC 1 - 10 AAC 0.4 - 4 Vp
-----------------	--------------------------	--	--

Output specifications

Type	1 x SPDT relays	1 x SPDT relays	1 x SPDT relays
Max. load AC1	8 A / 250 VAC	8 A / 250 VAC	8 A / 250 VAC
Max. load DC12	5 A / 24 VDC	5 A / 24 VDC	5 A / 24 VDC
Electrical life	>1 x 10 ⁵ operations	>1 x 10 ⁵ operations	>1 x 10 ⁵ operations





General specifications

Power supply	208 - 240 VAC [M23] 380 - 415 VAC [P] [M48] 380 - 480 VAC [D] [M48] 600 - 690 VAC [M69]	208 - 240 VAC [M23] 380 - 415 VAC [P] [M48] 380 - 480 VAC [D] [M48] 600 - 690 VAC [M69]	208 - 240 VAC [M23] 380 - 415 VAC [P] [M48] 380 - 480 VAC [D] [M48] 600 - 690 VAC [M69]
Approvals/Marks	CE - UL - CSA	CE - UL - CSA	CE - UL - CSA

References

DWB01C M23 10A	DWB02C M23 10A	DWB03C M23 10A
PWB01C M23 10A	PWB02C M23 10A	PWB03C M23 10A
DWB01C M48 10A	DWB02C M48 10A	DWB03C M48 10A
PWB01C M48 10A	PWB02C M48 10A	PWB03C M48 10A
DWB01C M69 10A	DWB02C M69 10A	DWB03C M69 10A

Monitoring relays

	Motor thermistor relays			Pump alternating relays
Types	DTA 01 / PTA 01 DTA 02 / PTA 02	DTA 71 DTA 72	DTA 04	DLA 71 DLA 73
				
Dimensions HxWxD (mm)				
DIN-rail housing	80 x 22.5 x 99.5	81 x 35.5 x 67.2 [Mini-D]	80 x 22.5 x 99.5	81 x 35.5 x 67.2 [Mini-D]
Plug-in housing	80 x 36 x 94			
Function	Motor Thermistor relays. PTC insulated input. Automatic set-point. Short circuit detection. Latch, test and reset function [DTA02, PTA02].	Motor Thermistor relays. PTC insulated input. Automatic set-point. Short circuit and Open Circuit detection. Automatic Reset [DTA71] Auto or Manual reset, local or remote, test and ready for reset functions [DTA72].	Motor Thermistor relays. PTC insulated input. Automatic set-point. Short circuit and Open Circuit detection. Automatic or manual Reset, test, ready for reset functions.	Pump alternating relay. For 2 or 3 pumps. Differential or sequential mode. Automatic rotation of the pumps. Output relay managed by one independent input contact [DLA73].

Output specifications

Type	1 x SPDT relay or 1 x SPST relay	1 x SPDT relay [DTA71] 2 x SPDT relay [DTA72]	2 x SPST relays	2 x SPST relay [DLA71] [2P] 3 x SPST relay [DLA71] [3P] 3 x SPST relay [DLA73]
Max. load AC1	8 A / 250 VAC	8 A / 250 VAC	8 A / 250 VAC	5 A / 250 VAC
Max. load DC12	5 A / 24 VDC	5 A / 24 VDC	5 A / 24 VDC	5 A / 24 VDC
Electrical life	>1 x 10 ⁵ operations	>1 x 10 ⁵ operations	>1 x 10 ⁵ operations	>1 x 10 ⁵ operations

General specifications

Power supply	24 - 48 VAC/DC [D48] 115 VAC [115] 230 VAC [230]	24 - 240 VAC/DC	24 - 240 VAC/DC	24 / 48 VAC [B48] 115 / 230 VAC [B23]
Approvals/Marks	CE - UL - CSA	CE - cULus	CE - cULus	CE - UL - CSA

References

DTA01C D48	DTA71CM24	DTA04DM24	DLA71D B48 2P
DTA01C 115	DTA72DM24		DLA71T B48 3P
DTA01C 230			DLA71D B23 2P
DTA02C D48			DLA71T B23 3P
DTA02C 115			DLA73T B23 2P
DTA02C 230			DLA73T B48 2P
PTA01C D48			
PTA01C 115			
PTA01C 230			
PTA02C D48			
PTA02C 115			
PTA02C 230			

Timers

Delay on operate

Types	DAA 01 PAA 01	DAA 51 DAA 71	FAA 01 FAA 08
-------	------------------	------------------	------------------



Dimensions HxWxD (mm)	80 x 22.5 x 99.5 [D] 80 x 36 x 94 [P]	81 x 17.5 x 67.2 [Mini-D] 81 x 35.5 x 67.2 [Mini-D]	48 x 48 x 83.4
DIN-rail housing			
Plug-in housing			
Function	Delay on operate (manual start).	Delay on operate (automatic start).	Delay on operate. Symmetrical recycler. Interval. One shot.

Input specifications

Time range	0.1 s - 1 s 1 s - 10 s 6 s - 60 s 60 s - 600 s 0.1 h - 1 h 1 h - 10 h 10 h - 100 h	0.1 s - 1 s 1 s - 10 s 6 s - 60 s 60 s - 600 s 0.1 h - 1 h 1 h - 10 h 10 h - 100 h	Full scale 12 0.02 - 1.2 s 0.2 - 12 s 2 - 120 s 0.2 - 12 m 2 - 120 m 0.2 - 12 h 2 - 120 h	Full scale 30 0.05 - 3 s 0.5 - 30 s 5 - 300 s 0.5 - 30 m 5 - 300 m 0.5 - 30 h 5 - 300 h
------------	--	--	--	--

Output specifications

	1 x SPDT relay [C] 2 x SPDT relays [D]	1 x SPDT relay [C] 1 x DPDT relay [D]	1 x DPDT relay 11-pin [01] 8-pin [08]
Max. load AC1	8 A / 250 VAC	5 A / 250 VAC	5 A / 250 VAC
Max. load DC12	5 A / 24 VDC	5 A / 24 VDC	5 A / 24 VDC
Electrical life	>1 x 10 ⁵ operations	>1 x 10 ⁵ operations	>1 x 10 ⁵ operations



General specifications

Power supply	24 VDC / 24 - 240 VAC [C] 24 - 240 VAC/DC [D]	24 VDC / 24-240 VAC [CM24] 24-240 VAC/DC [DM24] 12-240 VAC/DC [DW24]	12-240 VAC/DC
Approvals/Marks	CE - UL - CSA	CE - UL - CSA - RINA [DAA51 only] - CCC [DAA51_B001 only]	CE - UL - CSA





References

DAA01C M24	DAA51C M24	FAA01D W24
PAA01C M24	DAA71D M24	FAA08D W24
DAA01D M24	DAA71D W24	
PAA01D M24		

Timers





	Delay on operate	Delay on release	
Types	HAA 08 HAA 14	DBA 02 PBA 02	DBA 52
			
Dimensions HxWxD (mm)			
DIN-rail housing		80 x 22.5 x 99.5 [D]	81 x 17.5 x 67.2 [Mini-D]
Plug-in housing	28 x 21.5 x 64	80 x 36 x 94 [P]	
Function	Delay on operate. Symmetrical recycler with ON or OFF first. Interval.	Delay on release.	Delay on release.
Input specifications			
Time range	0.1 s - 1 s 1 s - 10 s 6 s - 60 s 60 s - 600 s 0.1 h - 1 h 1 h - 10 h 10 h - 100 h	0.1 s - 1 s / 1 s - 10 s 6 s - 60 s / 60 s - 600 s 0.1 h - 1 h / 1 h - 10 h 10 h - 100 h	0.1 s - 1 s / 1 s - 10 s 6 s - 60 s / 60 s - 600 s 0.1 h - 1 h / 1 h - 10 h 10 h - 100 h
Output specifications			
	1 x 4PDT relay [Q] 1 x DPDT relay [D] 14-pin [14] 8-pin [08]	1 x SPDT relay	1 x SPDT relay
Max. load AC1	5 A / 250 VAC	8 A / 250 VAC	5 A / 250 VAC
Max. load DC12	5 A / 24 VDC	5 A / 24 VDC	5 A / 24 VDC
Electrical life	>1 x 10 ⁵ operations	>1 x 10 ⁵ operations	>1 x 10 ⁵ operations
General specifications			
Power supply	24-240 VAC/DC	24 VDC / 24-240 VAC	24 VDC / 24-240 VAC
Approvals/Marks	CE - UL - CSA	CE - UL - CSA	CE - UL - CSA
References			
	HAA14Q M24	DBA02C M24	DBA52C M24
	HAA08D M24	PBA02C M24	

Timers

	True delay on release		Recycler	
Types	D/PBB 01 D/PBB 02	DBB 51	DCB 01 PCB 01	DCB 51
				
Dimensions HxWxD (mm) DIN-rail housing Plug-in housing	80 x 22.5 x 99.5 [D] 80 x 36 x 94 [P]	81 x 17.5 x 67.2 [Mini-D]	80 x 22.5 x 99.5 [D] 80 x 36 x 94 [P]	81 x 17.5 x 67.2 [Mini-D]
Function	True delay on release.	True delay on release.	Asymmetrical recycler with ON and OFF time first. One shot. Two state delay on operate.	Asymmetrical recycler with ON or OFF first.
Input specifications				
Time range	D/PBB01: 0.1 s - 1 s / 1 s - 10 s 6 s - 60 s / 60 s - 600 s D/PBB02: 60 s - 600 s / 0.1 h - 1 h 1 h - 10 h	1 s - 10 s [10S] 6 s - 60 s [1M] 60 s - 600 s [10M]	0.1 - 1 s / 1 - 10 s 6 - 60 s / 60 s - 600 s 0.1 h 1 h / 1 h - 10 h 10 h - 100 h	0.1 - 1 s / 1 - 10 s 6 - 60 s / 60 s - 600 s 0.1 h 1 h / 1 h - 10 h 10 h - 100 h
Output specifications				
	1 x SPDT relay [C] 1 x DPDT relay [D]	1 x SPDT relay	1 x SPDT relay [C] 2 x SPDT relays [D]	1 x SPDT relay
Max. load AC1	8 A / 250 VAC	5 A / 250 VAC	8 A / 250 VAC	5 A / 250 VAC
Max. load DC12	5 A / 24 VDC	5 A / 24 VDC	5 A / 24 VDC	5 A / 24 VDC
Electrical life	>1 x 10 ⁵ operations	>1 x 10 ⁵ operations	>1 x 10 ⁵ operations	>1 x 10 ⁵ operations
General specifications				
Power supply	24-240 VAC/DC [M24] 12-24 VDC [724]	24 VDC / 24-240 VAC	24 VDC / 24-240 VAC [C] 24-240 VAC/DC [D]	24 VDC / 24-240 VAC
Approvals/Marks	CE - UL - CSA	CE - UL - CSA	CE - UL - CSA	CE - UL - CSA
References				
	DBB01C M24	DBB51C M24 10S	DCB01C M24	DCB51C M24
	PBB01C M24	DBB51C M24 1M	PCB01C M24	
	DBB01D M24	DBB51C M24 10M	DCB01D M24	
	PBB01D M24		PCB01D M24	
	DBB01C 724			
	PBB01C 724			
	DBB01D 724			
	PBB01D 724			
	DBB02C M24			
	PBB02C M24			
	DBB02D M24			
	PBB02D M24			

Timers

Multifunction

Types	DMB 01 PMB 01	DMB 51 DMB 71	FMB 01	DMC 01 PMC 01
				
Dimensions HxWxD (mm)				
DIN-rail housing	80 x 22.5 x 99.5 [D]	81 x 17.5 x 67.2 [Mini-D] 81 x 35.5 x 67.2 [Mini-D]		80 x 22.5 x 99.5 [D] 80 x 45 x 99.5 [D] 80 x 36 x 94 [P]
Plug-in housing	80 x 36 x 94 [P]		48 x 48 x 83.4	

Function	DMB 01 PMB 01	DMB 51 DMB 71	FMB 01	DMC 01 PMC 01
	Multifunction: <ul style="list-style-type: none"> • Delay on operate - manual start • Delay on release • Interval - manual start • Symmetrical recycler • Double interval • Interval on trigger open 	Multifunction: <ul style="list-style-type: none"> • Delay on operate - manual start • Delay on release • Interval - manual start • Symmetrical recycler • Double interval • Interval on trigger open 	Multifunction: (Trigger, Gate and Reset inputs) <ul style="list-style-type: none"> • Delay on operate - manual start • Delay on release • Interval - manual start • Symmetrical recycler • Double interval • Interval on trigger open 	Multifunction: <ul style="list-style-type: none"> • Delay on operate - manual start • Delay on operate - automatic and manual start • Delay on release • Interval - manual start • Interval - automatic and manual start • Interval - manual start with no time reset • Interval - automatic and manual start with no time reset

Input specifications

Time range	DMB 01 PMB 01	DMB 51 DMB 71	FMB 01	DMC 01 PMC 01
	0.1 s - 1 s / 1 s - 10 s 6 s - 60 s / 60 s - 600 s 0.1 h - 1 h / 1 h - 10 h 10 h - 100 h	0.1 s - 1 s / 1 s - 10 s 6 s - 60 s / 60 s - 600 s 0.1 h - 1 h / 1 h - 10 h 10 h - 100 h	Full scale: 12 0.02 - 1.2 s / 0.2 - 12 s 2 - 120 s / 0.2 - 12 m 2 - 120 m / 0.2 - 12 h 2 - 120 h Full scale: 30 0.05 - 3 s / 0.5 - 30 s 5 - 300 s / 0.5 - 30 m 5 - 300 m / 0.5 - 30 h 5 - 300 h	0.1 s - 1 s / 1 s - 10 s 6 s - 60 s / 60 s - 600 s 0.1 h - 1 h / 1 h - 10 h 10 h - 100 h

Output specifications

	DMB 01 PMB 01	DMB 51 DMB 71	FMB 01	DMC 01 PMC 01
	1 x SPDT relay [C] 1 x DPDT relay [D]	1 x SPDT relay [C] 1 x DPDT relay [D]	1 x DPDT relay	1 x SPDT relay [C] 2 x SPDT relay [D]
Max. load AC1	8 A / 250 VAC	5 A / 250 VAC	5 A / 250 VAC	8 A / 250 VAC
Max. load DC12	5 A / 24 VDC	5 A / 24 VDC	5 A / 24 VDC	5 A / 24 VDC
Electrical life	>1 x 10 ⁵ operations	>1 x 10 ⁵ operations	>1 x 10 ⁵ operations	>1 x 10 ⁵ operations

General specifications



	DMB 01 PMB 01	DMB 51 DMB 71	FMB 01	DMC 01 PMC 01
Power supply	24 VDC & 24-240 VAC [C] 24-240 VAC/DC [D]	24 VDC & 24-240 VAC [M24] 12-240 VAC/DC [W24]	12-240 VAC/DC	24 VDC [724] 24 / 48 VAC [B48] 115 / 230 VAC [B23] 24 VAC [024] 115 VAC [115] 230 VAC [230]
Approvals/Marks	CE - UL - CSA - RINA [DMB01 only]	CE - UL - CSA - RINA [DMB51 only] - CCC [DMB51_B006 only]	CE - UL - CSA	CE - UL - CSA

References

	DMB 01 PMB 01	DMB 51 DMB 71	FMB 01	DMC 01 PMC 01
	DMB01C M24	DMB51C M24	FMB01D W24	DMC01C xxx
	PMB01C M24	DMB51C W24		PMC01C yyy
	DMB01D M24	DMB71D M24		DMC01D xxx
	PMB01D M24	DMB71D W24		PMC01D yyy

xxx= 724, B23, B48
yyy= 724, 024, 115, 230

Timers

	Mini-E timers	Star delta	
Types	EAS EBS ECS	DAC 01/PAC 01	DAC 51
			
Dimensions HxWxD (mm)			
DIN-rail housing	56 x 22.5 x 49 [Mini-E] 56 x 22.5 x 44 [Mini-E] [F]	80 x 22.5 x 99.5 [D]	81 x 17.5 x 67.2 [Mini-D]
Plug-in housing		80 x 36 x 94 [P]	
Function	EAS - Delay on operate (automatic start). EBS - Interval (automatic start). ECS - Symmetrical recycler (ON/OFF automatic start) thyristor output. Screw or fast-ON connection. DIN-rail or chassis mounting	Star delta	Star delta
Input specifications			
Time range	[10S]: 0.5 s - 10 s [1M]: 0.1 m - 1 m [10M]: 1 m - 10 m	0.1 s - 1 s / 1 s - 10 s 6 s - 60 s / 60 s - 600 s	0.1 s - 1 s / 1 s - 10 s 6 s - 60 s / 60 s - 600 s
Star to delta relay (neutral centre position)		50 - 130 ms between star to delta position	50 - 130 ms between star to delta position
Output specifications			
	Static output 500 mA, 700 mA [F]	1 x SPDT relay (with neutral centre position)	1 x SPDT relay (with neutral centre position)
Max. load AC1		8 A / 250 VAC	5 A / 250 VAC
Max. load DC12		5 A / 24 VDC	5 A / 24 VDC
Electrical life		>1 x 10 ⁵ operations	>1 x 10 ⁵ operations
General specifications			
Power supply	24-230 VAC/DC [EAS] 24-230 VAC [EBS], [ECS]	24-240 VAC/DC [M24] 380-415 VAC [M40]	24-240 VAC/DC
Approvals/Marks	CE - UL - CSA	CE - UL - CSA	CE - UL - CSA
References			
	EAS S M23 ...	DAC01C M24	DAC51C M24
	EAS S M23 ... F	PAC01C M24	
	EBS S M23 ...	DAC01C M40	
	EBS S M23 ... F	PAC01C M40	
	ECS S M23 A ...		
	ECS S M23 B ...		
	ECS S M23 A ... F		
	ECS S M23 B ... F		
	... = insert code for Time Range		

По вопросам продаж и поддержки обращайтесь:

Алматы (7273)495-231	Казань (843)206-01-48	Новокузнецк (3843)20-46-81	Смоленск (4812)29-41-54
Архангельск (8182)63-90-72	Калининград (4012)72-03-81	Новосибирск (383)227-86-73	Сочи (862)225-72-31
Астрахань (8512)99-46-04	Калуга (4842)92-23-67	Омск (3812)21-46-40	Ставрополь (8652)20-65-13
Барнаул (3852)73-04-60	Кемерово (3842)65-04-62	Орел (4862)44-53-42	Сургут (3462)77-98-35
Белгород (4722)40-23-64	Киров (8332)68-02-04	Оренбург (3532)37-68-04	Тверь (4822)63-31-35
Брянск (4832)59-03-52	Краснодар (861)203-40-90	Пенза (8412)22-31-16	Томск (3822)98-41-53
Владивосток (423)249-28-31	Красноярск (391)204-63-61	Пермь (342)205-81-47	Тула (4872)74-02-29
Волгоград (844)278-03-48	Курск (4712)77-13-04	Ростов-на-Дону (863)308-18-15	Тюмень (3452)66-21-18
Вологда (8172)26-41-59	Липецк (4742)52-20-81	Рязань (4912)46-61-64	Ульяновск (8422)24-23-59
Воронеж (473)204-51-73	Магнитогорск (3519)55-03-13	Самара (846)206-03-16	Уфа (347)229-48-12
Екатеринбург (343)384-55-89	Москва (495)268-04-70	Санкт-Петербург (812)309-46-40	Хабаровск (4212)92-98-04
Иваново (4932)77-34-06	Мурманск (8152)59-64-93	Саратов (845)249-38-78	Челябинск (351)202-03-61
Ижевск (3412)26-03-58	Набережные Челны (8552)20-53-41	Севастополь (8692)22-31-93	Череповец (8202)49-02-64
Иркутск (395)279-98-46	Нижний Новгород (831)429-08-12	Симферополь (3652)67-13-56	Ярославль (4852)69-52-93
Россия (495)268-04-70	Киргизия (996)312-96-26-47	Казахстан (7172)727-132	